

Features

- Frequency Range 700-1000MHz
- Low conversion loss 7dB (typical)
- High IP3: +26 dBm(typical)
- LO drive:+17dBm
- Industry standard surface mount package:S07
- Low cost

Description

The MXB-1003-17 is a double double-balanced mixer designed for high frequency low conversion loss both up and down transceiver applications. Construction uses an industry standard surface mount package.

Specifications

Frequency Range: RF/LO 700-1000MHz,IF DC-250MHz

Test Conditions: RF input -10dBm /LO +17dBm/IF 30MHz/Temp.+25°C

Parameter	Min.	Typ.	Max.	Notes
Conversion Loss(dB)				
700-1000 MHz		7	8.5	1.Specifications and information are subject to change without notice. 2.IIP3 is typical, not guaranteed 3.Package information see Package Page
L-R Isolation(dB)				
700-1000 MHz	20	32		
L-I Isolation(dB)				
700-1000 MHz	20	40		
IIP3(dBm)		26		
Input 1dB compression point(dBm)		13		

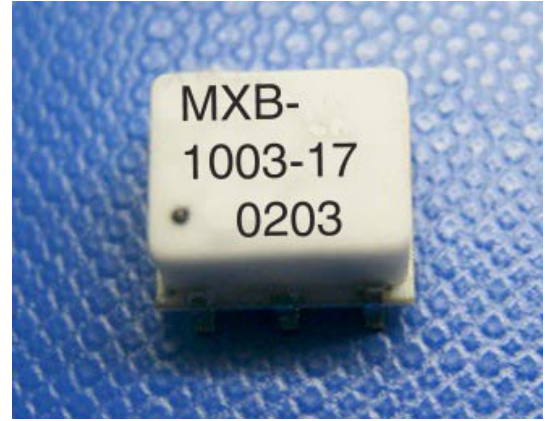

Absolute Maximum Ratings

Parameter	Max
RF input power	+23dBm
Operating Temp.(°C)	-50°C~+80°C
Storage Temp.(°C)	-65°C~+100°C
Reflow Temp (°C)	+240°C

Schematic

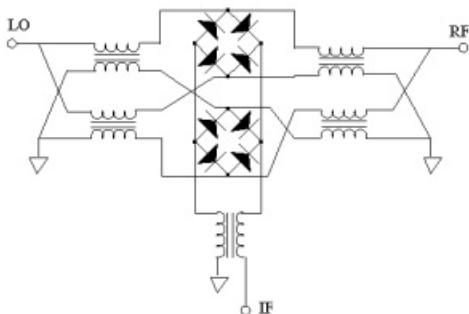

Pin functions

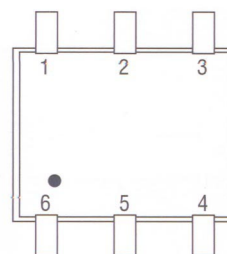

LO	Pin1
RF	Pin3
IF	Pin4
GND	Pin2,5,6