

Rev	AWO #	Description	Date	Appr
-		RELEASED	3/24/09	

APPROVED: _____
 DATE: _____

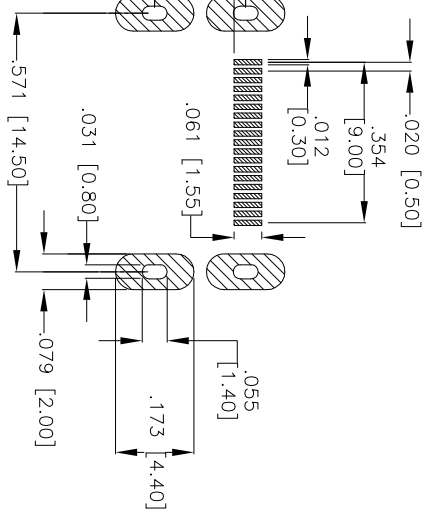
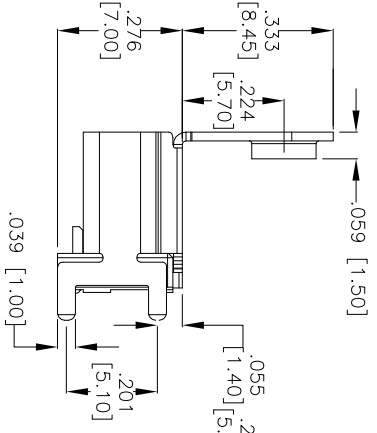
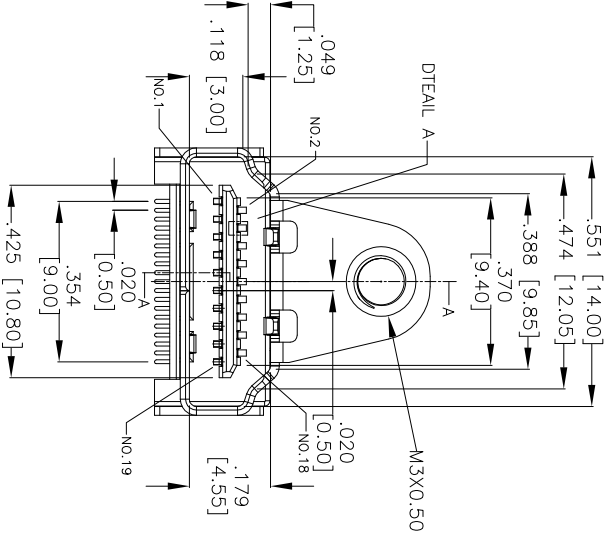
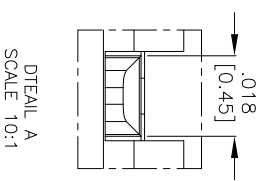
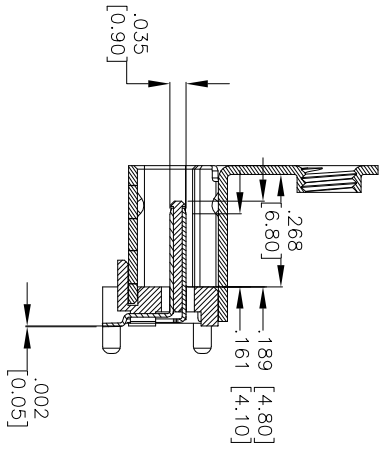
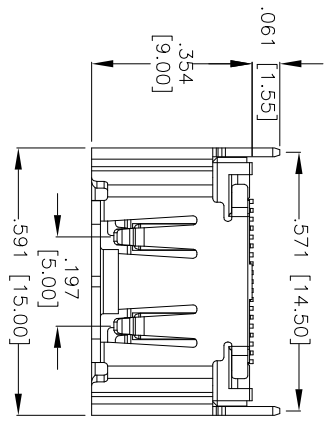

RECOMMENDED PCB LAYOUT

SPECIFICATIONS:

- Material: Housing: HI-temp thermoplastic, UL 94V-0
- Housing color: Black
- Contact: Phosphor Bronze
- Shield: Brass
- Plating: Gold flash over Nickel underplate on contact area, Tin over Copper underplate on tails.

Electrical:

- Voltage rating: 40V
- Current rating: 0.5A
- Dielectric strength: 500VAC for 1 minute min.
- Insulation resistance: 100 Megohm min.
- Contact resistance: 30 mohms max.
- Environmental: Lead free, RoHS Compliant
- Recommended soldering temp: 260°C for 5 seconds.



ADAM TECH

909 Rahway Avenue, Union, NJ 07083
 Phone: 908-687-5000 Fax: 908-687-5710

TITLE: **HDMI CONNECTOR WITH MOUNTING FLANGE**
 TRUE SMT TYPE

UNLESS OTHERWISE SPECIFIED ALL DIMENSIONS ARE INCHES [MM]	
TOLERANCES: EXCEPT AS NOTED	HOLDS
.X ± .10	ØX ± .10
.XX ± .020	ØXX ± .015
.XXX ± .015	ØXXX ± .010
APPROVALS:	DATE
DRAWN: DY	3/24/09
CHECKED:	
APPROVED:	

SIZE: X	PART NO.: HDMI-S-V-TSMT-MF	REV.:
REF: S00009C	SCALE: NTS	SHEET 1 OF 1