



LDC25W Series– DC to DC

DC to DC Switch Mode Constant Current and Constant Voltage LED Drivers, Black Magic Thermal Advantage™ Plastic Housing

Electrical Specifications

Input Voltage Range:	12-24VDC, 18Vdc Nom. ± 6Vdc
Inrush Current:	<15 Amps max @ 12V, cold start 25°C
Input Current:	2.6 A @ 12Vdc, 1.6 A @ 18Vdc, max load
Maximum Power:	25W
Current Regulation:	± 2% Over input variation
Load Regulation:	± 4%
Ripple and Noise:	700mV max, 20MHz B.W.
Typical Efficiency	88% @ 18Vdc, max load
Output Protection:	Over-Voltage and Over-Current, reset by power cycling

Environmental Specifications

Maximum Case Temp.	85°C
Storage Temperature:	-40°C to +85°C
Humidity:	5% to 95%
Cooling:	Convection
Sound Rating:	Class A
Vibration Frequency:	5-55 Hz/2g, 30 minutes
Impact Resistance:	1g/s
MTBF:	482,000 Hours @ full load per MIL-217F Notice 2
EMC:	FCC 47CFR Part 15 Class B compliant
Weight:	7.0 oz. (198 g)



- Total Power: 25 Watts
- Input Voltage: 12-24 Vdc
- UL Dry & Damp Location Rated
- IP66 & NEMA4
- EN60950, CE Compliant

Constant Current Product Specifications

Part Number	Output Current (mA ±4%)	Output Voltage Range (Vdc)	Max Output Power (W)	Typical Efficiency
LDC25W-072-C0350	350	36-72	25	90%
LDC25W-056-C0450	450	19-56	25	89%
LDC25W-036-C0700	700	18-36	25	88%
LDC25W-024-C1040	1040	12-24	25	86%

Constant Voltage Product Specifications

Part Number	Output Voltage (Vdc ±5%)	Output Current Range (mA)	Max Output Power (W)	Typical Efficiency
LDC25W-024	24	260-1040	25	86%
LDC25W-036	36	175-700	25	88%
LDC25W-056	56	113-450	25	89%
LDC25W-072	72	88-350	25	90%

Class 2: US/Canada US Only



Note:
LED drivers are designed and intended to operate LED loads only. Non-LED loading may be outside the specified design limits of our LED drivers, and therefore cannot be covered by any warranty. If you desire to use our LED drivers to operate non-LED loads please contact us to discuss compatibility.

Specifications subject to change without notice.

Rev 9-2-15

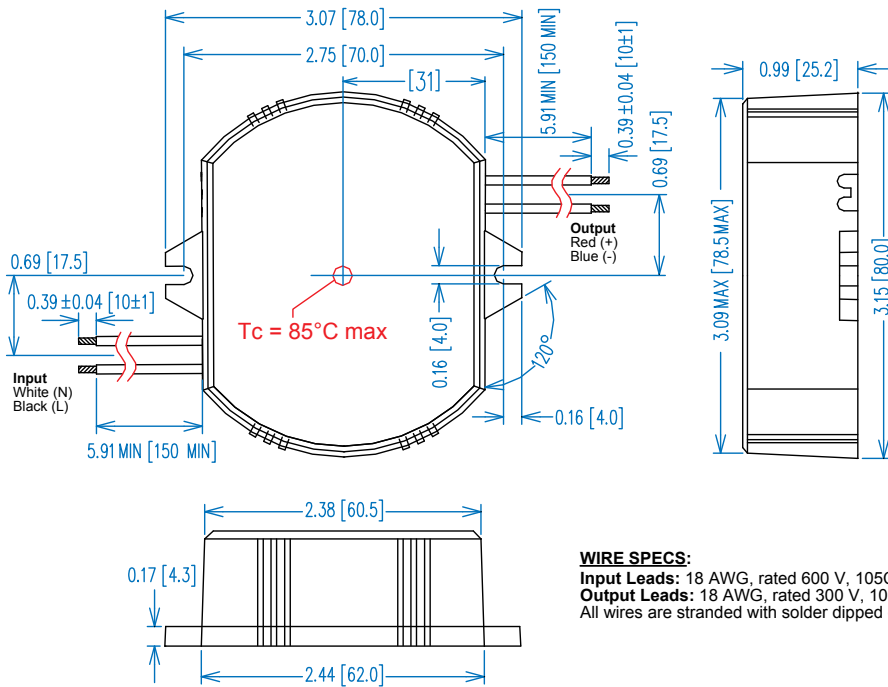

WIRE SPECS:
Input Leads: 18 AWG, rated 600 V, 105C, min.
Output Leads: 18 AWG, rated 300 V, 105C, min.
 All wires are stranded with solder dipped ends.

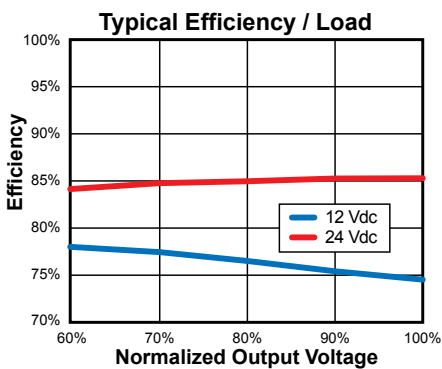
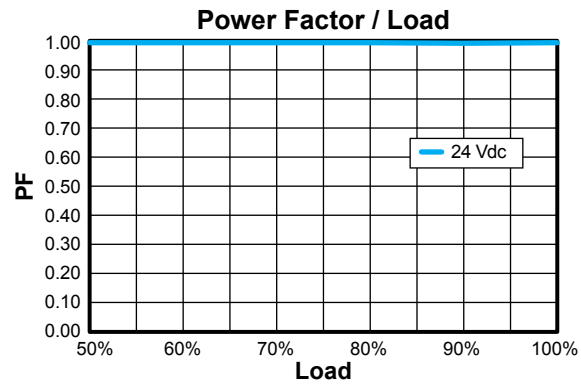
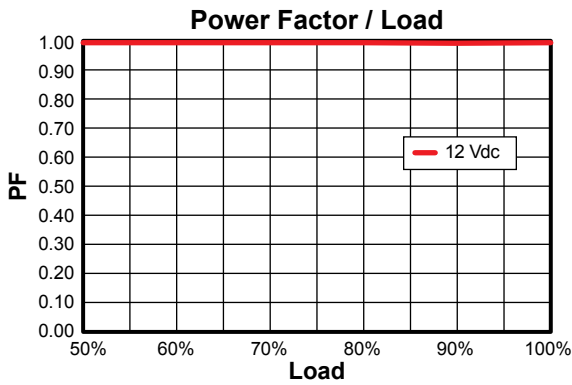

Note:
 Disconnect power to LED driver for at least 30 seconds before connecting or disconnecting Driver output and LED Engine. This prevents potential arcing transients that can damage the Engine and Driver. See Hot Plugging in our Driver Application Guide for more information.

UL Conditions of Acceptability

See website for additional information