

Super-mini Signal Conditioners Mini-M Series

ENCODER SPEED TRANSMITTER

(PC programmable; built-in excitation)

Functions & Features

- Converts a two-phase forward and reverse rotation pulse signal with 90 degree phase difference into a forward and reverse speed signal
- Built-in excitation
- PC programmable input and output ranges
- Input pulse monitoring LED
- Direct RS-422 input

Typical Applications

- Measuring moving speed of a machine with a rotary encoder

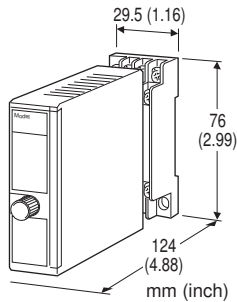

MODEL: M2XRP2-[1][2][3]-[4][5]

ORDERING INFORMATION

- Code number: M2XRP2-[1][2][3]-[4][5]
Specify a code from below for each [1] through [5].
(e.g. M2XRP2-000-M2/CE/Q)
 - Specify the specification for option code /Q
(e.g. /C01/S01)
 - Non-specified orders will be shipped at default factory settings (M2XRP2-000: Open collector input/12 V excitation/4 – 20 mA output). However, a power suffix code must be specified.
- If you specify a full code number without specific calibration ranges, the input frequency is factory set to the maximum range available for the selected input code and the output is set to the default range. Use Ordering Information Sheet (No. ESU-5059).

Note: Must be used with its socket. NOT installable to a multi-unit installation base. (e.g. model: M2BS-16)

[1] INPUT

0: User-calibrated (Factory default: open collector, 0 – 100 kHz)

If the unit is to be factory-calibrated to a specific input type, please select from the following:

- A: Open collector
- B: Voltage pulse
- J: RS-422 line driver pulse

[2] EXCITATION

0: User-calibrated (Factory default: 12 V DC / 5 mA)

If the unit is to be factory-calibrated to a specific voltage value, please select from the following:

- 1: 5 V DC / 5 mA
- 4: 12 V DC / 5 mA

[3] OUTPUT

0: User-calibrated (Factory default: 4 – 20 mA)

If the unit is to be factory-calibrated to a specific output type, please select from the following:

Current

Z1: Range 0 – 20 mA DC

Voltage

V1: Range -2.5 – +2.5 V DC

V2: Range -10 – +10 V DC

(Configurator software is used to change output over the described range of the selected suffix code. For changing out of this range, set the Output Range Selectors inside the unit before software adjustment.)

[4] POWER INPUT

AC Power

M2: 100 – 240 V AC (Operational voltage range 85 – 264 V, 47 – 66 Hz)
(90 – 264 V for UL)

DC Power

R: 24 V DC
(Operational voltage range 24 V ±10 %, ripple 10 %p-p max.)
P: 110 V DC
(Operational voltage range 85 – 150 V, ripple 10 %p-p max.)
(110 V ±10 % for UL)

[5] OPTIONS (multiple selections)

Standards & Approvals (must be specified)

/N: Without CE or UL

/CE: CE marking

/UL: UL approval, CE marking

Other Options

blank: none

/Q: Option other than the above (specify the specification)

SPECIFICATIONS OF OPTION: Q (multiple selections)

COATING (For the detail, refer to M-System's web site.)

/C01: Silicone coating

/C02: Polyurethane coating

/C03: Rubber coating (UL not available)

TERMINAL SCREW MATERIAL

/S01: Stainless steel (UL not available)

RELATED PRODUCTS

- PC configurator software (model: JXCON)

Downloadable at M-System's web site.

A dedicated cable is required to connect the module to the PC. Please refer to the internet software download site or the users manual for the PC configurator for applicable cable types.

GENERAL SPECIFICATIONS

Construction: Plug-in

Connection: M3 screw terminals (torque 0.8 N·m)

Screw terminal: Chromated steel (standard) or stainless steel

Housing material: Flame-resistant resin (black)

Isolation: Input to output to power

Overrange output: Approx. -15 to +115 % at 1 - 5 V

Zero adjustment: -5 to +5 % (front)

Span adjustment: 95 to 105 % (front)

Configuration: Via PC Configurator Software (model:JXCON) on the Windows PC connected to the front jack.

Programmable features include:

- I/O type and range
- Zero and span adjustments
- Low-end cutout
- Linearization

Status indicator LED: Red LED; Flashing patterns indicate different operating status of the transmitter.

Input monitor (PL1): Green LED blinks according to the input phase A.

Input monitor (PL2): Green LED blinks according to the input phase B.

Excitation adjustment: 5V or 12V DC

Configurator connection: 2.5 dia. miniature jack;

RS-232-C level

Pulse sensing: DC coupled or capacitor coupled selectable with DIP SW

Low-end cutout: 100 msec. - 100 sec. or no cutout programmable

INPUT SPECIFICATIONS

Excitation: Shortcircuit protection; 20 mA max. at shortcircuit

Maximum frequency: 200 kHz

Frequency ranges:

0 - 10 mHz, 0 - 100 mHz, 0 - 1 Hz, 0 - 10 Hz, 0 - 100 Hz, 0 - 1 kHz, 0 - 10 kHz, 0 - 100 kHz

(Choose 100 kHz range to set the zero/span frequencies lower than -100 kHz (higher than 100 kHz in the reverse direction) or higher than 100 kHz (higher than 100 kHz in the forward direction.))

Minimum pulse width time requirement: 2.5 µsec.

Minimum span: 10 % of the selected frequency range

Noise filter: See table 2

■ Open Collector

Input requirements

EXCITATION	SENSING	OFF	ON
5 V	Approx. 5 V	≥200 kΩ	≤200 Ω
12 V	Approx. 10 V	≥200 kΩ	≤200 Ω

Amplitude: 5 - 12 V

Detecting level:

5 V excitation: 1 V

12 V excitation: 2 V

(Detecting voltage in the internal circuit.)

For open collector input, be sure to re-adjust the voltage back to 1 V (5 V excitation) or 2 V (12 V excitation) if it has been changed for other input types.)

Detecting pulse edge: OFF to ON

If not specified, the input range is 0 Hz - 1 kHz.

■ Voltage Pulse

Waveform: Square or sine

Input impedance: 10 kΩ min.

Pulse amplitude: 0.1 - 30 Vp-p

Pulse amplitude Range: See table 1.

Max. voltage between input terminals: See table 1.

Sensitivity Scale: See table 1.

Detecting level: -2 - +4 V

Detecting pulse state: A pulse rise detected when the input voltage goes above the detecting level; a pulse sink detected when it goes below the level.

If not specified, the input range is 0 Hz - 1 kHz.

■ RS-422 Line Driver Pulse

Receiver: Conforms to RS-422

If not specified, the input range is 0 Hz - 1 kHz.

[Table 1]

PULSE AMPLITUDE RANGE	MAX.INPUT VOLTAGE	SENSITIVITY SCALE
10 – 30 Vp-p	30 V	1/6
5 – 10 Vp-p	10 V	1/2
1 – 5 Vp-p	5 V	1
0.1 – 1 Vp-p*	1 V	5

*Input frequency within ± 50 kHz

When the parameters have been set with DIP switches and the PC Configurator Software (model: JXCON), a specific sensitivity scale is applied according to the pulse amplitude setting. The scaled input voltage is then compared to the preset detecting level (-2.00 to +4.00 V).

With DC coupling, the scaled maximum voltage must be higher than the detecting level and the minimum voltage must be lower than that so that the pulse state is accurately detected. (Refer to the instruction manual for detailed information about adjusting the detecting level.)

[Table 2]

FREQUENCY RANGE	NOISE FILTER TYPE
0 – 10 mHz	With
0 – 100 mHz	With
0 – 1 Hz	With
0 – 10 Hz	W/O
0 – 100 Hz	W/O
0 – 1 kHz	W/O
0 – 10 kHz	W/O
0 – 100 kHz	W/O

Be sure to apply the noise filter appropriate for the selected frequency range as shown in the table above. The accuracy may not be assured if no filter is applied.

OUTPUT SPECIFICATIONS

■ DC Current

Output range: 0 – 20 mA DC

Conformance range: 0 – 23mA DC

Minimum span: 1 mA

Offset: Lower range can be any specific value within the output range provided that the minimum span is maintained.

Load resistance: Output drive 12 V max.

(e.g. 4 – 20 mA: 600 Ω [12 V \div 20 mA])

If not specified, the output range is 4 – 20 mA DC.

■ DC Voltage

Code V1 (narrow spans)

Conformance range: -3 – +3 V DC

Output range: -2.5 – +2.5 V DC

Minimum span: 250 mV

Code V2 (wide spans)

Conformance range: -11.5 – +11.5 V DC

Output range: -10 – +10 V DC

Minimum span: 1 V

Offset: Lower range can be any specific value within the output range provided that the minimum span is maintained.

Load resistance: Output drive 1 mA max.

(e.g. 1 – 5 V: 5000 Ω [5 V \div 1 mA])

If not specified, the output range is shown below.

V1: 0 – 1 V DC

V2: 1 – 5 V DC

INSTALLATION

Power Consumption

•AC:

Approx. 4 VA at 100 V

Approx. 5 VA at 200 V

Approx. 6 VA at 264 V

•DC: Approx. 3 W

Operating temperature: -5 to +55°C (23 to 131°F)

Operating humidity: 30 to 90 %RH (non-condensing)

Mounting: Surface or DIN rail

Weight: 150 g (0.33 lb)

PERFORMANCE

Accuracy: Input accuracy + output accuracy

Input accuracy: $\leq \pm 0.03\%$ of the selected freq. range

Output accuracy: $\leq \pm 0.03\%$ of the selected output range

The input accuracy is inversely proportional to the input span; while the output accuracy is likewise inversely proportional to the output span. With [Input Range / Input Span] ≤ 1 , the input accuracy is fixed at $\pm 0.03\%$.

See CALCULATION EXAMPLES OF OVERALL ACCURACY.

Temp. coefficient: $\pm 0.015\%/^{\circ}\text{C}$ ($\pm 0.008\%/^{\circ}\text{F}$) of I/O range at -5 to +55°C [23 to 131°F]

Response time: 0.5 sec. + 1 pulse cycle (0 – 90 %)

Line voltage effect: $\pm 0.1\%$ over voltage range

Insulation resistance: $\geq 100\text{ M}\Omega$ with 500 V DC

Dielectric strength: 2000 V AC @1 minute (input to output to power to ground)

CALCULATION EXAMPLES OF OVERALL ACCURACY

[Example] Open collector input, 0 – 50 kHz; 1 – 5 V output.

Selected freq. range (100 kHz) \div Input span (50 kHz) \times

Accuracy (0.03 %) = 0.06 % (Input accuracy)

Selected output range (20 V) \div Output span (4 V) \times

Accuracy (0.03 %) = 0.15 % (Output accuracy)

Overall accuracy = 0.06 + 0.15 = $\pm 0.21\%$

STANDARDS & APPROVALS

EU conformity:

EMC Directive

EMI EN 61000-6-4

EMS EN 61000-6-2

Low Voltage Directive

EN 61010-1

Installation Category II

Pollution Degree 2

Input or output to power: Reinforced insulation (300 V)

Input to output: Basic insulation (300 V)

RoHS Directive

EN 50581

Approval:

UL/C-UL nonincendive Class I, Division 2,

Groups A, B, C, and D

(ANSI/ISA-12.12.01, CAN/CSA-C22.2 No.213)

UL/C-UL general safety requirements

(UL 61010-1, CAN/CSA-C22.2 No.61010-1)

EXTERNAL VIEW

FRONT VIEW (with cover open)

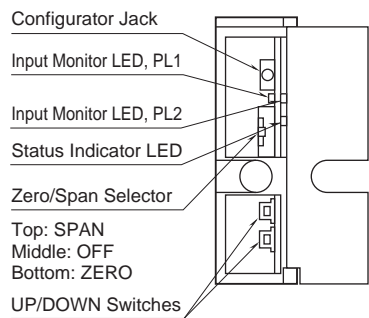

The front cover cannot be opened to 180 deg. when flush with neighboring units.

LEFT SIDE VIEW (with cover removed)

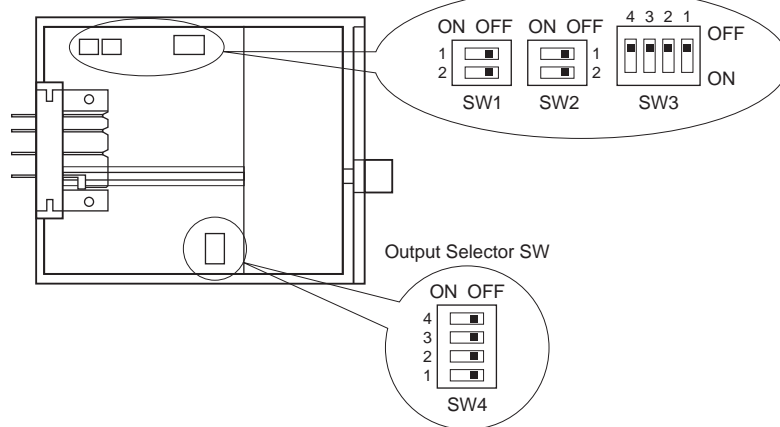

Refer to the instruction manual for detailed procedures.

OPERATION

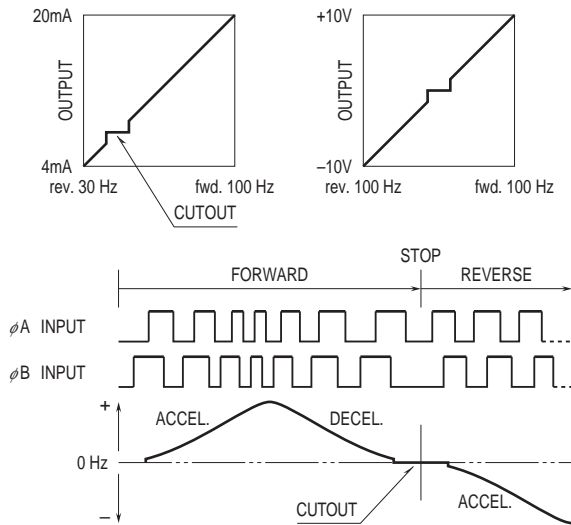

Forward Rotation: Phase A leads the Phase B by 90 degrees.
 Reverse Rotation: Phase A lags behind Phase B by 90 degrees.

EXTERNAL DIMENSIONS & TERMINAL ASSIGNMENTS unit: mm (inch)

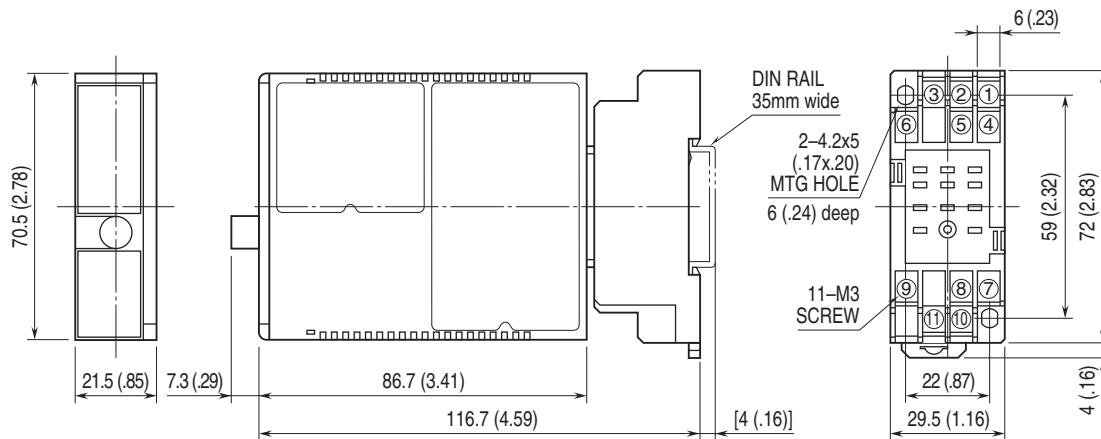

• When mounting, no extra space is needed between units.

SCHEMATIC CIRCUITRY & CONNECTION DIAGRAM

■ OPEN COLLECTOR, VOLTAGE INPUT

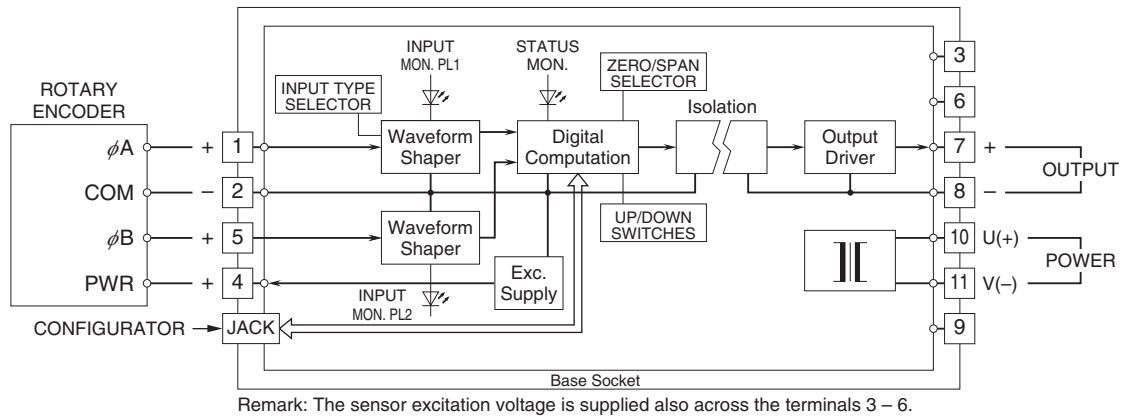

■ RS-422 LINE DRIVER INPUT

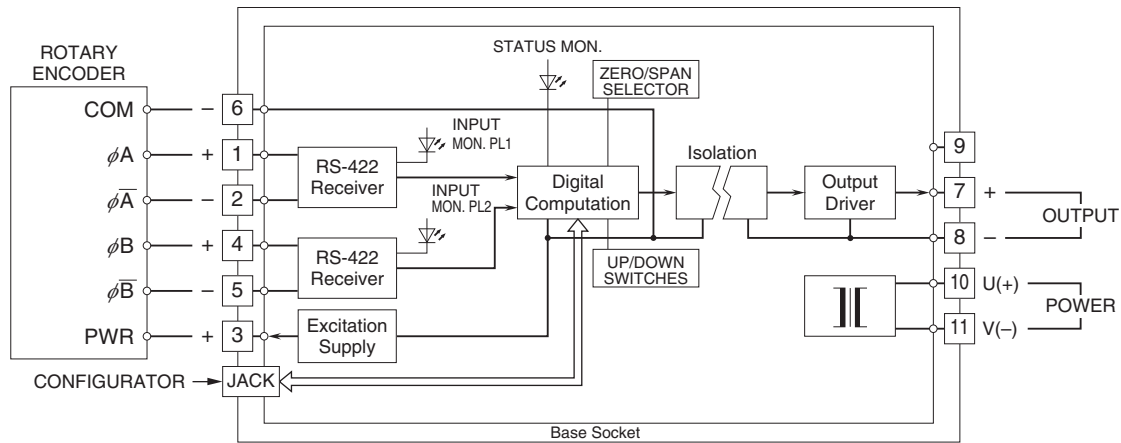

Specifications are subject to change without notice.