



## FEATURES

### GENERAL FEATURES

- Five independent 3/1.5Gbps SATA ports.
- Connects 1 host port to 4 device ports.
- Supports 3/1.5Gbps rate detection/speed negotiation.
- Supports power down modes - Active, partial, slumber and power down.
- Advanced features configurable through MDIO bus.

### PORT MULTIPLIER LOGIC FEATURES

- Low latency architecture.
- Supports OOB signaling for SATA applications. Internal OOB detectors for COMRESET/COMINIT and COMWAKE.

### HIGH SPEED I/O FEATURES

- High speed outputs with programmable pre-emphasis to drive long interconnects.
- Selectable high speed input equalization for optimum reception.
- Compliant with SATA Gen-2i & Gen-2m specification.
- Enables reliable data transmission over 1 meter or more of FR-4 and 4 meters or more of unequalized copper cable.
- Supports spread spectrum clocking (SSC) to reduce EMI.

### PHYSICAL FEATURES

- CMOS 0.13 Micron Technology
- Single 1.2 V Power Supply
- -40°C to 85°C Industrial Temperature Range
- No heatsink or airflow required
- 100-Pin LQFP Package

## 1.0 INTRODUCTION

The XRS10L140 provides the advantages of the Serial ATA II Port Multiplier implementations for Serial ATA II systems at 3.0 Gbps and 1.5 Gbps. The XRS10L140 offers a leading solution for propagation of high data rate Serial ATA products in a wide variety of applications. The integration of Serial ATA PHY links, a variety of digital logic capabilities, rate adjust FIFOs, integrated low-cost clock oscillator support,

test and loopback features is achieved in a low cost and lower power implementation.

The port multiplier function is used when one active host has to communicate with multiple SATA drives. The XRS10L140 supports up to 4 SATA drives and utilizes the full bandwidth of the host connection.

The XRS10L140 includes enhanced features such as staggered HDD spin-up, power management control, hot plug capability and support for legacy software. The XRS10L140 acts as a retimer, maintaining independent signaling domains between the drives, hosts and the external interconnect.

The high-speed serial input feature: selectable equalization and the high-speed serial output feature: programmable pre-emphasis can be used to compensate for ISI (Inter-Symbol Interference) and increase maximum cable distances.

XRS10L140 meets tight jitter budgets in SATA applications. Exar's serial I/O technology enables reliable data transmission over 1 meter or more of FR-4 and 4 meters or more of unequalized copper cable.

Host and drive port speeds can be mixed and matched, based upon inherent data rate negotiation present in the SATA II specifications.

The MDIO bus allows simple configuration of the XRS10L140 when needed. Receive equalization, transmit amplitude and pre-emphasis and SSC control are all configurable via the 2-wire MDIO interface.

To summarize, the port multiplier functionality in the XRS10L140 allows the system designer to increase the number of serial ATA connections in an enclosure that does not have a sufficient number of serial ATA connections for all of the drives in the enclosure.

## STANDARDS COMPLIANCE

The XRS10L140 is compliant with the following industry specifications:

- Serial ATA, Revision 1.0a
- Serial ATA II: Extensions to Serial ATA 1.0a, Revision 1.2
- Serial ATA II PHY Electrical Specifications, Revision 1.0
- Serial ATA II: Port Multiplier, Revision 1.2
- Serial ATA II: Revision 2.6

**APPLICATIONS**

- Serial ATA Enclosures
- Other Serial ATA link replicator applications
- Buffers for externally connected links
- High density storage boxes
- RAID Subsystems

**APPLICATION EXAMPLE**

The XRS10L140 is ideally suited for use within an external drive enclosure as a means of providing redundant host access to ensure system availability and reliability, while enabling access to up to four target devices per XRS10L140. This application is shown in **Figure 1**. Other applications for the XRS10L140 include use in fixed-content or network attached storage systems, storage arrays, desktop applications or entry-level servers, RAID storage or disk-to-disk backup.

**FIGURE 1. SYSTEM BLOCK DIAGRAM FOR XRS10L140 IN A DRIVE ENCLOSURE APPLICATION**

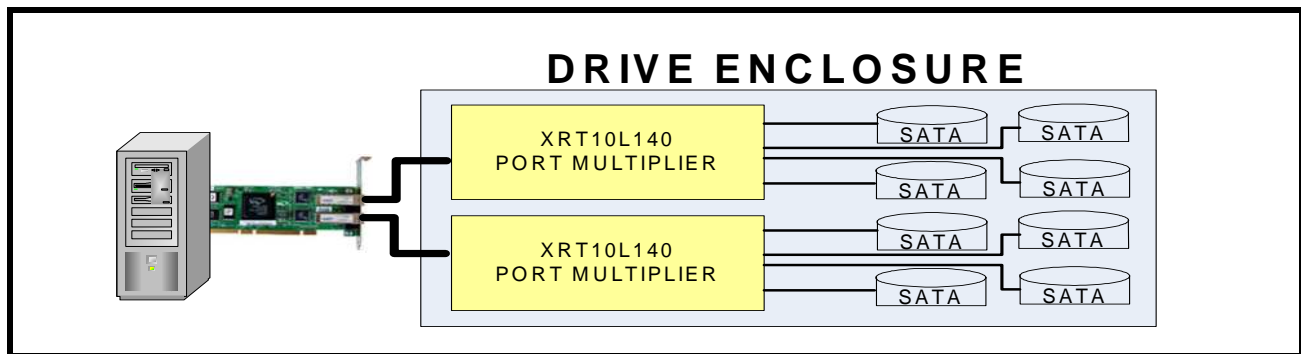
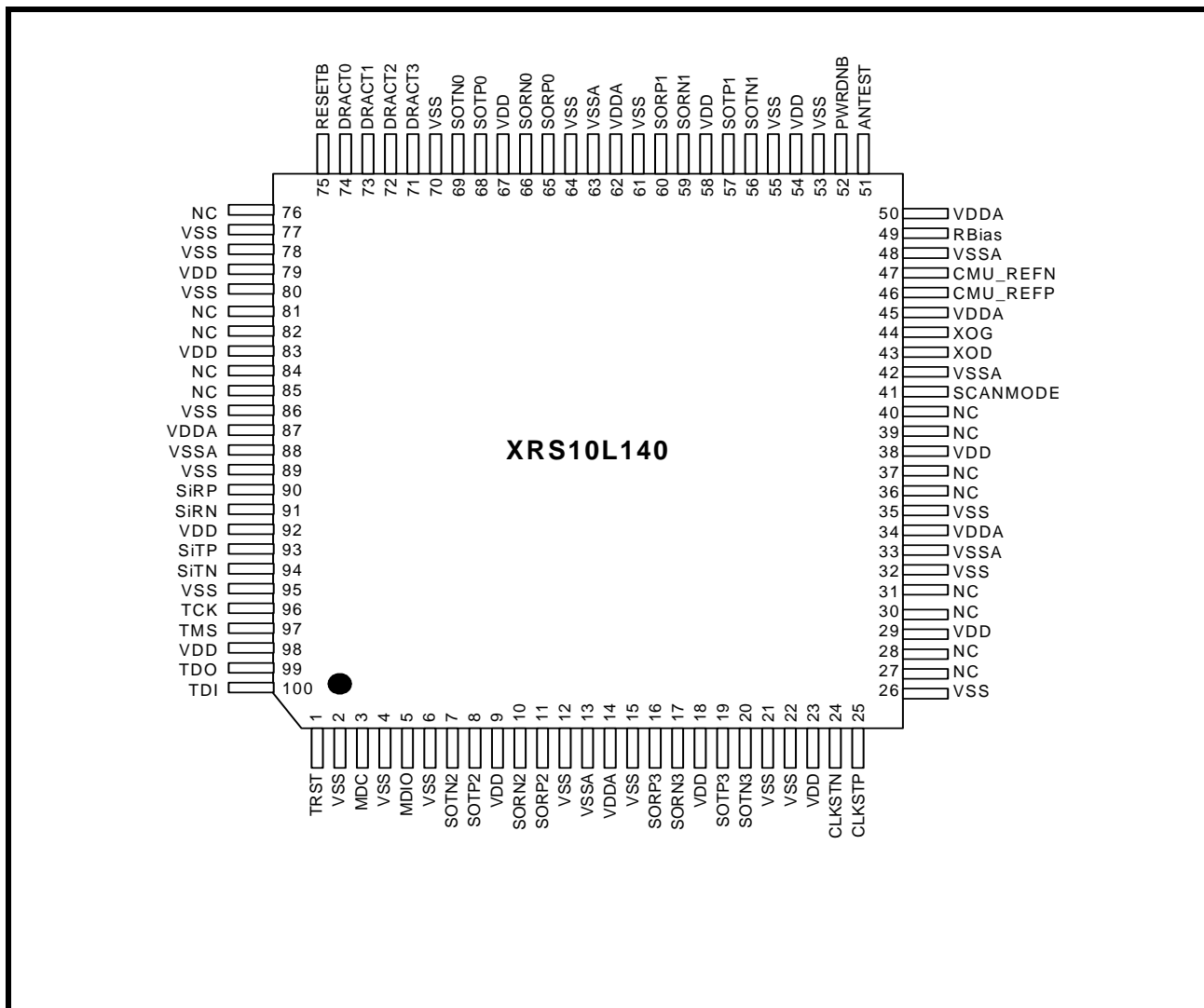

FIGURE 2. PINOUT OF THE XRS10L140



## 2.0 PIN DESCRIPTIONS

TABLE 1: XRS10L140 PIN DESCRIPTIONS

Pin Name	Pin Number	I/O		DESCRIPTION
<b>DATA INTERFACE</b>				
SOTP0/SOTN0	68, 69	O	CML AC Coupled	Serial ATA Output Transmitters. These ports communicate from the XRS10L140 to downstream devices
SOTP1/SOTN1	57, 56			
SOTP2/SOTN2	8, 7			
SOTP3/SOTN3	19, 20			
SORP0/SORN0	65, 66	I	CML AC Coupled	Serial ATA Input Receivers. These ports receive signals from downstream devices
SORP1/SORN1	60, 59			
SORP2/SORN2	11, 10			
SORP3/SORN3	16, 17			
SITP/SITN	93, 94	O	CML AC Coupled	Serial ATA Output Transmitters. These ports communicate from the XRS10L140 to upstream hosts.
SIRP/SIRN	90, 91	I	CML AC Coupled	Serial ATA Input Receivers. These ports receive signals from upstream hosts.
<b>CLOCK INTERFACE</b>				
CMU_REFP/ CMU_REFN	46, 47	I	CML AC Coupled	Reference clock input
XOD	43	O	Analog	Crystal oscillator output
XOG	44	I	Analog	Crystal oscillator input, 1.26V max
<b>MDIO INTERFACE SIGNALS</b>				
MDC	3	I	LVC MOS	MDIO clock input, +3.3V LVC MOS
MDIO	5	I/O	LVC MOS	MDIO data port, +3.3V LVC MOS. Open drain
<b>JTAG Interface Signals</b>				
TCK	96	I	LVC MOS	JTAG test clock, +3.3V LVC MOS
TDI	100	I		JTAG test data in, +3.3V LVC MOS.
TDO	99	O		JTAG test data out, +3.3V LVC MOS. Open drain. If used to daisy chain JTAG devices, pull up externally using 3.3KOhm resistor.
TMS	97	I		JTAG mode select, +3.3V LVC MOS.
TRST	1	I		JTAG test reset, +3.3V LVC MOS. Pull low externally using 3.3KOhm resistor for normal operation of the device.
<b>GENERAL CONTROL AND CONFIGURATION SIGNALS (CMOS)</b>				
RBIAS	49	I	Analog	Connection point for calibration termination resistor.
RESETB	75	I	LVC MOS	Active low reset pin, +3.3V LVC MOS.



TABLE 1: XRS10L140 PIN DESCRIPTIONS

Pin Name	Pin Number	I/O		DESCRIPTION
PWRDNB	52	I	LVC MOS	Active low power down signal for chip, +3.3V LVC MOS.
DRACT[3:0]	71, 72, 73, 74	O	LVC MOS	Drive activity port for external LED. Active Low, 3.3V LVC MOS, open drain
<b>TEST PIN</b>				
ANTEST	51	O	Analog	Analog test pin
CLKSTN/ CLKSTP	24, 25	O	CML AC Coupled	Output clock test pin
<b>RESERVED PINS</b>				
NC	27, 28, 30, 31, 36, 37, 39, 40, 76, 81, 82, 84, 85			No Connect
SCANMODE	41	I	LVC MOS	For factory use only. connect to ground.
<b>POWER AND GROUND SIGNALS</b>				
VDD	9, 18, 23, 29, 38, 54, 58, 67, 79, 83, 92, 98	I		1.2V supply.
VDDA	14, 34, 45, 50, 62, 87	I		1.2V Analog supply.
VSS	2, 4, 6, 12, 15, 21, 22, 26, 32, 35, 53, 55, 61, 64, 70, 77, 78, 80, 86, 89, 95	I		Ground.
VSSA	13, 33, 42, 48, 63, 88	I		Analog Ground.

### 3.0 FUNCTIONAL DESCRIPTION

A top-level view of the XRS10L140 is shown in **Figure 3** outlining the interfaces to the device and the required support components. The data path can be seen at the top of the device. This includes the output transmit and input receive paths at the top left, providing the upstream interface to the host, and the four output transmit and input receive paths at the top right, providing the downstream interface to the target devices. The clocking, control, and configuration interfaces are shown below the dotted line.

**FIGURE 3. XRS10L140 INTERFACES**

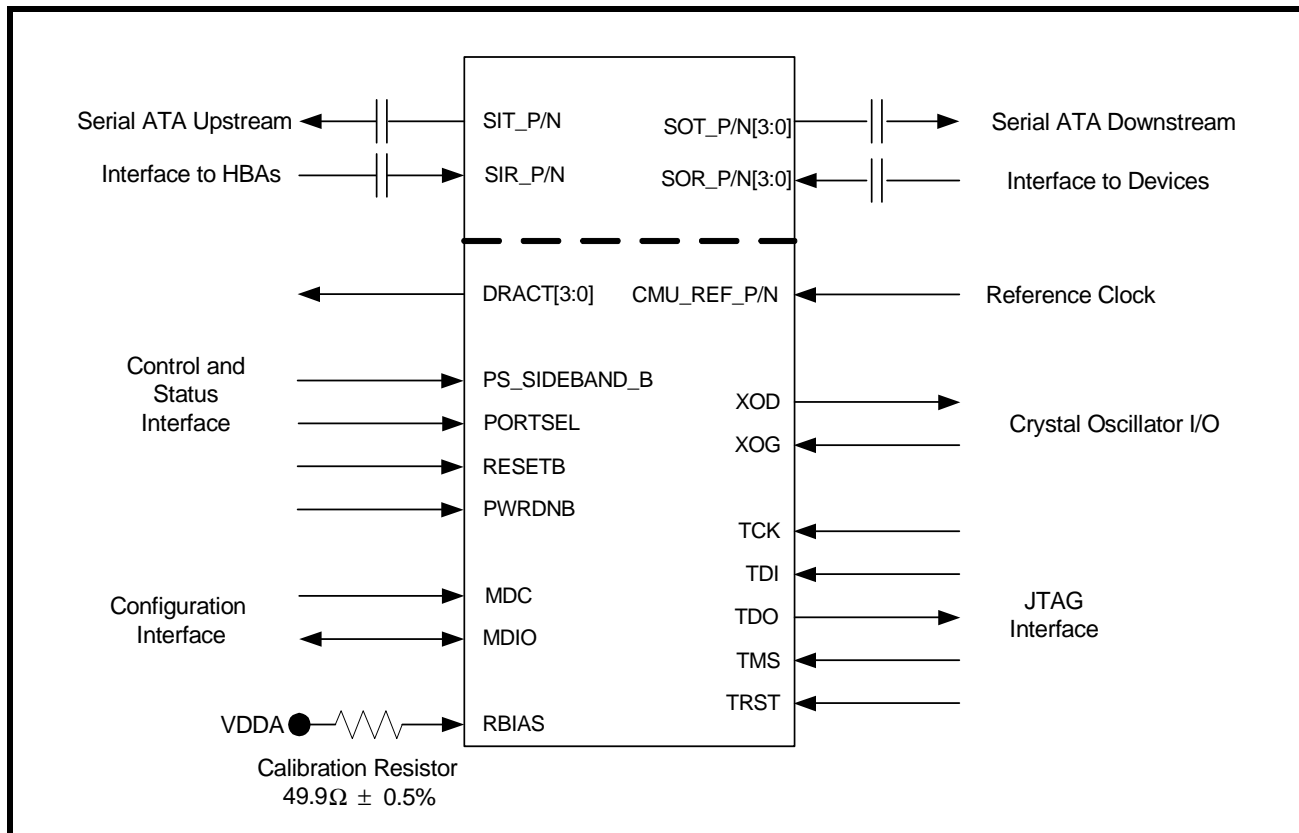

The XRS10L140 incorporates identical instantiations of a dual-channel Serial ATA II 3 Gbps PHY macro. This common building block provides a uniform implementation with common characteristics and a common register map, but provides a functional implementation of independent PHY blocks. Digital logic implementations of Serial ATA link layer blocks along with port multiplier logic provide the remainder of the data path within the XRS10L140. In addition, management and control interfaces including an MDIO interface for

register control, a JTAG interface for boundary scan purposes, and a resistor calibration circuit complete the device. A block diagram of the XRS10L140 is shown in **Figure 4**.

**FIGURE 4. XRS10L140 BLOCK DIAGRAM**

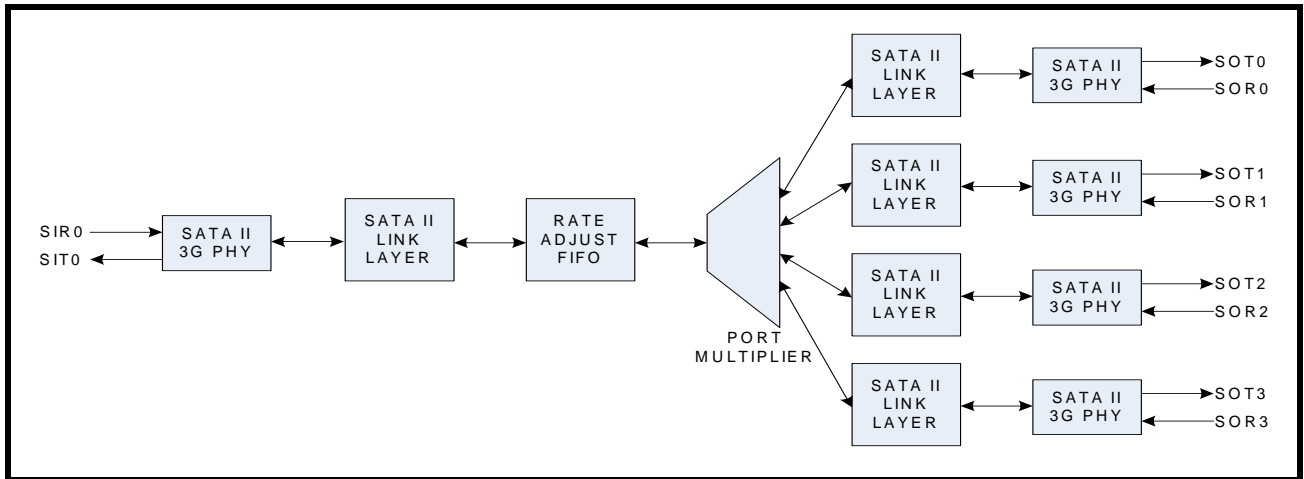

### 3.1 Out Of Band Feature

Each Serial ATA link provides full support for the three Out Of Band (OOB) signals supported by Serial ATA: COMRESET, COMINIT and COMWAKE. These sequences must be separated by idle periods as shown in **Figure 5**. The sequences are comprised of 106.7ns bursts of activity that are interleaved with varying length stretches of electrical idle. This alternating sequence must be repeated four times to be recognized.

**FIGURE 5. COMWAKE AND COMRESET/COMINIT SEQUENCES**

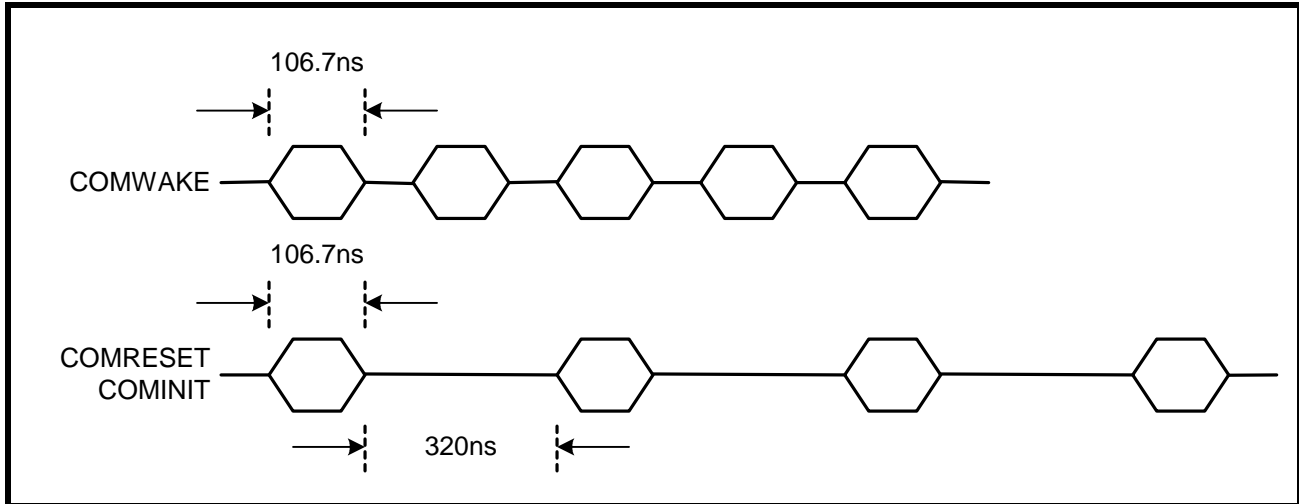

An example OOB sequence and the resulting burst and idle widths are shown in **Figure 6**. If the sequence of burstWidth and idleWidth counts falls within the range specified in the MDIO registers for four consecutive burst/idle sequences, then the link will assert COMINIT or COMWAKE. This OOB signal will remain asserted for as long as the corresponding sequence on the input pins continues.

**FIGURE 6. EXAMPLE OOB SEQUENCE**

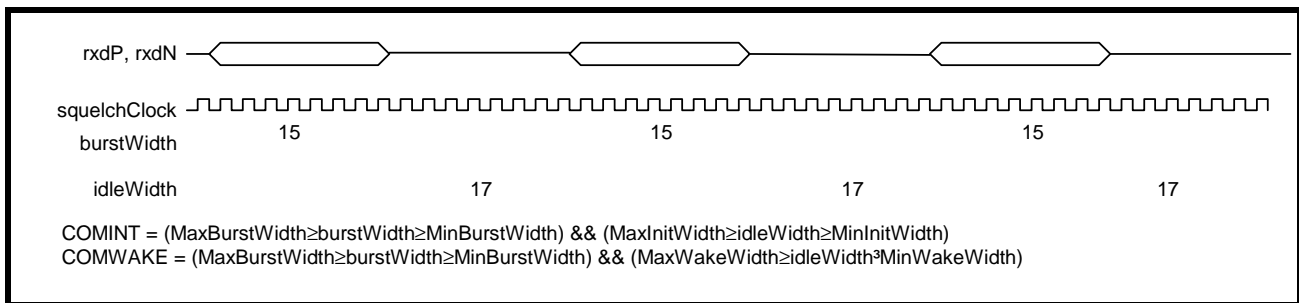

### 3.2 Power Down Modes

The XRS10L240 features independent support for the 3 power modes, as follows:

- Active: All parts of the link are active. All power-down signals are de-asserted.
- Partial: In partial mode, the input and output pipelines are shut down, but the PLL and the OOB generation circuits are active.
- Slumber: In slumber mode, the PLL is also shut down, saving additional power but adding latency on exit.

The XRS10L240 transceiver components (transmitter, receive CDR, PLL, etc.) can be powered down through MDIO register settings. **Please refer to Table 12, “Powerdown Registers (MDIO Devices 1, 2 & 3),” on page 26**

Please refer to “XRS10L240/140 Errata Sheet” for details regarding Link Power Management.

### 3.3 Speed Negotiation

The XRS10L140 will automatically perform speed negotiation with the host and devices in order to verify whether the second generation Serial ATA 3.0 Gbps data rate is available or whether the system will need to fall back upon the first generation Serial ATA 1.5 Gbps data rate. Speed negotiation is performed on an independent basis by each of the dual-channel macros. Speed negotiation is done independently on all host and device ports by default. MDIO configuration can request a common negotiated speed on the host and device ports if such a speed exists. To perform speed negotiation with a downstream device, the XRS10L140 will first perform a COMRESET/COMINIT handshake with the device and then performs a calibrate/COMWAKE handshake. Following receipt of the device COMWAKE signal, the XRS10L140 will continually send out a D10.2 signal while awaiting receipt of the device ALIGN primitive. Depending on the speed of the ALIGN primitive, the XRS10L140 will be able to determine the PHY generation of the device, and provide the appropriate 1.5 Gbps or 3.0 Gbps ALIGN primitive in return to the device, thus completing speed negotiation. This process is outlined in **Figure 7**.

**FIGURE 7. SERIAL ATA SPEED NEGOTIATION**

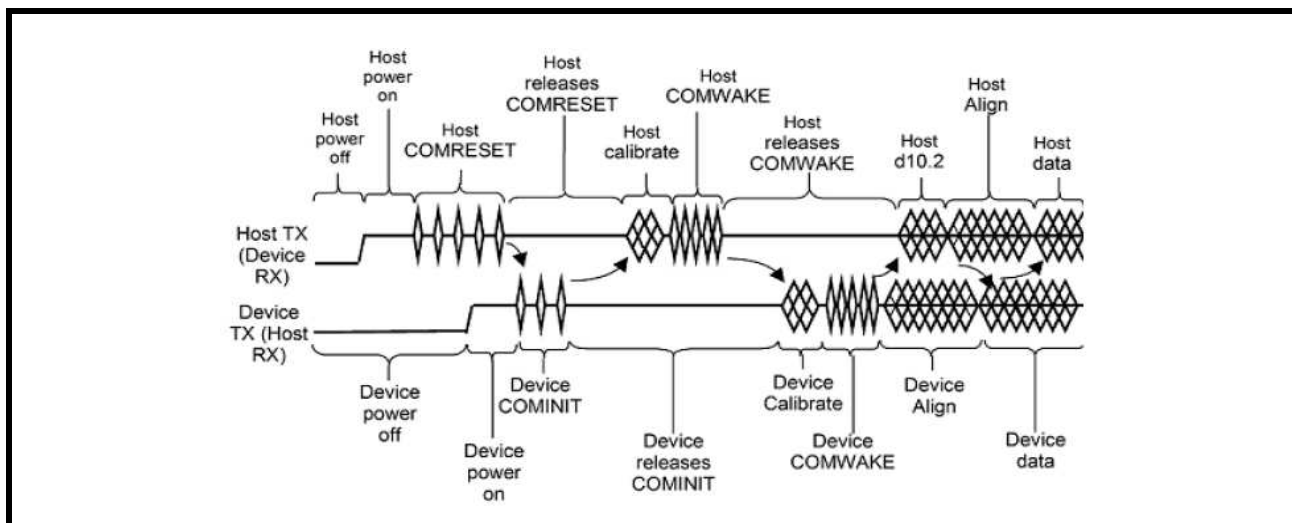

For speed negotiation with an upstream host, after the COMRESET/COMINIT and COMWAKE handshake is complete, the XRS10L140 will initially send out an ALIGN primitive at the 2nd generation 3.0 Gbps data rate. If no confirming 3.0 Gbps ALIGN primitive is received from the host, the XRS10L140 will then step down and attempt negotiation at the lower 1.5 Gbps data rate.

### 3.4 Port Multiplier Implementation

The XRS10L140 provides full support for the functionality outlined in the Serial ATA II Port Multiplier specification. A Serial ATA II Port Multiplier is a mechanism for one active host connection to communicate

with multiple devices. A Port Multiplier is conceptually a simple multiplexer in which one active host connection is multiplexed to multiple device connections.

The XRS10L140 uses four bits, known as the PM Port field in all Serial ATA frame types, to route frames between the selected host and the appropriate device. PM ports 0 through 3 are valid device ports within the 4-output XRS10L140, while PM port 15 is designated for communication between the host and the XRS10L140 itself. For host-to-device transactions, the PM Port field is designated by the host in order to specify which device the frame is intended for. For device-to-host transactions, the XRS10L140 fills in the PM Port field with the port address of the device that is transmitting the frame.

The PM Port field is defined in the Serial ATA port multiplier specification to be the first 32-bit Dword in the Frame Information Structure (FIS) for all FIS types, as shown in **Figure 8**.

**FIGURE 8. PORT SELECTION SIGNAL - TRANSMITTED COMRESET SIGNALS**

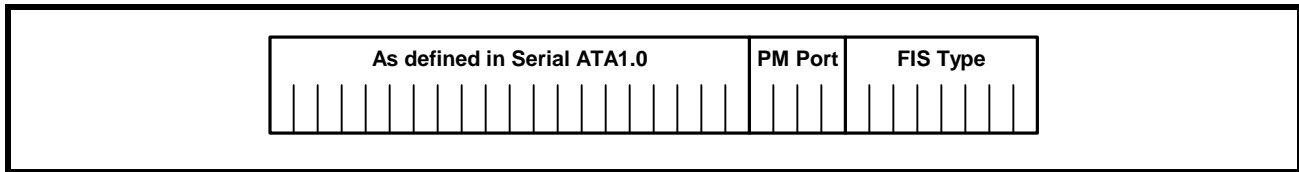

**3.4.1 Transmission from a host to a device**

A host indicates the target device for receipt of a transmitted frame by setting the PM Port field in the frame to the device's port address. When an XRS10L140 receives a frame from the host, it checks the PM Port field in the frame to determine which port address should be used. If the frame is set for transmission to the control port (15), the XRS10L140 receives the frame and performs the command or operation requested. If the frame is designated for a device port, the XRS10L140 obeys the following procedure:

1. The XRS10L140 first determines if the device port is valid. If the device port is not valid, the XRS10L140 will issue a SYNC primitive to the host and terminate reception of the frame.
2. The XRS10L140 determines if the X bit is set in the device port's PSCR[1] (SError) register. If the X bit is set, the XRS10L140 issues a SYNC primitive to the host and terminates reception of the frame.
3. The XRS10L140 determines if a collision has occurred. A collision occurs when a reception is already in progress from the device that the host wants to transmit to. If a collision has occurred, the XRS10L140 will finish receiving the frame from the host and will then issue an R\_ERR primitive to the host as the ending status. The XRS10L140 will then discard the frame, but will not return an R\_RDY primitive to the host until the frame from the affected device port has been transmitted to the host, thus indicating to the host when it can retry to send the frame. The transmission from the device will proceed as requested, as the device will always take collision precedence over the host.
4. The XRS10L140 initiates a transfer with the device by issuing an X\_RDY primitive to the device. A collision may occur as the XRS10L140 is issuing the X\_RDY to the device if the device has started transmitting an X\_RDY primitive to the XRS10L140, indicating a decision to start a transmission to the host. In this case, the XRS10L140 will finish receiving the frame from the host and then issue an R\_ERR primitive to the host to indicate an unsuccessful transmission. The transmission from the device will proceed as requested, as the device will always take collision precedence over the host.
5. After the device issues an R\_RDY primitive to the XRS10L140, the XRS10L140 will transmit the frame from the host to the device. The XRS10L140 will not send an R\_OK status primitive to the host until the device has issued an R\_OK primitive to indicate successful frame reception. In this way, the R\_OK status handshake is interlocked from the device to the host.

If an error is detected during any part of the frame transfer, the XRS10L140 will ensure that the error condition is propagated to the host and the device. If no error occurs during frame transfer, the XRS10L140 will not alter the contents of the frame, or modify the CRC in any way.

**3.4.2 Transmission from a device to a host**

A device indicates a transmit to a host in the same way as would be done if the host and device were attached directly. This transaction obeys the following procedure:



1. After receiving an X\_RDY primitive from the device, the XRS10L140 will determine if the X bit is set in the device port's PSCR[1] (SError) register. The XRS10L140 will not issue an R\_RDY primitive to the device until this bit is cleared to zero.
2. The XRS10L140 will then receive the frame from the device. The XRS10L140 will fill in the PM Port field with the port address of the transmitting device. The XRS10L140 will then check the CRC received from the device, and if valid, it will recalculate the CRC based upon the new PM Port field. If the CRC calculated from the device is incorrect, the XRS10L140 will corrupt the CRC sent to the host to ensure propagation of the error condition
3. The XRS10L140 will issue an X\_RDY primitive to the host to start the transmission of the frame to the host. After the host issues an R\_RDY primitive to the XRS10L140, the frame from the device, with the updated CRC, will then be transmitted to the host. The XRS10L140 will not send an R\_OK status primitive to the device until the host has issued an R\_OK primitive to indicate successful frame reception. In this way, the R\_OK status handshake will be interlocked from the device to the host.

If an error is detected during any part of the frame transfer, the XRS10L140 will ensure that the error condition is propagated to the host and the device.

### 3.5 Clocking

The XRS10L140 allows the use of either an external reference clock or of a low cost crystal oscillator to act as a reference clock. Separate device inputs are available for each approach, with full rate reference clock inputs provided on pins CMU\_REFP and CMU\_REFN, and crystal oscillator inputs provided on pins XOD and XOG. Supported data rates and their appropriate PLL divide factors are outlined in [Table 2](#).

TABLE 2: PLL DIVIDE FACTORS

MODE	SYSCLK	/REF	/FB	DINCLK RXCLK	SERIAL CLOCK	DATA RATE
SATA Gen. 1	25MHz	1	30	150MHz	750MHz	1.5Gbps*
SATA Gen. 1	75MHz	1	10	150MHz	750MHz	1.5Gbps*
SATA Gen. 1	100MHz	2	15	150MHz	750MHz	1.5Gbps*
SATA Gen. 1	150MHz	1	5	150MHz	750MHz	1.5Gbps*
SATA Gen. 2	25MHz	1	60	300MHz	1.5GHz	3.0Gbps
SATA Gen. 2	75MHz	1	20	300MHz	1.5GHz	3.0Gbps
SATA Gen. 2	100MHz	2	30	300MHz	1.5GHz	3.0Gbps
SATA Gen. 2	150MHz	1	10	300MHz	1.5GHz	3.0Gbps

**NOTE:** \* All link start with 3.0Gbps, then negotiate down to 1.5Gbps for SATA Generation 1 devices.

#### 3.5.1 Spread Spectrum Clocking

The XRS10L140 provides full support for receipt and generation of signals that have been configured for Spread Spectrum Clocking (SSC) support. The spread technique is implemented by down-spreading the data rate by 0.5% as a means of reducing EMI. Generation of the down-spread clock is performed within the XRS10L140. An example of the resultant spectral fundamental frequency before and after SSC can be seen in [Figure 9](#).

FIGURE 9. SPREAD SPECTRUM CLOCKING

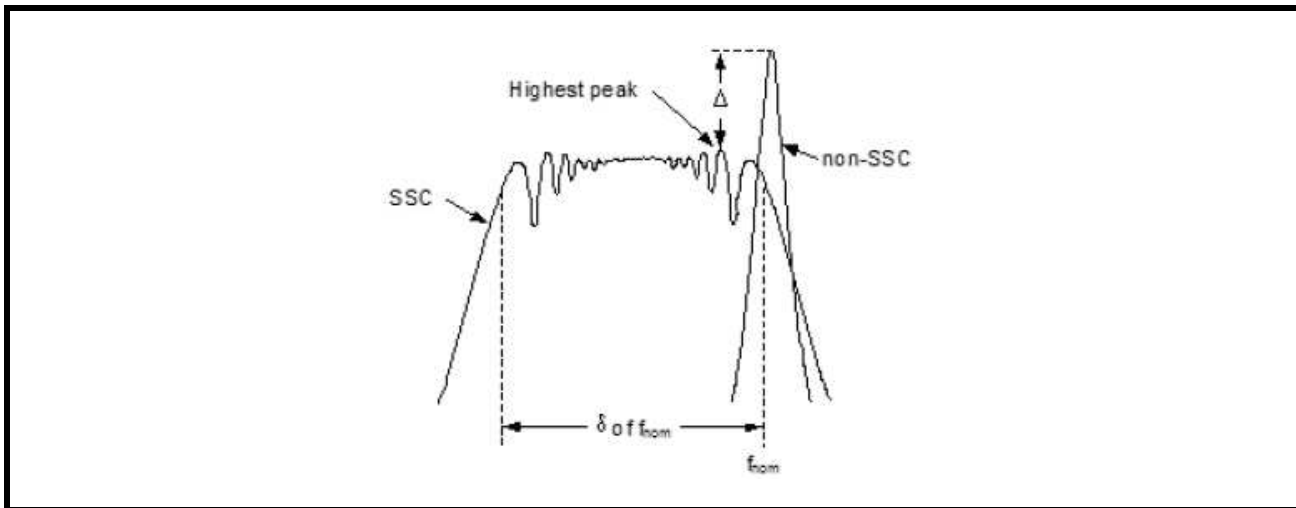

## 4.0 ELECTRICAL SPECIFICATIONS

This section contains the electrical specifications for the XRS10L140.

### 4.1 Serial ATA Specifications

The XRS10L140 electrical transmit and receive specifications are outlined in this section. The XRS10L140 is fully compliant to the Serial ATA II specification for Gen2i, Gen2x, Gen2m, Gen1i, Gen1x and Gen1m variations at 3.0 and 1.5 Gbps.

#### 4.1.1 Serial ATA Transmitter

A simplified version of the output circuit and test fixture for each of the 5 Serial ATA transmit outputs on the XRS10L140 is shown in **Figure 10**. The output differential pair is terminated to the supply VDD. The circuit is designed to be AC coupled.

**FIGURE 10. SERIAL ATA EQUIVALENT OUTPUT CIRCUIT**

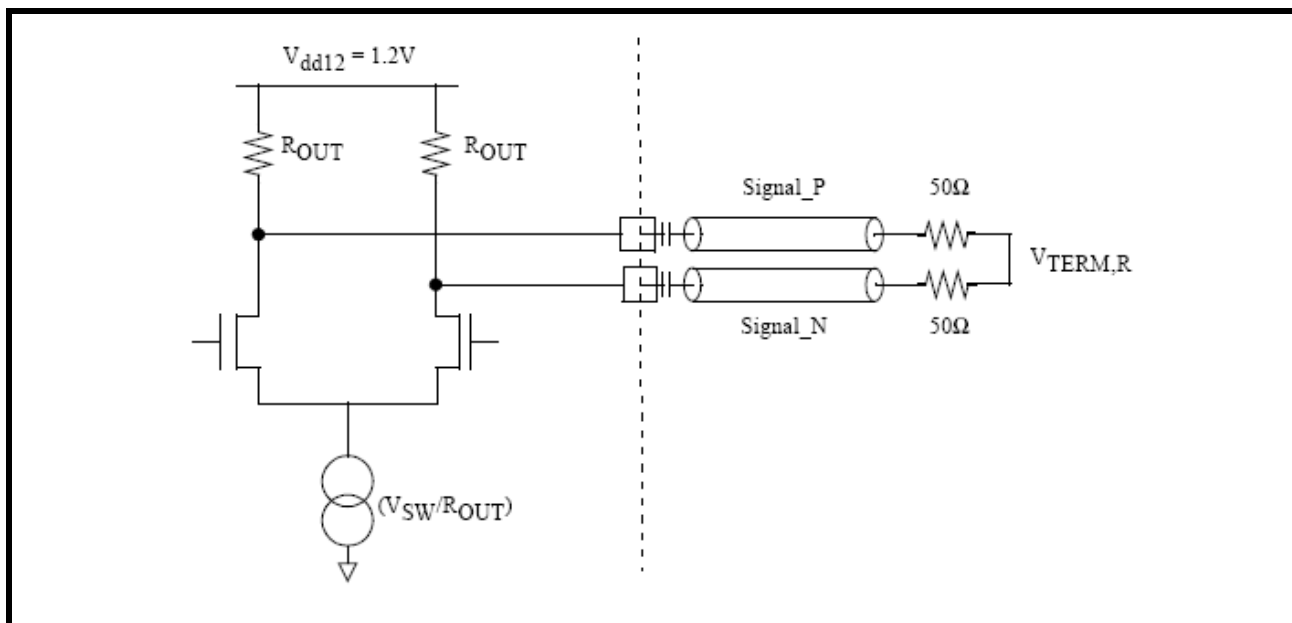

The XRS10L140 Serial ATA outputs include a simple one-tap equalizer, that is useful in driving longer printed circuit traces and is a required component in second generation Serial ATA PHYs. This equalizer pre-emphasizes the output signal whenever there is a data transition. The amount of pre-emphasis can vary between 0 and 45.5%, and is configured via MDIO register settings. Note that pre-emphasis doesn't increase the overall swing, but instead reduces the output amplitude when there is no transition.

FIGURE 11. EFFECTS OF TRANSMIT PRE-EMPHASIS

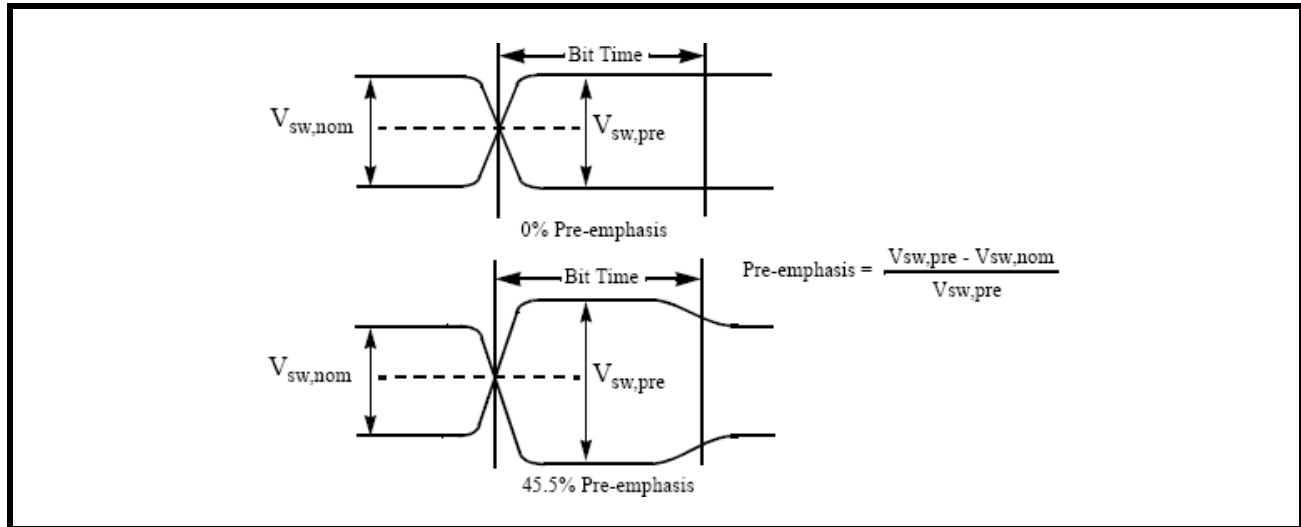

The overall swing level can also be modified via MDIO register settings. The XRS10L140 transmit mask is shown in [Figure 12](#).

FIGURE 12. TRANSMIT EYE MASK FOR SERIAL ATA OUTPUT

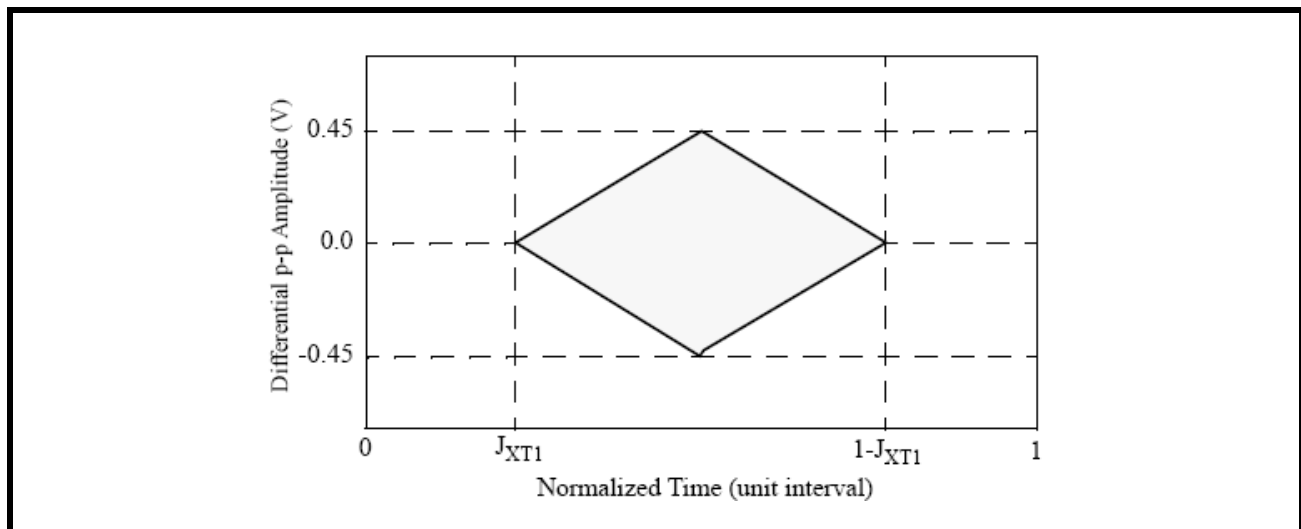

4.1.2 Serial ATA Receiver

An equivalent circuit for the XRS10L140 Serial ATA inputs is shown in **Figure 13**. The device receiver mask is shown in **Figure 14**. This circuit is designed to be AC coupled. The termination resistors are not connected during power-up

FIGURE 13. SERIAL ATA EQUIVALENT INPUT CIRCUIT

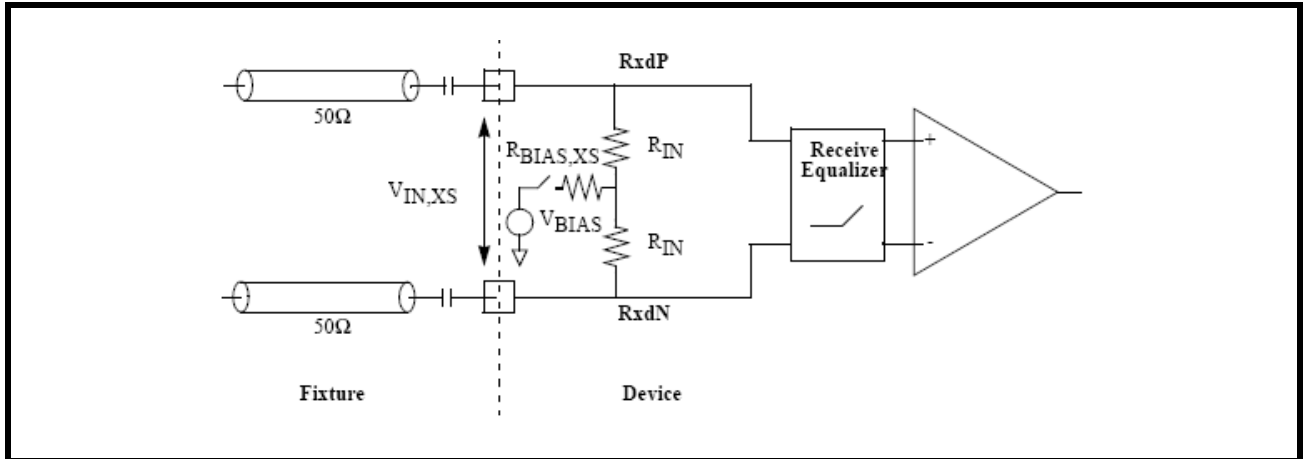

FIGURE 14. RECEIVE EYE MASK FOR SERIAL ATA INPUT

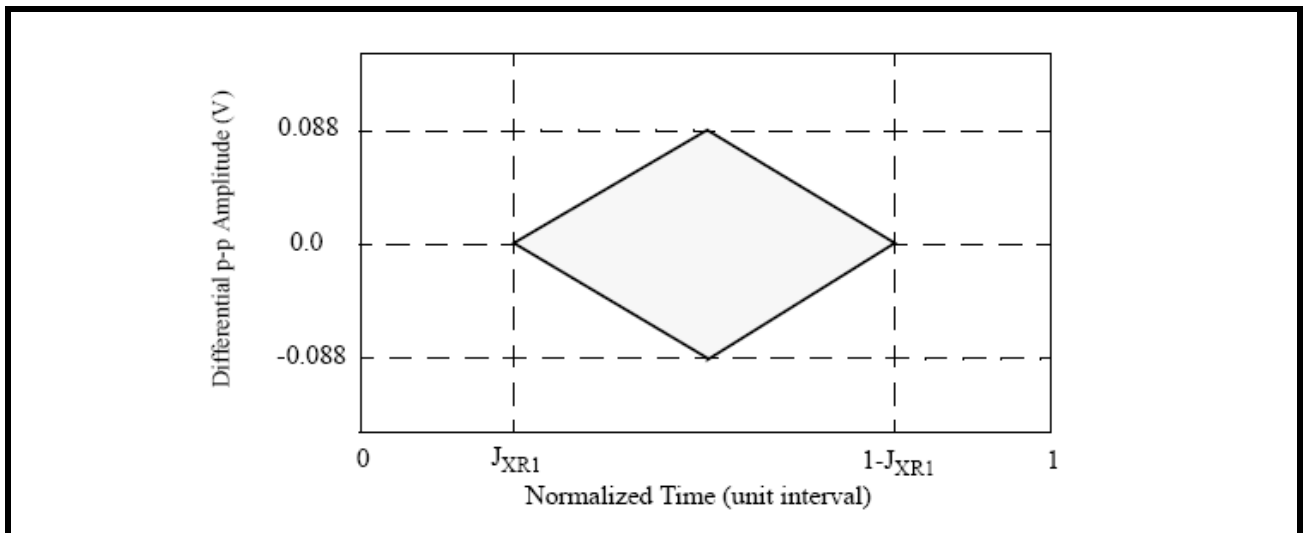

TABLE 3: SERIAL ATA LINK SPECIFICATIONS

NAME	DESCRIPTION	MIN.	NOM	MAX	UNITS
$t_{BIT,XS}$	Bit Time	670	-	333	ps
$J_{XR1}$	Input Jitter Tolerance Mask at signal crossover	0.32	-	-	UI
$J_{XR1,DJ}$	Deterministic jitter tolerance at signal crossover	0.18	-	-	UI
$J_{XT1}$	Output jitter mask at signal crossover	-	-	0.15	UI
$J_{XT1,DJ}$	Deterministic output jitter at signal crossover	-	-	0.07	UI
$t_R/t_F$	Input signal rise/fall times (20% - 80%)	0.2	-	0.46	UI
$t_{QR}/t_{QF}$	Output signal rise/fall times (20% - 80%)	0.2	-	0.41	UI
$t_{TOL,RX}^1$	RX to sysclock frequency offset tolerance	-5350	0	350	ppm
$V_{IN}$	Input swing, differential peak-peak	175	-	1600	mV
$V_{SW}^2$	Output swing, differential peak-peak	800	-	1200	mV
$V_{IN,IDLE}$	No swing detection threshold	65	120	155	mV
$R_{IN,DIFF}$	Differential mode input resistance	85	100	115	$\Omega$
$R_{IN,CM}^3$	Common mode input resistance	40	50	60	$\Omega$
$R_{IN,OFF}$	Common mode input resistance, no power	200	-	-	k $\Omega$
$R_{IN,XS}$	Output termination resistance	40	50	60	$\Omega$
$S_{11,IN,DIFF}$	Differential input return loss, 50MHz - 1.5GHz	12	-	-	dB
$S_{11,IN,CM}$	Common mode input return loss 50MHz-1.5GHz	6	-	-	dB
$S_{22,OUT,DIFF}$	Differential output return loss 50MHz-1.5GHz	12	-	-	dB
$S_{22,OUT,CM}$	Common mode output return loss 50MHz-1.5GHz	6	-	-	dB
$t_{S,REG}$	Setup time for register port	1.5	-	-	ns
$t_{H,REG}$	Hold time for register port	1.5	-	-	ns
$t_{Q,REG}$	Clock to Q time for register port	0	-	2	ns
$t_{CYC,REG}$	Register port clock cycle time	10	-	-	ns
$t_{HI,REG}$	R register port clock high time	4	-	-	ns
$t_{LO,REG}$	Register port clock low time	4	-	-	ns
$t_{RF,REG}$	Register port input rise/fall time	-	-	0.5	ns

**NOTES:**

1. This value includes 0.5% downspread Spread Spectrum clocking, plus 350ppm tolerance around the center frequency.
2. This is measured at the package ball and does not include any board or connector loss.
3. This value can be as low as 5 $\Omega$  during power on.

#### 4.2 CMOS Interface

AC and DC specifications for the CMOS inputs and outputs are listed in **Table 4**. Since all these signals are asynchronous, there are no setup or hold times defined. The CMOS pins are defined in the General Control and Configuration portion of **Table 1** in Section 3, "Pin Descriptions".

**TABLE 4: CMOS I/O SPECIFICATIONS**

NAME	DESCRIPTION	MIN	NOM	MAX	UNITS
$t_{DR}/t_{DF,CMOS}$	CMOS input signal rise/fall times (20% - 80%)	0.2	-	5	ns
$t_{QR}/t_{QF,CMOS}^1$	CMOS output signal rise/fall times (20% - 80%)	0.2	-	5	ns
$V_{IL,CMOS}$	CMOS input low voltage	-0.3	0	0.8	V
$V_{IH,CMOS}$	CMOS input high voltage	1.7	3.3	3.6	V
$V_{OL,CMOS}$	CMOS output low voltage	-0.3	0	0.4	V
$V_{PULLUP}$	Open Drain Pull-up Voltage	2.3		3.6	V
$I_{OL,CMOS}$	Output current for VOL = 0.4V	10	-	20	mA
$dl_{OL}/dt_{,CMOS}$	Output current rate of change	-10	-	10	mA/ns
$L_{I,CMOS}$	CMOS I/O inductance	-	-	8	nH
$C_{I,CMOS}$	CMOS I/O capacitance	-	-	5	pF
$I_{LEAKAGE}^2$	CMOS I/O Leakage Current			150	uA

**NOTE:** .1. This value is measured driving a load of 20pF.

**NOTE:** .2. This values is measured at 2.5 VDC.

#### 4.3 MDIO Interface

The Management Data Input/Output (MDIO) port complies with Clause 45 of the IEEE 802.3ae specification. A representative MDIO driver/receiver is shown in **Figure 15**. MDIO uses an open drain driver with a pullup resistor.

FIGURE 15. REPRESENTATIVE MDIO CIRCUIT

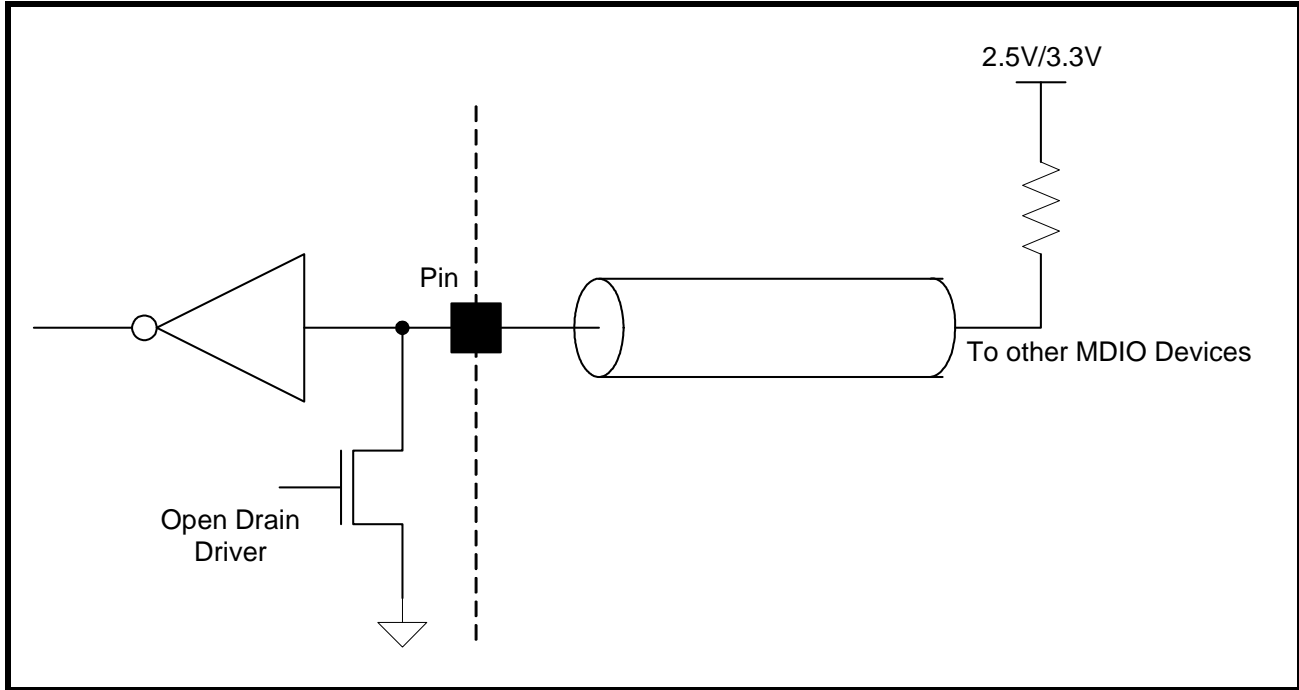

Representative MDIO Read and Write waveforms are shown in [Figure 16](#). The XRS10L140 samples MDIO on the rising edge of MDC for input and drives MDIO after the rising edge of MDC for output. Note that setup, hold, and output timings are defined from the maximum  $V_{IL}$  and minimum  $V_{IH}$  levels.

FIGURE 16. MDIO INPUT AND OUTPUT WAVEFORMS

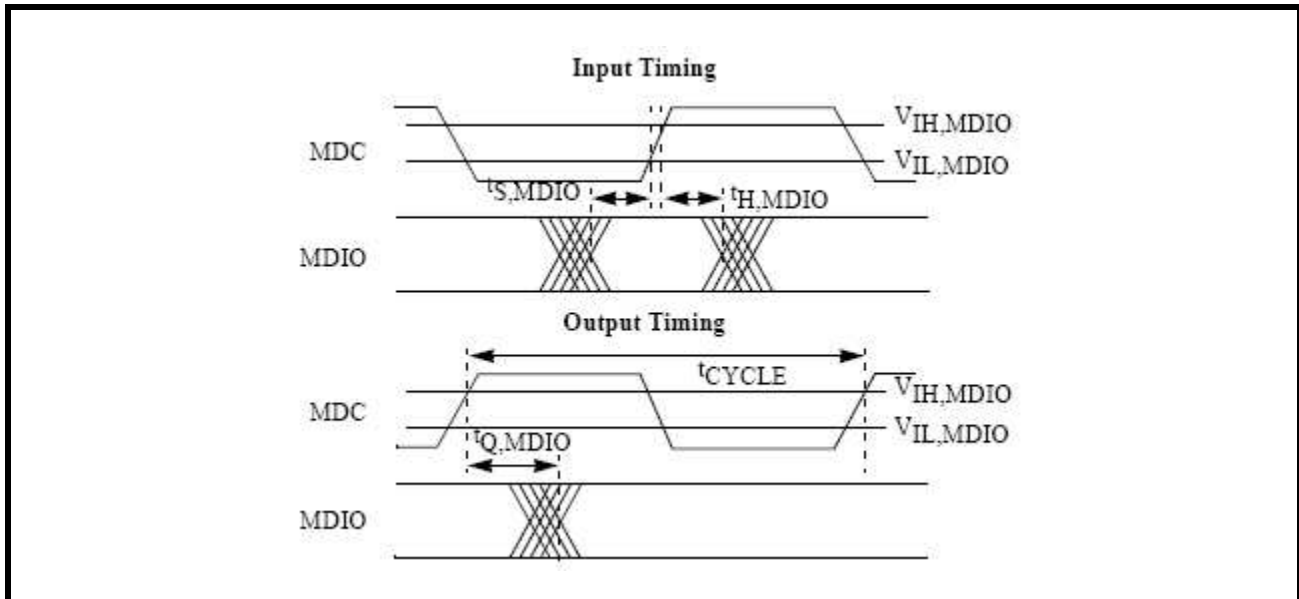

Values for MDIO parameters are shown in [Table 5](#)

**TABLE 5: MDIO DC AND AC CHARACTERISTICS**

NAME	DESCRIPTION	MIN	NOM	MAX	UNITS
$t_{\text{CYCLE,MDIO}}$	MDC cycle time	400	-	-	ns
$t_{\text{LOW,MDC}}$	MDC low time	160	-	-	ns
$t_{\text{HIGH,MDC}}$	MDC high time	160	-	-	ns
$t_{\text{S,MDIO}}^1$	MDIO input to MDC setup time	10	-	-	ns
$t_{\text{H,MDIO}}^2$	MDC to MDIO input hold time	10	-	-	ns
$t_{\text{Q,MDIO}}^3$	MDC to MDIO output time	0	-	150	ns
$t_{\text{DR}}/t_{\text{DF,MDIO}}$	MDIO input signal rise/fall times (20% - 80%)	0.2	-	100	ns
$t_{\text{QR}}/t_{\text{QF,MDIO}}^4$	MDIO output signal rise/fall times (20% - 80%)	0.2	-	80	ns
$V_{\text{IL,MDIO}}$	MDIO input low voltage	-0.3	0	0.8	V
$V_{\text{IH,MDIO}}$	MDIO input high voltage	1.7	3.3	3.6	V
$V_{\text{OL,MDIO}}^4$	MDIO output low voltage	-0.3	0	0.4	V
$V_{\text{PULLUP}}$	Open Drain Pull-up Voltage	2.3	-	3.6	V
$I_{\text{OL,MDIO}}$	MDIO Output current for $V_{\text{OL}} = 0.4\text{V}$	10	-	20	mA
$di_{\text{OL}}/dt_{\text{MDIO}}$	MDIO Output current rate of change	-10	-	10	mA/ns
$L_{\text{I,MDIO}}$	MDIO input inductance	-	-	8	nH
$C_{\text{I,MDIO}}$	MDIO input capacitance	-	-	5	pF

**NOTES:**

- Measured from minimum MDIO  $V_{\text{IH}}$  to maximum MDC  $V_{\text{IL}}$  for MDIO rising edge.  
 Measured from maximum MDIO  $V_{\text{IL}}$  to maximum MDC  $V_{\text{IL}}$  for MDIO falling edge.
- Measured from minimum MDC  $V_{\text{IH}}$  to maximum MDIO  $V_{\text{IL}}$  for MDIO rising edge.  
 Measured from minimum MDC  $V_{\text{IH}}$  to minimum MDIO  $V_{\text{IH}}$  for MDIO falling edge.
- Measured from minimum MDC  $V_{\text{IH}}$  to maximum MDIO  $V_{\text{IL}}$  for MDIO rising edge and MDC rising edge.  
 Measured from minimum MDC  $V_{\text{IH}}$  to minimum MDIO  $V_{\text{IH}}$  for MDIO falling edge and MDC rising edge.  
 Measured from maximum MDC  $V_{\text{IL}}$  to maximum MDIO  $V_{\text{IL}}$  for MDIO rising edge and MDC falling edge.  
 Measured from maximum MDC  $V_{\text{IL}}$  to minimum MDIO  $V_{\text{IH}}$  for MDIO falling edge and MDC falling edge.
- Measured driving a load of 470pF.

**TABLE 6: OPERATING CONDITIONS**

Name	Description	Min	Nom	Max	Units
$T_{\text{A}}$	Ambient temperature under bias	-40	25	85	°C
$V_{\text{DD}}$	Core power supply voltage	1.14	1.2	1.26	V
$I_{\text{DD}}$	Core power supply current	-	460	600	mA

TABLE 6: OPERATING CONDITIONS

Name	Description	Min	Nom	Max	Units
V <sub>ESD1</sub>	Electrostatic discharge tolerance, Human Body Model - Any pin with respect to any other pin except VDDA pins (pins 14, 34, 45, 50, 62, and 87)	-2000		2000	V
V <sub>ESD2</sub>	Electrostatic discharge tolerance, Human Body Model - Any pin with respect to VDDA pins (pins 14, 34, 45, 50, 62, and 87)	-500		500	V
θ <sub>JA</sub>	Junction-to-ambient thermal resistance		38.5		°C/W

## 5.0 REGISTERS DESCRIPTION

The XRS10L140 provides a variety of registers for the purpose of device configuration, testing and monitoring. These registers are accessed through the MDIO interface, outlined in **“Section 4.3, MDIO Interface” on page 17**. Operational registers available to the customer are given below. Note that all other address space should be left unmodified in order to ensure proper behaviour of the device.

### 5.1 Register Overview

The XRS10L140 port address is hardwired to 0; this field should be set to 0 in all packets. The XRS10L140 contains three identical instantiations of a dual Serial ATA PHY macro. A common set of registers exists within each of these macros, and are outlined in **“Section 5.2, Macro Registers” on page 22**. MDIO device designations 1-3 are used for each of these three macros as shown in **Table 7**. Registers relating to the XRS10L140 as a whole are outlined in **“Section 5.3, XRS10L140 Device Generic Registers” on page 27** and make use of MDIO device 0.

**TABLE 7: MDIO DEVICE DESIGNATIONS**

MDIO DEVICE DESIGNATION	MACRO	RELEVANT PINS
0	XRS10L140 Device Generic Registers	N/A
1	Serial ATA Input Macro	SI
2	Serial ATA Output Macro 0	SO0, SO1
3	Serial ATA Output Macro 1	SO2, SO3

The XRS10L140 registers are arranged as 8-bit fields with 8-bit addresses. These are mapped into the 16-bit MDIO address and data fields by setting the most significant byte of each to be 0. An example mapping from a macro address/data combination to an MDIO address & data combination is shown in **Table 8**.

**TABLE 8: MDIO ADDRESSING**

MACRO ADDRESS	MACRO DATA	MDIO ADDRESS	MDIO DATA
0x40	abcde	0x0040	0000000000abcde

**NOTE:** The unused upper 3 bits in FBDIV are also set to 0 during MDIO writes and are undefined during MDIO reads.

In the description of each register field, there is an entry describing its read/write status. This may fall into one of the following categories:

- RW- register field is read/write
- RO - register field is read only
- LL - Latching Low - Used with bits that monitor some state internal to the XRS10L140. When the condition for the bit to go low is reached, the bit stays low until the next time it is read. Once it is read, its value reverts to the current state of the condition it monitors.
- LH - Latching High - When the condition for the bit to go high is reached, the bit stays high until the next time it is read. Once it is read, its value reverts to the current state of the condition it monitors.
- SC - When an SC bit is set, some action is initiated; once the action is complete, the bit is cleared.

**5.2 Macro Registers**

The registers outlined in this section are common to each of the three Serial ATA dual PHY macros as described in the previous section. As such, each listed register is present in each of the 1, 2, and 3 MDIO register spaces, and will perform the stated function on the specified Serial ATA lane.

The registers within each dual PHY macro are split into the following sections:

Transmit/Receive lane 0 registers:	Address range 000*****
Transmit/Receive lane 1 registers:	Address range 001*****
PLL registers:	Address range 010*****
Bias generator registers:	Address range 011*****

**TABLE 9: TRANSMIT/RECEIVE LANE REGISTERS (MDIO DEVICE 1, 2, 3)**

ADDRESS HEX	BIT(S)	NAME	RW	DEFAULT	DESCRIPTION
N.0000 N.0020	7	Reserved	RW	0	DO NOT MODIFY
	6	SATAPCIEXB_G1	RW	0	Tx output swing booster bit (Gen 1) 0 = boost swing by 15% 1 = nominal swing
	5:1	Reserved	RW	0001	DO NOT MODIFY
	0	SATAPCIEXB_G2	RW	0	Tx output swing booster bit (Gen 2) 0 = boost swing by 15% 1 = nominal swing
N.0001 N.0021	7:3 7:3	Reserved	RW	00000	DO NOT MODIFY
	2:0	Transmit_Eq0[2:0] Transmit_Eq1[2:0]	RW	011	Transmit pre-emphasis control 000 = 0% transmit preemphasis 001 = 6.5% transmit preemphasis 010 = 13% transmit preemphasis 011 = 19.5% transmit preemphasis 100 = 26% transmit preemphasis 101 = 32.5% transmit preemphasis 110 = 39% transmit preemphasis 111 = 45.5% transmit preemphasis

**TABLE 9: TRANSMIT/RECEIVE LANE REGISTERS (MDIO DEVICE 1, 2, 3)**

ADDRESS HEX	BIT(S)	NAME	RW	DEFAULT	DESCRIPTION
N.0002 N.0022	7:6 7:6	mScProg0[1:0] mScProg1[1:0]	RW	10	Receive equalization control – boost at 1.5GHz *(Note mScProg = '10' default for device Revision E, mScProg = '01' default for device Revision D)
	5:3 5:3	Beacon_Swing0[2:0] Beacon_Swing1[2:0]	RW	100	Transmit swing size for OOB Signals 000 = 800mV 001 = 700mV 010 = 600mV 011 = 500mV 100 = 400mV 101 = 300mV 110 = 200mV 111 = 0mV
	2:0 2:0	Output_Swing0[2:0] Output_Swing1[2:0]	RW	100	Transmit swing size in normal operation 000 = 800mV 001 = 700mV 010 = 600mV 011 = 500mV 100 = 400mV 101 = 300mV 110 = 200mV 111 = 0mV
N.0003 N.0023	7	enEqB	RW	0	Enable receive equalization 0 = enable equalization 1 = disable equalization
	6:0	Reserved	RW	0010000	DO NOT MODIFY
N.0015 N.0035	7	Reserved	RO	-	Reserved
	6:4	sysclk25divsel0[2:0] sysclk25divsel1[2:0]	RW	000	Divider selection for sysclk-> sysclk25 000 = divide by 1 (sysclk is 25MHz) 001 = divide by 2 (sysclk is 50MHz) 010 = divide by 3 (sysclk is 75MHz) 011 = divide by 4 (sysclk is 100MHz) 100 = divide by 5 (sysclk is 125MHz) 101 = divide by 6 (sysclk is 150MHz) 110 = divide by 10 (sysclk is 250MHz) 111 = divide by 12 (sysclk is 300MHz)
	3:0	Reserved	RW	0x5	DO NOT MODIFY

TABLE 9: TRANSMIT/RECEIVE LANE REGISTERS (MDIO DEVICE 1, 2, 3)

ADDRESS HEX	BIT(S)	NAME	RW	DEFAULT	DESCRIPTION
N.0018	7:3	Reserved	RWRO	00100	DO NOT MODIFY
N.0038	2:0	txbiasbuffsela0[2:0] txbiasbuffsela1[2:0]	RW	100	Tx Predriver swing size in normal operation 000 = 800mV 001 = 700mV 010 = 600mV 011 = 500mV 100 = 400mV (sata default) 101 = 300mV

**TABLE 10: PLL CONFIGURATION REGISTERS (MDIO DEVICE 1, 2, 3)**

ADDRESS HEX	BIT(S)	NAME	TYPE	DEFAULT	DESCRIPTION
N.0040	7:6	Reserved	RO	-	Reserved
	5:0	FBDIV[5:0]	RW	101101	Divide value for feedback clock 110000 = divide by 5 100000 = divide by 10 100001 = divide by 15 100010 = divide by 20 100011 = divide by 25 100101 = divide by 30 100111 = divide by 50 101101 = divide by 60 (default for 25MHz Ref) Other - reserved
N.0041	7:6	Reserved	RO	-	Reserved
	5:0	REFDIV[5:0]	RW	010000	Divide values for system clock 010000 = divide by 1 (default for 25MHz Ref) 000000 = divide by 2 000001 = divide by 3 000010 = divide by 4 000011 = divide by 5 000101 = divide by 6 000110 = divide by 8 000111 = divide by 10 001101 = divide by 12 001110 = divide by 16 001111 = divide by 20 Others - reserved
N.0044	7:6	Reserved	RO	-	Reserved
	5:0	SSCMax	RW	00000	Maximum value for spread (set to 45, [0x2D] when SSC is set to "0")
N.0045 NOTE 1	7:5	Reserved	RO	-	Reserved
	4	SSCmode	RW	0	Selects position of spreading interpolator 0 = Interpolator in feedback path 1 = Interpolator in feedforward path
	3	Reserved	RW	0	DO NOT MODIFY
	2	SSCInvert	RW	0	Spread up instead of down
	1	Reserved	RW	0	DO NOT MODIFY
	0	SSCBypass	RW	1	Bypass the saw generator and pulse density modulator and get increment from SSCMax (set SSCMax to 45 when SSCBypass is set to 0)

**NOTE:** 1) In order to enable SSC generation, set register N.0044 to 0x2D, N.0045 to 0x14 and then reset the PLL by writing register 0.0004 to 0x0 then 0xF.

TABLE 11: BIAS GENERATOR CONFIGURATION REGISTERS (MDIO DEVICE 1, 2, 3)

ADDRESS HEX	BIT(S)	NAME	TYPE	RESET VALUE	DESCRIPTION
N.0064	7:4	pr100Tx[3:0]	RW	0x0	Transmit pre-driver current bias 1010=50uA 0010=75uA 0000=100uA 0001=125uA 1100=150uA 0111=175uA 1111=200uA
	3:0	Reserved	RW	0x0	DO NOT MODIFY
N.0065	7:4	Reserved	RW	0x0	DO NOT MODIFY
	3:0	prcal100Tx[3:0]	RW	0x0	Transmit driver current bias 1010=50uA 0010=75uA 0000=100uA 0001=125uA 1100=150uA 0111=175uA 1111=200uA

TABLE 12: POWERDOWN REGISTERS (MDIO DEVICES 1, 2 &amp; 3)

ADDRESS HEX	BIT(S)	NAME	TYPE	RESET VALUE	DESCRIPTION
1.0080 2.0080 3.0080	7:6	SlpwrnDetB[1:0] SO01pwrnDetB[1:0] SO23pwrnDetB[1:0]	RW	11	Powers down the signal detector and COM* circuits 1 = normal operation 0 = power down
	5:4	SlpwrnRxB[1:0] SO01pwrnRxB[1:0] SO23pwrnRxB[1:0]	RW	11	Powers down the receivers and CDR 1 = normal operation 0 = power down
	3:2	SlpwrnTxDrvB[1:0] SO01pwrnTxDrvB[1:0] SO23pwrnTxDrvB[1:0]	RW	11	Powers down the transmitter 1 = normal operation 0 = power down
	1:0	SlpwrnTxB[1:0] SO01pwrnTxB[1:0] SO23pwrnTxB[1:0]	RW	11	Powers down the transmit pipes and clock 1 = normal operation 0 = power down

**TABLE 12: POWERDOWN REGISTERS (MDIO DEVICES 1, 2 & 3)**

ADDRESS HEX	BIT(S)	NAME	TYPE	RESET VALUE	DESCRIPTION
1.0081	7:2	Reserved	RO	-	Reserved
2.0081 3.0081	1	SlpwrnBiasGen SO01pwrnBiasGen SO23pwrnBiasGen	RW	0	Powers down the bandgap. 1 = power down 0 = normal operation
	0	SlpwrnPLLB SO01pwrnPLLB SO23pwrnPLLB	RW	1	Powers down the PLL 1 = normal operation 0 = power down

### 5.3 XRS10L140 Device Generic Registers

This section outlines generic registers relating to the XRS10L140 as a whole. These registers are accessed through MDIO device 0.

**TABLE 13: RESET CONTROL SIGNALS**

ADDRESS HEX	BIT(S)	NAME	TYPE	RESET VALUE	DESCRIPTION
0.0030	7:0	revision_id[7:0]	R/O	05H	*(Note 1) Device Revision ID
0.0031	7:0	device_id [15:8]	R/O	83H	Device ID MSB
0.0032	7:0	device_id [7:0]	R/O	06H	Device ID LSB

**NOTE:** 1) Revision ID 05H is for device Revision E. Revision ID 03H is for device Revision D.

**TABLE 14: CLOCK CONFIGURATION REGISTER**

ADDRESS HEX	BIT(S)	NAME	TYPE	RESET VALUE	DESCRIPTION
0.0001	7:3	Reserved	RO	-	Reserved
	2	refClkSel	RW	0	1 = select CMU_REF 0 = select on chip crystal oscillator
	1:0	Reserved	RW	00	DO NOT MODIFY

**TABLE 15: PORT MULTIPLIER SATA STANDARD REGISTERS**

REGISTER	BIT(S)	NAME	TYPE	DEFAULT VALUE	DESCRIPTION
GSCR(0) Product Identifier	31 - 16	Device ID	R/O	0x8306	Device ID allocated by the vendor.
	15 - 0	Vendor ID	R/O	0x13A8	Vendor ID allocated by the PCI-SIG of the vendor that produced the Port Multiplier.

TABLE 15: PORT MULTIPLIER SATA STANDARD REGISTERS

REGISTER	BIT(S)	NAME	TYPE	DEFAULT VALUE	DESCRIPTION
GSCR(1) Revision Information	31 - 16	Reserved	R/O	0x0000	31-16 Reserved
	15 - 8	REV_LEV	R/O	0x03	15-8 Revision level of the Port Multiplier.
	7:4	Reserved	R/O	0x0	7-4 Reserved
	3	PM_1,2	R/O	1	1=Supports Port Multiplier specification 1.2.
	2	PM_1.1	R/O	1	1=Supports Port Multiplier specification 1.1.
	1	PM_1.0	R/O	1	1=Supports Port Multiplier specification 1.0.
	0	Reserved	R/O	0	Reserved
GSCR(2) Port Information	7:4	Reserved	R/O	0x0	Reserved
	3 - 0	DEV_FAN_OUT_PORTS	R/O	0x4	Number of exposed device fan-out ports.
GSCR(32) Error Information	31 - 15	Reserved	R/O	0x0	
	14	OR_PORT-14	R/O	0x0	OR of selectable bits in Port 14 PSCR[1] (SError)
	13	OR_PORT-13	R/O		OR of selectable bits in Port 13 PSCR[1] (SError)
	12	OR_PORT-12	R/O		OR of selectable bits in Port 12 PSCR[1] (SError)
	11	OR_PORT-11	R/O		OR of selectable bits in Port 11 PSCR[1] (SError)
	10	OR_PORT-10	R/O		OR of selectable bits in Port 10 PSCR[1] (SError)
	9	OR_PORT-9	R/O		OR of selectable bits in Port 9 PSCR[1] (SError)
	8	OR_PORT-8	R/O		OR of selectable bits in Port 8 PSCR[1] (SError)
	7	OR_PORT-7	R/O		OR of selectable bits in Port 7 PSCR[1] (SError)
	6	OR_PORT-6	R/O		OR of selectable bits in Port 6 PSCR[1] (SError)
	5	OR_PORT-5	R/O		OR of selectable bits in Port 5 PSCR[1] (SError)
	4	OR_PORT-4	R/O		OR of selectable bits in Port 4 PSCR[1] (SError)
	3	OR_PORT-3	R/O		OR of selectable bits in Port 3 PSCR[1] (SError)
	2	OR_PORT-2	R/O		OR of selectable bits in Port 2 PSCR[1] (SError)
	1	OR_PORT-1	R/O		OR of selectable bits in Port 1 PSCR[1] (SError)
0	OR_PORT-0	R/O		OR of selectable bits in Port 0 PSCR[1] (SError)	
GSCR(33) Error Information Bit Enable	31 - 0	ERR_INFO_EN	R/O	0x0	If set, bit is enabled for use in GSCR[32]



TABLE 15: PORT MULTIPLIER SATA STANDARD REGISTERS

REGISTER	BIT(S)	NAME	TYPE	DEFAULT VALUE	DESCRIPTION
GSCR(64) Port Multiplier Revision 1.X Features Support	31 - 5	Reserved	R/O	0x0	Reserved
	4	PHY_EVENT	R/O	0	1 = Supports Phy event counters
	3	ASYNC	R/O	1	1 = Supports asynchronous notification
	2	SSC	R/O	0	1 = Supports dynamic SSC transmit enable
	1	PMREQ <sub>p</sub>	R/O	1	1 = Supports issuing PMREQ <sub>p</sub> to host
	0	BIST	R/O	0	1 = Supports BIST
GSCR(96) Port Multiplier Revision 1.X Features Enable	31 - 4	Reserved	R/O	0x0	Reserved
	3	ASYNC_EN	RW	0	1 = Asynchronous notification enabled
	2	SSC_EN	RW	0	1 = Dynamic SSC transmit is enabled
	1	PMREQ <sub>p</sub> _EN	RW	0	1 = Issuing PMREQ <sub>p</sub> to host is enabled
	0	BIST_EN	RW	0	1 = BIST support is enabled

TABLE 16: SATA STANDARD REGISTERS - DEVICE PORT (0 TO 3) - STATUS AND CONTROL

**NOTE:** Registers designated as WC are write clear. In order to clear a particular bit or bit field within a WC designated register, write a '1' to that bit or bit field.

REGISTER	BIT(s)	NAME	TYPE	DEFAULT VALUE	DESCRIPTION
PSCR(0) (SStatus)	31 - 12	Reserved	R/O		Reserved
	11 - 8	IPM	R/O		The IPM value indicates the current interface power management state 0000b = Device not present or communication not established 0001b = Interface in active state 0010b = Interface in Partial power management state 0110b = Interface in Slumber power management state All other values reserved
	7 - 4	SPD	R/O		The SPD value indicates the negotiated interface communication speed established 0000b = No negotiated speed (device not present or communication not established) 0001b = Generation 1 communication rate negotiated 0010b = Generation 2 communication rate negotiated All other values reserved
	3 - 0	DET	R/O		The DET value indicates the interface device detection and Phy state. 0000b = No device detected and Phy communication not established 0001b = Device presence detected but Phy communication not established 0011b = Device presence detected and Phy communication established 0100b = Phy in offline mode as a result of the interface being disabled or running in a BIST loopback mode All other values reserved
PSCR(1) (SError)	31 - 16	DIAG	RWC		See description below
	15 - 0	ERR	RWC		See description below
PSCR(2) (SControl)	31 - 19	Reserved	R/O		Reserved All reserved fields shall be cleared to zero.
	20 - 16	PMP	RW		See description below
	15 - 12	SPM	RW		See description below
	11 - 8	IPM	RW		See description below
	7 - 4	SPD	RW		See description below
	3 - 0	DET	RW		See description below

**SError register SCR(1) -**

The Serial ATA interface Error register - SError - is a 32-bit register that conveys supplemental Interface error information to complement the error information available in the Shadow Register Block Error register. The register represents all the detected errors accumulated since the last time the SError register was cleared (whether recovered by the interface or not). Set bits in the error register are explicitly cleared by a write operation to the SError register, or a reset operation. The value written to clear set error bits shall have 1's encoded in the bit positions corresponding to the bits that are to be cleared. Host software should clear the Interface SError register at appropriate checkpoints in order to best isolate error conditions and the commands they impact.

**Bits [31:16] DIAG**

The DIAG field contains diagnostic error information for use by diagnostic software in validating correct operation or isolating failure modes. The field is bit significant as defined in the following figure.

<b>DIAG</b>	<b>R</b>	<b>R</b>	<b>R</b>	<b>R</b>	<b>A</b>	<b>X</b>	<b>F</b>	<b>T</b>	<b>S</b>	<b>H</b>	<b>C</b>	<b>D</b>	<b>B</b>	<b>W</b>	<b>I</b>	<b>N</b>
-------------	----------	----------	----------	----------	----------	----------	----------	----------	----------	----------	----------	----------	----------	----------	----------	----------

**A** Port Selector presence detected: This bit is set to one when COMWAKE is received while the host is in state HP2: HR\_AwaitCOMINIT. On power-up reset this bit is cleared to zero. The bit is cleared to zero when the host writes a one to this bit location.

**B** 10b to 8b Decode error: When set to a one, this bit indicates that one or more 10b to 8b decoding errors occurred since the bit was last cleared to zero.

**C** CRC Error: When set to one, this bit indicates that one or more CRC errors occurred with the Link layer since the bit was last cleared to zero.

**D** Disparity Error: When set to one, this bit indicates that incorrect disparity was detected one or more times since the last time the bit was cleared to zero.

**F** Unrecognized FIS type: When set to one, this bit indicates that since the bit was last cleared one or more FISes were received by the Transport layer with good CRC, but had atype field that was not recognized.

**I** Phy Internal Error: When set to one, this bit indicates that the Phy detected some internal error since the last time this bit was cleared to zero.

**N** PHYRDY change: When set to one, this bit indicates that the PHYRDY signal changed state since the last time this bit was cleared to zero.

**H** Handshake error: When set to one, this bit indicates that one or more R\_ERRPhandshake response was received in response to frame transmission. Such errors may be the result of a CRC error detected by the recipient, a disparity or 10b/8b decoding error, or other error condition leading to a negative handshake on a transmitted frame.

**R** Reserved bit for future use: Shall be cleared to zero.

**S** Link Sequence Error: When set to one, this bit indicates that one or more Link state machine error conditions was encountered since the last time this bit was cleared to zero. The Link layer state machine defines the conditions under which the link layer detects an erroneous transition.

**T** Transport state transition error: When set to one, this bit indicates that an error has occurred in the transition from one state to another within the Transport layer since the last time this bit was cleared to zero.

**W** COMWAKE Detected: When set to one this bit indicates that a COMWAKE signal was detected by the Phy since the last time this bit was cleared to zero.

**X** Exchanged: When set to one this bit indicates that device presence has changed since the last time this bit was cleared to zero. The means by which the implementation determines that the device presence has changed is vendor specific. This bit may be set to one anytime a Phy reset initialization sequence occurs as determined by reception of the COMINIT signal whether in response to a new device being inserted, in response to a COMRESET having been issued, or in response to power-up.

**Bits [15:0] ERR**

The ERR field contains error information for use by host software in determining the appropriate response to the error condition. The field is bit significant as defined in the following figure.

ERR	R	R	R	R	E	P	C	T	R	R	R	R	R	R	M	I
-----	---	---	---	---	---	---	---	---	---	---	---	---	---	---	---	---

**C** Non-recovered persistent communication or data integrity error: A communication error that was not recovered occurred that is expected to be persistent. Since the error condition is expected to be persistent the operation need not be retried by host software. Persistent communications errors may arise from faulty interconnect with the device, from a device that has been removed or has failed, or a number of other causes.

**E** Internal error: The host bus adapter experienced an internal error that caused the operation to fail and may have put the host bus adapter into an error state. Host software should reset the interface before re-trying the operation. If the condition persists, the host bus adapter may suffer from a design issue rendering it incompatible with the attached device.

**I** Recovered data integrity error: A data integrity error occurred that was recovered by the interface through a retry operation or other recovery action. This may arise from a noise burst in the transmission, a voltage supply variation, or from other causes. No action is required by host software since the operation ultimately succeeded, however, host software may elect to track such recovered errors in order to gauge overall communications integrity and potentially step down the negotiated communication speed.

**M** Recovered communications error: Communications between the device and host was temporarily lost but was re-established. This may arise from a device temporarily being removed, from a temporary loss of Phy synchronization, or from other causes and may be derived from the PHYRDYn signal between the Phy and Link layers. No action is required by the host software since the operation ultimately succeeded, however, host software may elect to track such recovered errors in order to gauge overall communications integrity and potentially step down the negotiated communication speed.

**P** Protocol error: A violation of the Serial ATA protocol was detected. This may arise from invalid or poorly formed FISes being received, from invalid state transitions, or from other causes. Host software should reset the interface and retry the corresponding operation. If such an error persists, the attached device may have a design issue rendering it incompatible with the host bus adapter.

**R** Reserved bit for future use: Shall be cleared to zero.

**T** Non-recovered transient data integrity error: A data integrity error occurred that was not recovered by the interface. Since the error condition is not expected to be persistent the operation should be retried by host software.

**SControl register SCR(2)**

The Serial ATA interface Control register - SControl - is a 32-bit read-write register that provides the interface by which software controls Serial ATA interface capabilities. Writes to the SControl register result in an action being taken by the host adapter or interface. Reads from the register return the last value written to it.

**Bits [19:16] PMP**

The Port Multiplier Port (PMP) field represents the 4-bit value to be placed in the PM Port field of all transmitted FISes. This field is '0000' upon power-up. This field is optional and an HBA implementation may choose to ignore this field if the FIS to be transmitted is constructed via an alternative method.

**Bits [15:12] SPM**

The Select Power Management (SPM) field is used to select a power management state. A non-zero value written to this field shall cause the power management state specified to be initiated. A value written to this field is treated as a one-shot. This field shall be read as 0000b.

- 0000b = No power management state transition requested

- 0001b = Transition to the Partial power management state initiated
- 0010b = Transition to the Slumber power management state initiated
- 0100b = Transition to the active power management state initiated
- All other values reserved

**Bits [11:8] IPM**

The IPM field represents the enabled interface power management states that may be invoked via the Serial ATA interface power management capabilities

- 0000b = No interface power management state restrictions
- 0001b = Transitions to the Partial power management state disabled
- 0010b = Transitions to the Slumber power management state disabled
- 0011b = Transitions to both the Partial and Slumber power management states disabled
- All other values reserved

**Bits [7:4]SPD**

The SPD field represents the highest allowed communication speed the interface is allowed to negotiate when interface communication speed is established

- 0000b = No speed negotiation restrictions
- 0001b = Limit speed negotiation to a rate not greater than Gen 1 communication rate
- 0010b = Limit speed negotiation to a rate not greater than Gen 2 communication rate
- All other values reserved

**Bits [3:0] DET**

The DET field controls the host adapter device detection and interface initialization.

- 0000b = No device detection or initialization action requested
- 0001b = Perform interface communication initialization sequence to establish communication. This is functionally equivalent to a hard reset and results in the interface being reset and communications reinitialized. Upon a write to the SControl register that sets the DET field to 0001b, the host interface shall transition to the HP1: HR\_Reset state and shall remain in that state until the DET field is set to a value other than 0001b, by a subsequent write to the SControl register.
- 0100b = Disable the Serial ATA interface and put Phy in offline mode.
- All other values reserved



**PRODUCT ORDERING INFORMATION**

PRODUCT NUMBER	PACKAGE TYPE	OPERATING TEMPERATURE RANGE
XRS10L140IV-F	100 Pin LQFP (Lead Free)	-40°C to +85°C
XRS10L140IV	100 Pin LQFP	-40°C to +85°C

## 100 LEAD LOW-PROFILE QUAD FLAT PACK

(14 x 14 x 1.4 mm LQFP, 1.0 mm FORM)

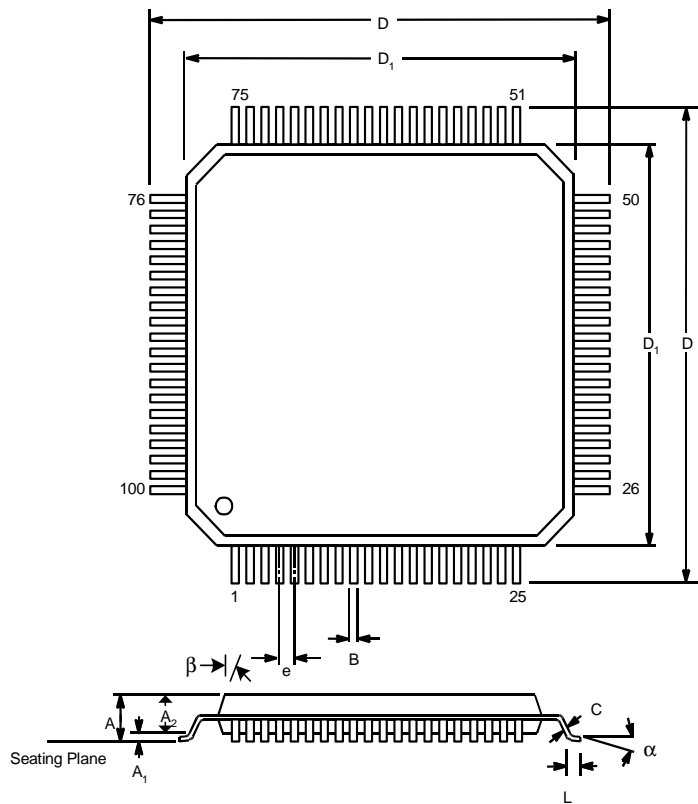
**NOTICE**

EXAR Corporation reserves the right to make changes to the products contained in this publication in order to improve design, performance or reliability. EXAR Corporation assumes no responsibility for the use of any circuits described herein, conveys no license under any patent or other right, and makes no representation that the circuits are free of patent infringement. Charts and schedules contained here in are only for illustration purposes and may vary depending upon a user's specific application. While the information in this publication has been carefully checked; no responsibility, however, is assumed for inaccuracies.

EXAR Corporation does not recommend the use of any of its products in life support applications where the failure or malfunction of the product can reasonably be expected to cause failure of the life support system or to significantly affect its safety or effectiveness. Products are not authorized for use in such applications unless EXAR Corporation receives, in writing, assurances to its satisfaction that: (a) the risk of injury or damage has been minimized; (b) the user assumes all such risks; (c) potential liability of EXAR Corporation is adequately protected under the circumstances.

Copyright 2008 EXAR Corporation

Datasheet January 2009.

Reproduction, in part or whole, without the prior written consent of EXAR Corporation is prohibited.

**NOTE:** The control dimension is in millimeters

SYMBOL	INCHES		MILLIMETERS	
	MIN	MAX	MIN	MAX
A	0.055	0.063	1.40	1.60
A <sub>1</sub>	0.002	0.006	0.05	0.15
A <sub>2</sub>	0.053	0.057	1.35	1.45
B	0.010	0.014	0.17	0.27
C	0.004	0.008	0.09	0.20
D	0.622	0.638	15.80	16.20
D <sub>1</sub>	0.390	0.555	13.90	14.10
e	0.0197 BSC		0.50 BSC	
L	0.018	0.030	0.45	0.75
α	0°	7°	0°	7°
β	7°typ		7°typ	

## REVISIONS

REV #	DATE	DESCRIPTION OF CHANGES
1.00	November 2007	Released.
1.01	January 2008	Corrected JTAG TRST, TDO pin desc., part ordering info.
1.02	February 2008	Revised to operational registers
1.03	May 2008	Corrected ESD tolerance to 2000V/500V ( <a href="#">Table 6</a> ) Added more description for " <a href="#">Section 3.2, Power Down Modes</a> " on page 9 - added reference to "XRS10L240/140 Errata"
1.04	August 2008	Removed references to link power management
1.05	January 2009	Chaged register default for Rx Equalization.