

**NOT RECOMMENDED
FOR NEW DESIGNS**
Use CMOS Technology

CD74FCT646

BiCMOS FCT Interface Logic, Octal Bus Transceiver/Register, Three-State

Features

- Buffered Inputs
- Typical Propagation Delay: 6.8ns at $V_{CC} = 5V$, $T_A = 25^\circ C$, $C_L = 50pF$
- Noninverting
- SCR Latchup Resistant BiCMOS Process and Circuit Design
- Speed of Bipolar FAST™/AS/S
- 64mA Output Sink Current
- Output Voltage Swing Limited to 3.7V at $V_{CC} = 5V$
- Controlled Output Edge Rates
- Input/Output Isolation to V_{CC}
- BiCMOS Technology with Low Quiescent Power

Ordering Information

PART NUMBER	TEMP. RANGE (°C)	PACKAGE	PKG. NO.
CD74FCT646EN	0 to 70	24 Ld PDIP	E24.3
CD74FCT646M	0 to 70	24 Ld SOIC	M24.3
CD74FCT646SM	0 to 70	24 Ld SSOP	M24.209

NOTE: When ordering the suffix M and SM packages, use the entire part number. Add the suffix 96 to obtain the variant in the tape and reel.

Description

The CD74FCT646 three-state octal bus transceiver/register uses a small geometry BiCMOS technology. The output stage is a combination of bipolar and CMOS transistors that limits the output HIGH level to two diode drops below V_{CC} . This resultant lowering of output swing (0V to 3.7V) reduces power bus ringing (a source of EMI) and minimizes V_{CC} bounce and ground bounce and their effects during simultaneous output switching. The output configuration also enhances switching speed and is capable of sinking 64 milliamperes.

This device is a bus transceiver with D-Type flip-flops which act as internal storage registers on the LOW to HIGH transition of either CAB or CBA clock inputs. Output Enable (\overline{OE}) and Direction (DIR) inputs control the transceiver functions. Data present at the high impedance output can be stored in either register or both but only one of the two buses can be enabled as outputs at any one time. The Select controls (SAB and SBA) can multiplex stored and transparent (real time) data. The Direction control determines which data bus will receive data when the Output Enable (\overline{OE}) is LOW. In the high impedance mode (Output Enable HIGH), A data can be stored in one register and B data can be stored in the other register. The clocks are not gated with the Direction (DIR) and Output Enable (\overline{OE}) terminals; data at the A or B terminals can be clocked into the storage flip-flops at any time.

Pinout

CD74FCT646
(PDIP, SOIC, SSOP)
TOP VIEW

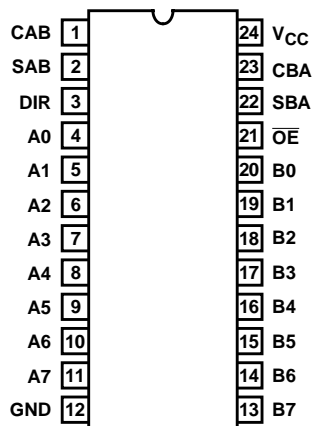

CD74FCT646

Functional Diagram

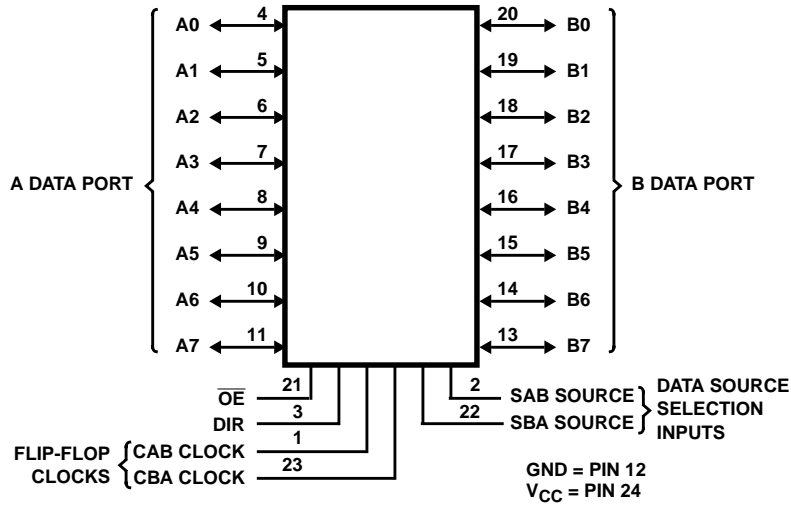

TRUTH TABLE (Note 1)

INPUTS						DATA I/O (Note 2)		OPERATION OR FUNCTION
OE	DIR	CAB	CBA	SAB	SBA	A0 THRU A7	B0 THRU B7	CD74FCT646
X	X	↑	X	X	X	Input	Not Specified	Store A, B Unspecified
X	X	X	↑	X	X	Not Specified	Input	Store B, A Unspecified
H	X	↑	↑	X	X	Input	Input	Store A and B Data
H	X	H or L	H or L	X	X			Isolation, Hold Storage
L	L	X	X	X	L	Output	Input	Real Time B Data to A Bus
L	L	X	H or L	X	H			Stored B Data to A Bus
L	H	X	X	L	X	Input	Output	Real Time A Data to B Bus
L	H	H or L	X	H	X			Stored A Data to B Bus

NOTES:

1. H= HIGH Voltage Level
 L = LOW Voltage Level
 ↑ = Transition from Low to High
 X = Immaterial
2. The data output functions may be enabled or disabled by various signals at the \overline{OE} and DIR inputs. Data input functions are always enabled, i.e., data at the bus pins will be stored on every low to high transition of the clock inputs. To prevent excess currents in the high Z modes, all I/O terminals should be terminated with 10kΩ resistors.

CD74FCT646

IEC Logic Symbol

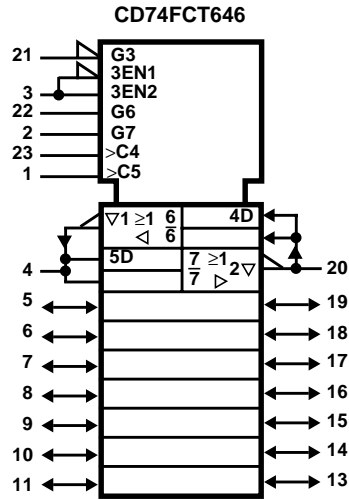

CD74FCT646

Absolute Maximum Ratings

DC Supply Voltage (V_{CC})	-0.5V to 6V
DC Diode Current, I_{IK} (For $V_I < -0.5V$)	-20mA
DC Output Diode Current, I_{OK} (for $V_O < -0.5V$)	-50mA
DC Output Sink Current per Output Pin, I_O	70mA
DC Output Source Current per Output Pin, I_O	-30mA
DC V_{CC} Current (I_{CC})	140mA
DC Ground Current (I_{GND})	528mA

Thermal Information

Thermal Resistance (Typical, Note 3)	θ_{JA} ($^{\circ}C/W$)
PDIP Package	75
SOIC Package	75
SSOP Package	125
Maximum Junction Temperature	150 $^{\circ}C$
Maximum Storage Temperature Range	-65 $^{\circ}C$ to 150 $^{\circ}C$
Maximum Lead Temperature (Soldering 10s)	300 $^{\circ}C$ (SOIC and SSOP-Lead Tips Only)

Operating Conditions

Operating Temperature Range, T_A	0 $^{\circ}C$ to 70 $^{\circ}C$
Supply Voltage Range, V_{CC}	4.75V to 5.25V
DC Input Voltage, V_I	0 to V_{CC}
DC Output Voltage, V_O	0 to $\leq V_{CC}$
Input Rise and Fall Slew Rate, dt/dv	0 to 10ns/V

CAUTION: Stresses above those listed in "Absolute Maximum Ratings" may cause permanent damage to the device. This is a stress only rating and operation of the device at these or any other conditions above those indicated in the operational sections of this specification is not implied.

NOTE:

- θ_{JA} is measured with the component mounted on an evaluation PC board in free air.

Electrical Specifications Commercial Temperature Range 0 $^{\circ}C$ to 70 $^{\circ}C$, V_{CC} Max = 5.25V, V_{CC} Min = 4.75V (Note 6)

PARAMETER	SYMBOL	TEST CONDITIONS		V_{CC} (V)	AMBIENT TEMPERATURE (T_A)				UNITS
		V_I (V)	I_O (mA)		25 $^{\circ}C$		0 $^{\circ}C$ TO 70 $^{\circ}C$		
					MIN	MAX	MIN	MAX	
High Level Input Voltage	V_{IH}			4.75 to 5.25	2	-	2	-	V
Low Level Input Voltage	V_{IL}			4.75 to 5.25	-	0.8	-	0.8	V
High Level Output Voltage	V_{OH}	V_{IH} or V_{IL}	-15	Min	2.4	-	2.4	-	V
Low Level Output Voltage	V_{OL}	V_{IH} or V_{IL}	64	Min	-	0.55	-	0.55	V
High Level Input Current	I_{IH}	V_{CC}		Max	-	0.1	-	1	μA
Low Level Input Current	I_{IL}	GND		Max	-	-0.1	-	-1	μA
Three-State Leakage Current	I_{OZH}	V_{CC}		Max	-	0.5	-	10	μA
	I_{OZL}	GND		Max	-	-0.5	-	-10	μA
Input Clamp Voltage	V_{IK}	V_{CC} or GND	-18	Min	-	-1.2	-	-1.2	V
Short Circuit Output Current (Note 4)	I_{OS}	$V_O = 0$ V_{CC} or GND		Max	-60	-	-60	-	mA
Quiescent Supply Current, MSI	I_{CC}	V_{CC} or GND	0	Max	-	8	-	80	μA
Additional Quiescent Supply Current per Input Pin TTL Inputs High, 1 Unit Load	ΔI_{CC}	3.4V (Note 5)		Max	-	1.6	-	1.6	mA

NOTES:

- Not more than one output should be shorted at one time. Test duration should not exceed 100ms.
- Inputs that are not measured are at V_{CC} or GND.
- FCT Input Loading: All inputs are 1 unit load. Unit load is ΔI_{CC} limit specified in Electrical Specifications table, e.g., 1.6mA Max. at 70 $^{\circ}C$.

CD74FCT646

Switching Specifications Over Operating Range FCT Series $t_r, t_f = 2.5\text{ns}$, $C_L = 50\text{pF}$, R_L (Figure 1) (Note 7)

PARAMETER	SYMBOL	V_{CC} (V)	25°C	0°C TO 70°C		UNITS
			TYP	MIN	MAX	
Propagation Delays		(Note 8)				
Store An → Bn, Store Bn → An, An → Bn, Bn → An	t_{PLH}, t_{PHL}	5	6.8	2	9	ns
Select to Data	t_{PLH}, t_{PHL}	5	8.3	2	11	ns
Output Enable to Output	t_{PZL}, t_{PZH}	5	10.5	2	14	ns
Output Disable to Output	t_{PLZ}, t_{PHZ}	5	6.8	2	9	ns
Power Dissipation Capacitance	C_{PD} (Note 8)	-	-	-	-	pF
Minimum (Valley) V_{OHV} During Switching of Other Outputs (Output Under Test Not Switching)	V_{OHV}	5	0.5	-	-	V
Maximum (Peak) V_{OLP} During Switching of Other Outputs (Output Under Test Not Switching)	V_{OLP}	5	1	-	-	V
Input Capacitance	C_I	-	-	-	10	pF
Input/Output Capacitance	$C_{I/O}$	-	-	-	15	pF

NOTES:

7. 5V: Minimum is at 5.25V for 0°C to 70°C, Maximum is at 4.75V for 0°C to 70°C, Typical is at 5V.

8. C_{PD} , measured per flip-flop, is used to determine the dynamic power consumption.

P_D (per package) = $V_{CC} I_{CC} + \Sigma(V_{CC}^2 f_I C_{PD} + V_O^2 f_O C_L + V_{CC} \Delta I_{CC} D)$ where:

V_{CC} = supply voltage

ΔI_{CC} = flow through current x unit load

C_L = output load capacitance

D = duty cycle of input high

f_O = output frequency

f_I = input frequency

Prerequisite For Switching

PARAMETER	SYMBOL	V_{CC} (V)	25°C	0°C TO 70°C		UNITS
			TYP	MIN	MAX	
Maximum Frequency	f_{MAX}	5 (Note 9)	-	85	-	ns
Data to Clock Setup Time	t_{SU}	5	-	4	-	ns
Data to Clock Hold Time	t_H	5	-	2	-	ns
Clock Pulse Width	t_W	5	-	6	-	ns

NOTE:

9. 5V: Minimum is at 4.75V for 0°C to 70°C, Typical is at 5V.

Test Circuits and Waveforms

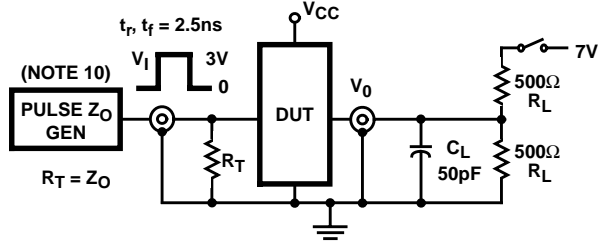

NOTE:
 10. Pulse Generator for All Pulses: Rate \leq 1.0MHz; $Z_{OUT} \leq 50\Omega$;
 $t_f, t_r \leq 2.5ns$.

FIGURE 1. TEST CIRCUIT

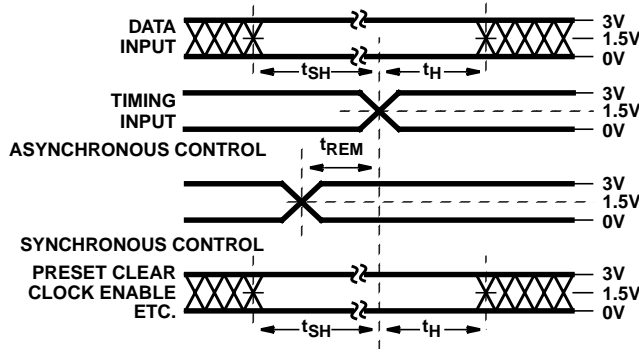

FIGURE 2. SETUP, HOLD, AND RELEASE TIMING

SWITCH POSITION	
TEST	SWITCH
$t_{PLZ}, t_{PZL},$ Open Drain	Closed
$t_{PHZ}, t_{PZH}, t_{PLH}, t_{PHL}$	Open

DEFINITIONS:

C_L = Load capacitance, includes jig and probe capacitance.

R_T = Termination resistance, should be equal to Z_{OUT} of the Pulse Generator.

$V_{IN} = 0V$ to 3V.

Input: $t_r = t_f = 2.5ns$ (10% to 90%), unless otherwise specified

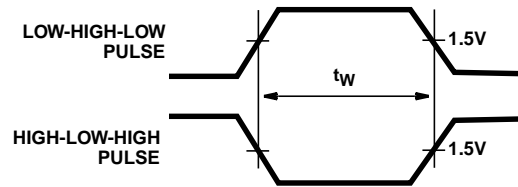

FIGURE 3. PULSE WIDTH

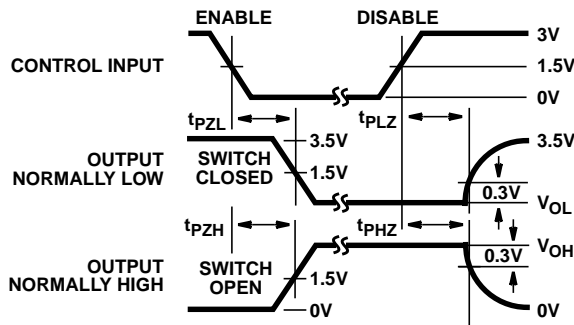

FIGURE 4. ENABLE AND DISABLE TIMING

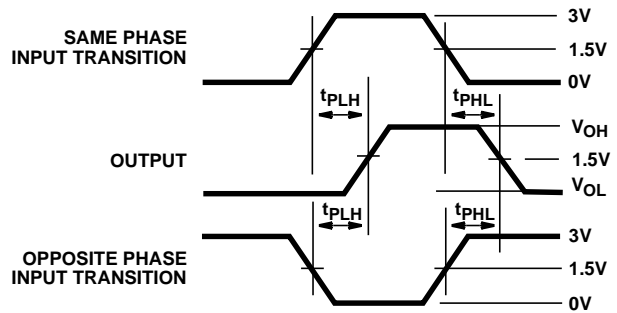
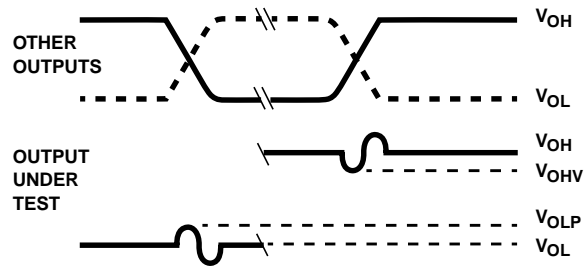

FIGURE 5. PROPAGATION DELAY

Test Circuits and Waveforms (Continued)



NOTES:

11. V_{OLP} is measured with respect to a ground reference near the output under test. V_{OHV} is measured with respect to V_{OH} .
12. Input pulses have the following characteristics:
 $P_{RR} \leq 1\text{MHz}$, $t_r = 2.5\text{ns}$, $t_f = 2.5\text{ns}$, skew 1ns.
13. R.F. fixture with 700MHz design rules required. IC should be soldered into test board and bypassed with $0.1\mu\text{F}$ capacitor. Scope and probes require 700MHz bandwidth.

FIGURE 6. SIMULTANEOUS SWITCHING TRANSIENT WAVEFORMS

IMPORTANT NOTICE

Texas Instruments and its subsidiaries (TI) reserve the right to make changes to their products or to discontinue any product or service without notice, and advise customers to obtain the latest version of relevant information to verify, before placing orders, that information being relied on is current and complete. All products are sold subject to the terms and conditions of sale supplied at the time of order acknowledgement, including those pertaining to warranty, patent infringement, and limitation of liability.

TI warrants performance of its semiconductor products to the specifications applicable at the time of sale in accordance with TI's standard warranty. Testing and other quality control techniques are utilized to the extent TI deems necessary to support this warranty. Specific testing of all parameters of each device is not necessarily performed, except those mandated by government requirements.

CERTAIN APPLICATIONS USING SEMICONDUCTOR PRODUCTS MAY INVOLVE POTENTIAL RISKS OF DEATH, PERSONAL INJURY, OR SEVERE PROPERTY OR ENVIRONMENTAL DAMAGE ("CRITICAL APPLICATIONS"). TI SEMICONDUCTOR PRODUCTS ARE NOT DESIGNED, AUTHORIZED, OR WARRANTED TO BE SUITABLE FOR USE IN LIFE-SUPPORT DEVICES OR SYSTEMS OR OTHER CRITICAL APPLICATIONS. INCLUSION OF TI PRODUCTS IN SUCH APPLICATIONS IS UNDERSTOOD TO BE FULLY AT THE CUSTOMER'S RISK.

In order to minimize risks associated with the customer's applications, adequate design and operating safeguards must be provided by the customer to minimize inherent or procedural hazards.

TI assumes no liability for applications assistance or customer product design. TI does not warrant or represent that any license, either express or implied, is granted under any patent right, copyright, mask work right, or other intellectual property right of TI covering or relating to any combination, machine, or process in which such semiconductor products or services might be or are used. TI's publication of information regarding any third party's products or services does not constitute TI's approval, warranty or endorsement thereof.