

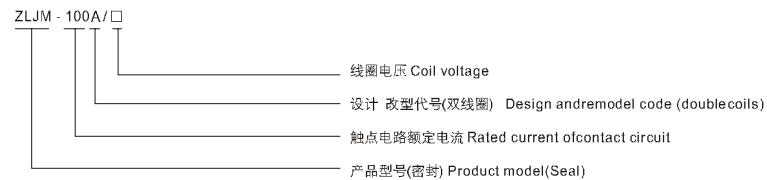

ZLJM-100A

Series contactors
系列接触器

产品型号含义 Nomination(nomogram)



使用条件 Use conditions required

环境温度 Ambient temperature: -25~+40°C
 相对湿度 Relative humidity: +20°C达98%(upto 98% @ +20°C)
 固定处的振动频率 Vibration freq. at the fixed position:
 3g、1~50Hz 振幅 0.5mm
 3g、1~50Hz ampl 0.5mm
 安装方向 Mounting directions: 任意 Optional

外形安装图 Configurational mounting diagram

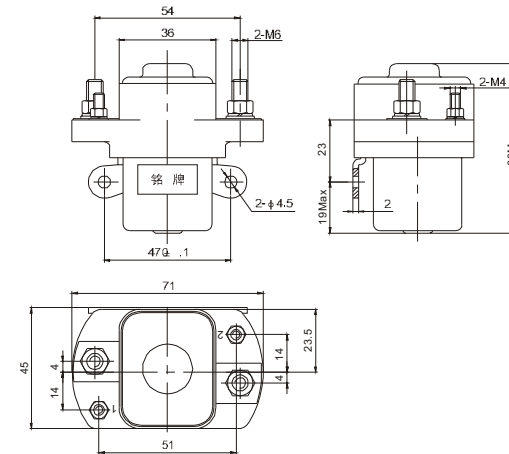

线路原理图 Circuit diagram

L1: 启动绕组 Start winding
 L2: 保持绕组 Hold winding
 3、4: 触点接线端(3、4: contact terminal)
 1、2为线圈接线端(1、2 coil terminal)

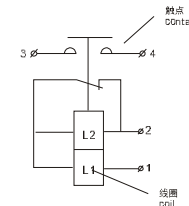

简要技术数据 Basic technical data

编号 NO.	参数名称 Parameters	产品代号 Product code	
		ZLJM-100A系列 series	
1	线圈额定电压 Rated coil volt(VDC)	12、24、30、48、60、72、120等(etc)	
2	线圈功耗 Coil Power dissipation(W)	6.5-8	
3	20°C冷态启动线圈最大电流 Max. coil start current in cold state at 20°C(A)	5	
4	触点电路额定电压 Rated volt of contact circuit(V DC)	48	
5	触点电路额定负载电流 Rated load current of contact circuit(A)	100A	
6	(20±5)°C下、冷态动作电压(V) Operating volt in cold state at (20±5)°C	吸合 Pick-up	不大于线圈额定电压的70% Not above 70% of rated coil volt
		释放 Release	线圈额定电压的(5~30)% (5~30)% of rated coil volt
7	100A负载下主触点接触电压降 Contact volt drop of main contact at 100A	不大于80mV not above 80mV	
8	额定电压下最大动作时间(ms)(线圈不带抑制电器) Max. operating time at rated volt(ms) (Coil with no suppression circuit)	30	
9	抗电强度 Puncture(volt) strength	50Hz 1000V AC 1min	
10	电寿命(τ=0.001s)(次) Electric life(τ=0.001s)(cycles)	50,000 Ops.	
11	机械寿命 Mechanical life	10万次 100,000 Ops.	
12	工作规范 Working duty	连续 Continuous	