

Rectangular Connectors

IAM-F30, G63, F33B, G89, CAM-G62, G62B

FEATURES

1. 1mm + 2mm pitch connector of 30-pole type to be used between a board and a cable.
2. Provided with a lock mechanism that permits a secure connection.
3. A mis-insertion-proof key for fitting is adopted.
4. The service life related to insertion/removal is 5,000 times.
5. 6 pins of the power terminal are mounted. (Rated 2 A terminal)

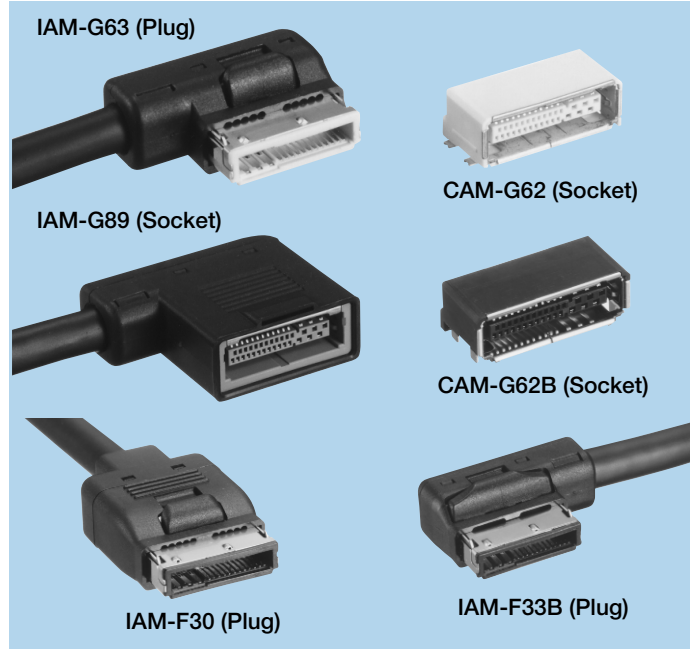

HOW TO ORDER

1. Cable

G63 - 030 -
 1 2 3

- 1 Series No. (F30 : Straight, G63 : Right Angle, F33B : Left Angle, G89 : Right Angle for relay)
- 2 No. of contacts (030 : 30pins)
- 3 Number of specification

2. Receptacle

G62 - 030 -
 1 2 3

- 1 Series No. (G62 : Angle SMD type, G62B : Angle SMD type, For the fitting-side GND only, the PTH type is adopted.)
- 2 No. of contacts (030 : 30pins)
- 3 Number of specification

• Any products mentioned in this catalog are subject to any modification in their appearance and others for improvements without prior notification.
 • The details listed here are not a guarantee of the individual products at the time of ordering. When using the products, you will be asked to check their specifications.

SPECIFICATIONS

ELECTRICAL CHARACTERISTICS

Rated Voltage	30V DC
Rated Current	0.5A(Power terminal : 2A)
Withstanding Voltage	300V AC(rms) 1minute
Insulation Resistance	100MΩ min. (500V DC)
Contact Resistance	100mΩ max.

MECHANICAL CHARACTERISTICS

Life (Matching Cycle)	5,000 times
Total Insertion Force	39.2N max.
Total Withdrawal Force	1.96~39.2N max.
Using Temperature Range	-30~+85°C

MATERIAL & FINISH

Component Parts		Material	Finish
IAM-F30, G63, F33B, G89 Cable Type	Housing	PBT resin	-
	Contact Pin	Copper alloy	Tin reflow plating
	Shield Case	Stainless	Nickel plating
	Cover	PBT resin	-
	Cord Clamper	Steel	-
CAM-G62, G62B Receptacle	Housing	Nylon	(SMD type)
	Contact Pin	Copper alloy	Tin reflow plating
	Shielded Case	Copper alloy	Tin reflow plating

DIMENSIONS

IAM-G63

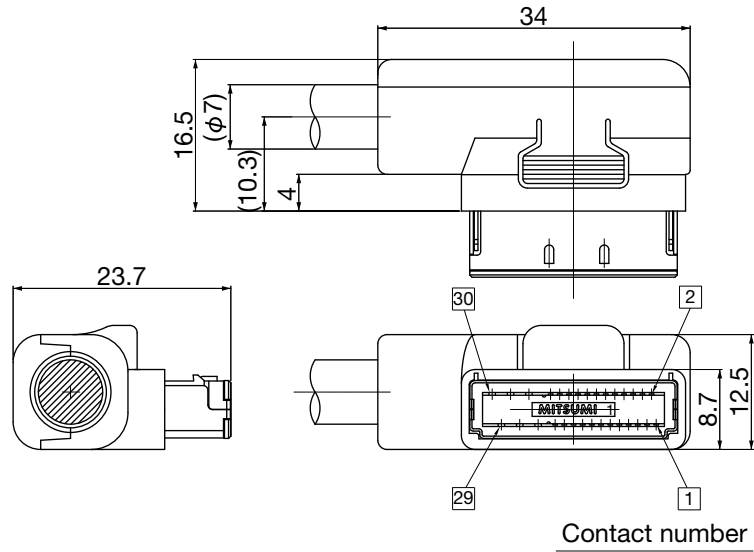

Unit : mm

CAM-G62 (30 pins)

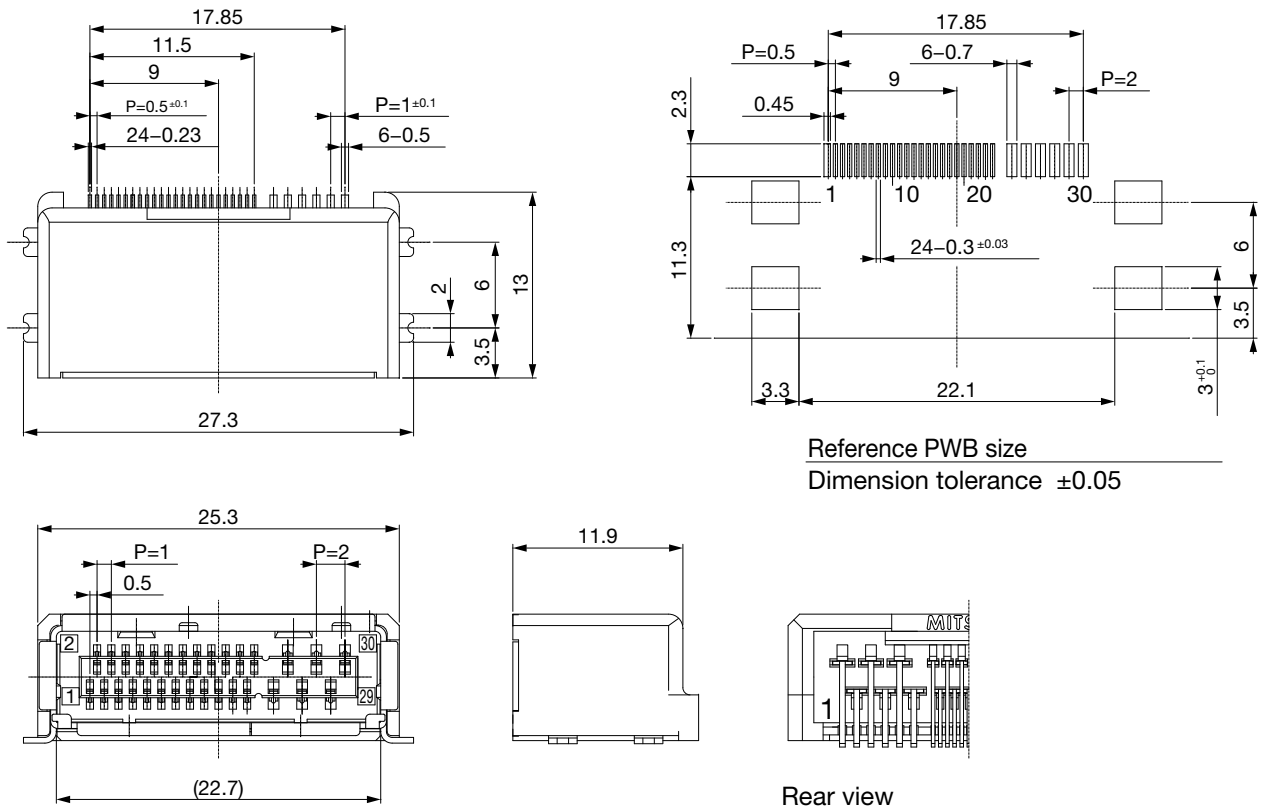

Unit : mm

• Any products mentioned in this catalog are subject to any modification in their appearance and others for improvements without prior notification.
 • The details listed here are not a guarantee of the individual products at the time of ordering. When using the products, you will be asked to check their specifications.

CAM-G62B (30 pins)

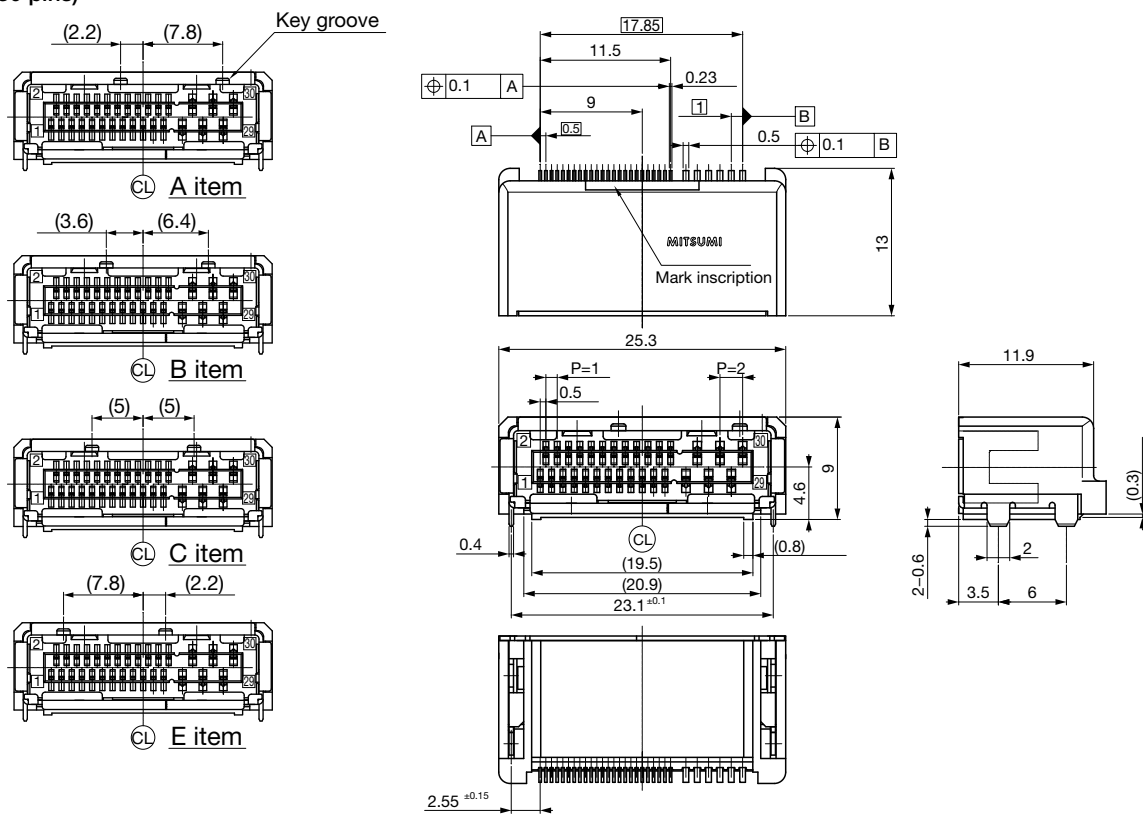

Unit : mm

IAM-G89

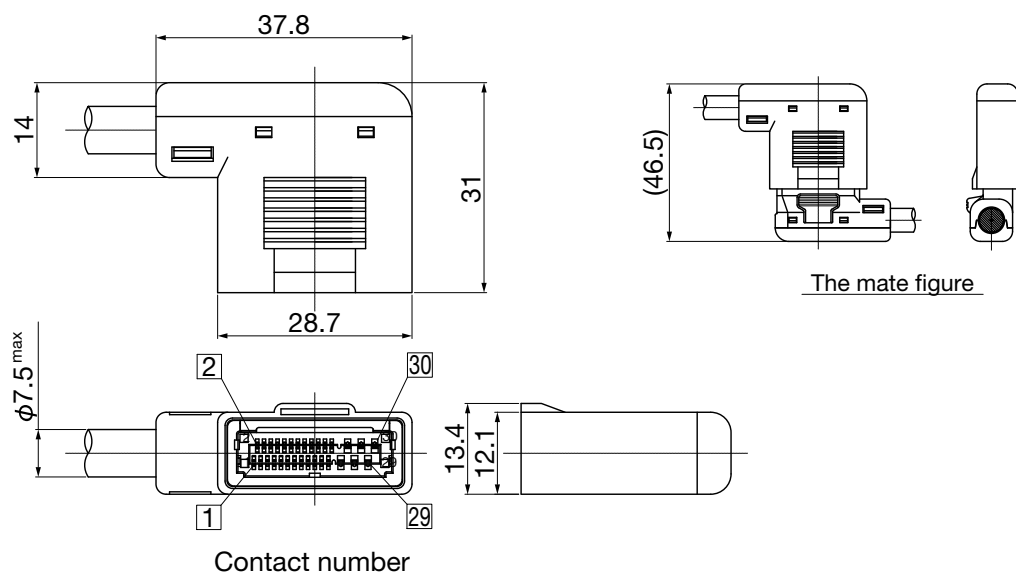

Unit : mm

• Any products mentioned in this catalog are subject to any modification in their appearance and others for improvements without prior notification.
 • The details listed here are not a guarantee of the individual products at the time of ordering. When using the products, you will be asked to check their specifications.

IAM-F30

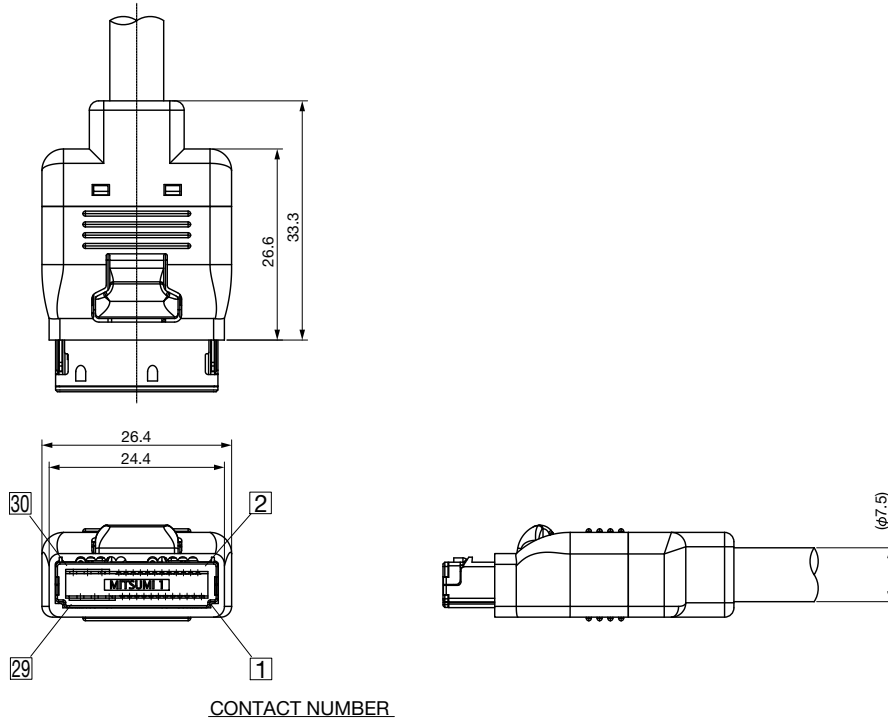

Unit : mm

IAM-F33B

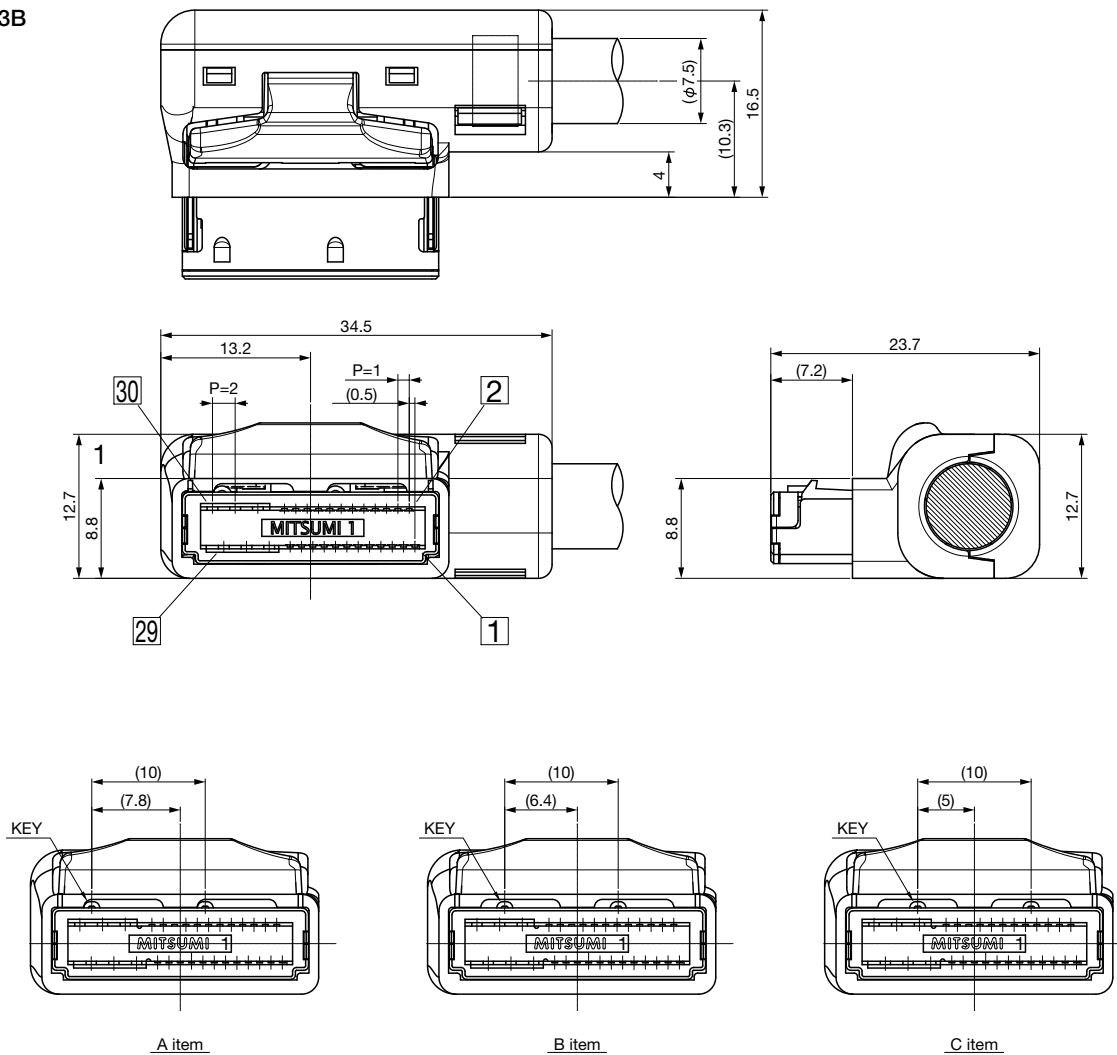

Unit : mm

• Any products mentioned in this catalog are subject to any modification in their appearance and others for improvements without prior notification.
 • The details listed here are not a guarantee of the individual products at the time of ordering. When using the products, you will be asked to check their specifications.