

### Features

- ✧ For surface mounted application
- ✧ Easy pick and place
- ✧ Glass passivated junction chip
- ✧ Low profile package
- ✧ Built-in strain relief
- ✧ Ideal for automated placement
- ✧ Ultrafast recovery time for high efficiency
- ✧ Low forward voltage, low power loss
- ✧ High temperature soldering guaranteed:  
260°C/10 seconds on terminals
- ✧ Meet MSL level 1, per J-STD-020D,  
lead free maximum peak of 260°C
- ✧ Plastic material used carriers Underwriters  
Laboratory Classification 94V-0
- ✧ Epitaxial construction
- ✧ Green compound with suffix "G" on packing  
code & prefix "G" on datecode



### Mechanical Data

- ✧ Case: SMB/DO-214AA
- ✧ Molding Compound meet UL 94V-0 flammability rating
- ✧ Terminals: Pure tin plated, leads free, solderable  
per MIL-STD-750, Method 2026
- ✧ Polarity: Indicated by cathode band
- ✧ Weight: 0.097 grams

### Ordering Information (example)

Part No.	Package	Packing	Packing code	Green Compound Packing code
MUR105S	SMB	850 / 7" REEL	R5	R5G

### Maximum Ratings and Electrical Characteristics

Rating at 25 °C ambient temperature unless otherwise specified.

Single phase, half wave, 60 Hz, resistive or inductive load.

For capacitive load, derate current by 20%

Type Number	Symbol	MUR 105S	MUR 110S	MUR 115S	MUR 120S	MUR 140S	MUR 160S	Units
Maximum Repetitive Peak Reverse Voltage	$V_{RRM}$	50	100	150	200	400	600	V
Maximum RMS Voltage	$V_{RMS}$	35	70	105	140	280	420	V
Maximum DC Blocking Voltage	$V_{DC}$	50	100	150	200	400	600	V
Maximum Average Forward Rectified Current	$I_{F(AV)}$	1						A
Peak Forward Surge Current, 8.3 ms Single Half Sine-wave Superimposed on Rated Load (JEDEC method )	$I_{FSM}$	40				35		A
Maximum Instantaneous Forward Voltage (Note 1) @ 1.0A @ $T_A=25^\circ\text{C}$ @ $T_A=150^\circ\text{C}$	$V_F$	0.875 0.710				1.25 1.05		V
Maximum DC Reverse Current at Rated DC Blocking Voltage @ $T_A=25^\circ\text{C}$ @ $T_A=150^\circ\text{C}$	$I_R$	2 50				5 150		uA uA
Maximum Reverse Recovery Time (Note 2)	$T_{rr}$	25				50		ns
Typical Thermal Resistance (Note 4)	$R_{\theta JL}$	17						$^\circ\text{C/W}$
Operating Temperature Range	$T_J$	-65 to + 175						$^\circ\text{C}$
Storage Temperature Range	$T_{STG}$	-65 to + 175						$^\circ\text{C}$

Note 1: Pulse Test with PW=300usec, 1% Duty Cycle

Note 2: Reverse Recovery Test Condition:  $I_F=0.5A$ ,  $I_R=1.0A$ ,  $I_{RR}=0.25A$

**RATINGS AND CHARACTERISTIC CURVES (MUR105S THRU MUR160S)**

FIG.1 MAXIMUM FORWARD CURRENT DERATING CURVE

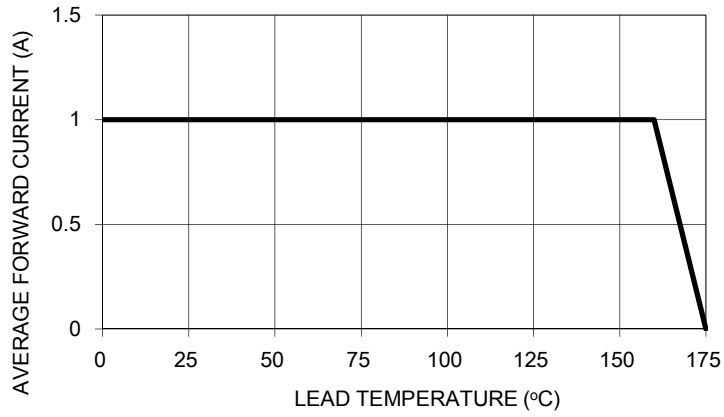

FIG. 2 MAXIMUM NON-REPETITIVE FORWARD SURGE CURRENT

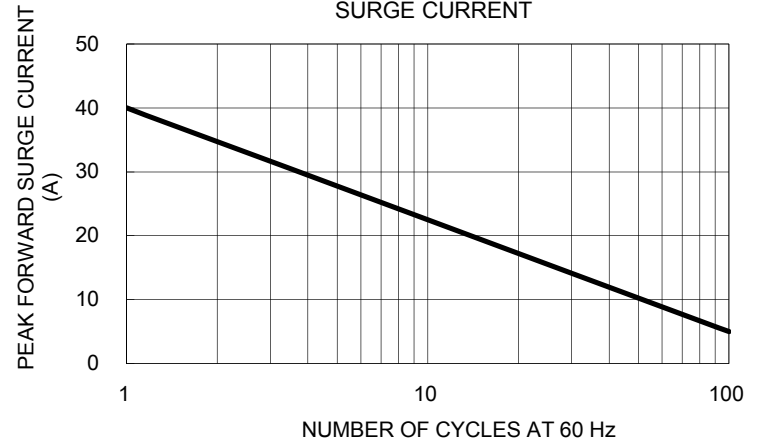

FIG. 3 TYPICAL FORWARD CHARACTERISTICS

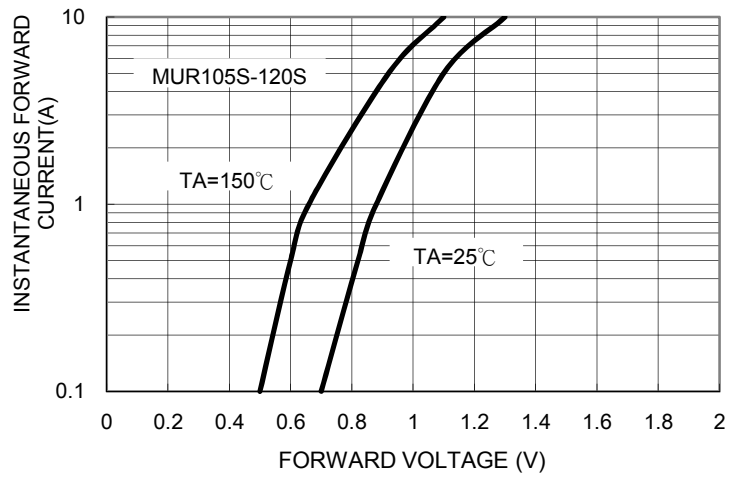

FIG. 4 TYPICAL FORWARD CHARACTERISTICS

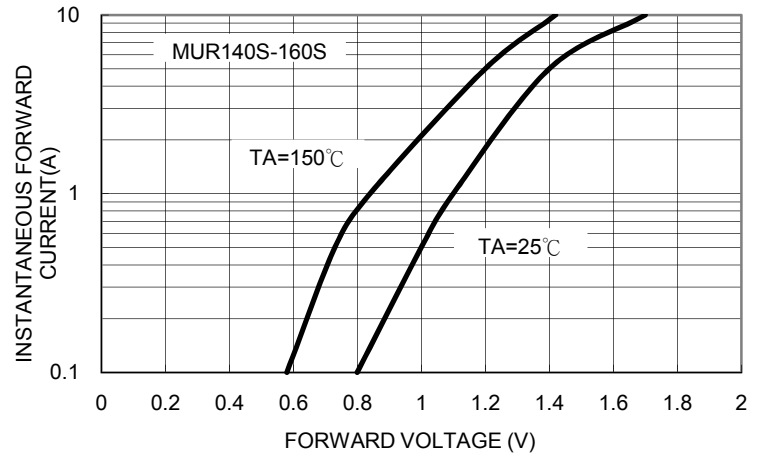

FIG. 5 TYPICAL REVERSE CHARACTERISTICS

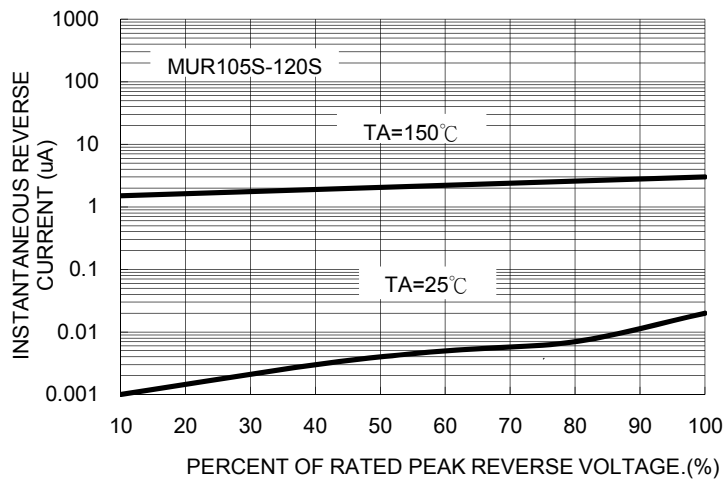

FIG. 6 TYPICAL REVERSE CHARACTERISTICS

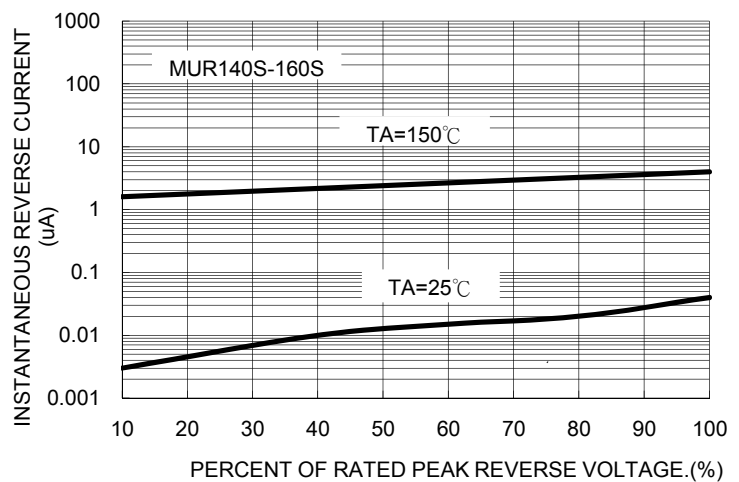
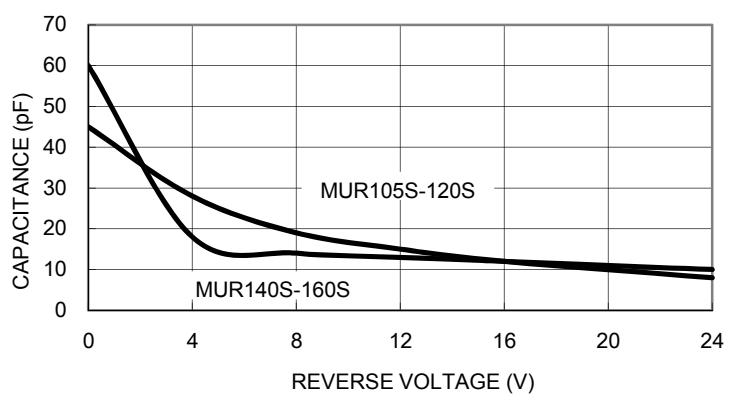

FIG. 7 TYPICAL JUNCTION CAPACITANCE



### Ordering information

Part No.	Package	Packing	Packing code	Green Compound Packing code
MUR1xxS (Note)	SMB	850 / 7" REEL	R5	R5G
	SMB	3K / 13" REEL	R4	R4G
	SMB	3K / 13" REEL	M4	M4G

Note: "x" is Device Code from "05" thru "60".

### Tape & Reel specification

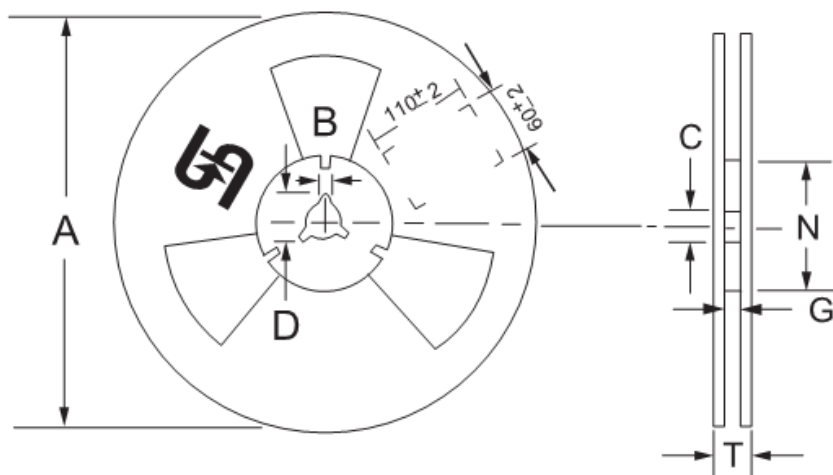
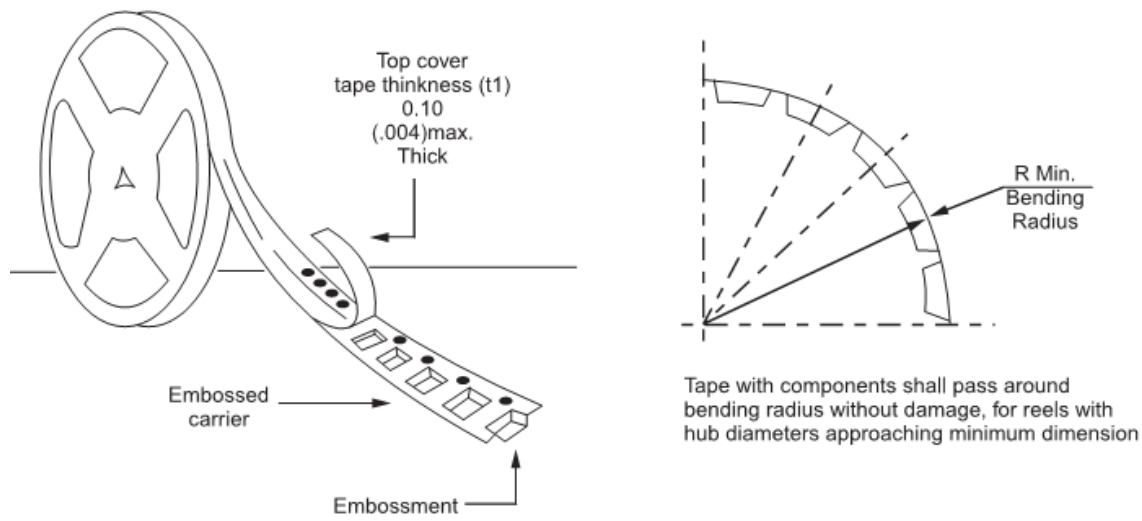

Reel Size	Tape Size	A	B	C	D	N	G	T
		±2.0	±0.4	+0.5;-0.2	min	±1.0	+0.8;-0	max
7"	12mm	178	1.9	13	21	62	12.2	14.6
Reel Size	Tape Size	A	B	C	D	N	G	T
		max	±0.5	±0.5	min	±0.5	+2.0;-0	max
13"	12mm	330	2	13	20.2	75	12.4	18.4

Unit (mm)

### Suggested PAD Layout

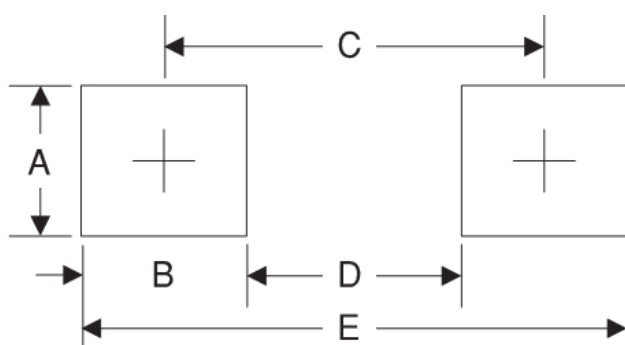

Symbol	Unit(mm)
A	2.3
B	2.5
C	4.3
D	1.8
E	6.7

**Dimensions**

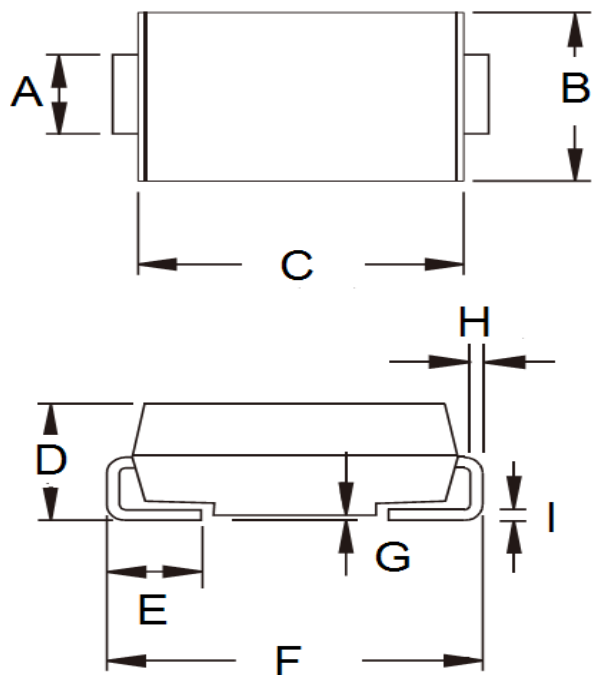

DIM.	Unit(mm)		Unit(inch)	
	Min	Max	Min	Max
A	1.95	2.10	0.077	0.083
B	3.48	3.73	0.137	0.147
C	4.25	4.75	0.167	0.187
D	1.99	2.61	0.078	0.103
E	0.90	1.41	0.035	0.056
F	5.10	5.30	0.201	0.209
G	0.10	0.20	0.004	0.008
H	0.15	0.31	0.006	0.012
I	0.15	0.31	0.006	0.012

**Marking Diagram**

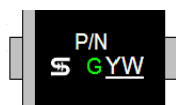

- P/N = Specific Device Code
- G = Green Compound
- YW = Date Code