

# BD1926



## Dual Band 2-Way SMT Power Divider

1700~2300MHz PCS, WCDMA & TD-SCDMA

### Device Features

- Typical Isolation = 24.5 dB
- Typical Insertion Loss = 0.6 dB
- MSL 3 moisture rating
- Small Size and Low Profile
- Lead-free/RoHS-compliant SOT-26 Plastic Package



BD19XX(XX=Wafer number)

### Product Description

BeRex's Divider BD1926 is designed for PCS, WCDMA & TD-SCDMA band with low Insertion Loss and Isolation. This chip is fully passivated for enhanced performance and reliability and packaged in RoHS-compliant with SOT-26 surface mount package.

### Typical Performance<sup>1</sup>

Parameter	Min	Typical	Max	Unit
Frequency Range	1700		2300	MHz
Insertion Loss		0.6	0.8	dB
Isolation	16.5	24.5		dB
IRL(S11)		-16.0	-11.5	dB
ORL(S22/S33)		-24.0	-19.5	dB
Amplitude Balance		0.07	0.2	dB
Phase Balance		1.5	2.0	deg

\*All specifications apply to the following test conditions,

1. Device performance \_ measured on BeRex E/B at 25°C, 50ohm system.
2. Insertion Loss: Above 3.0dB.

### Applications

- Base station Infrastructure
- Commercial/Industrial/Military wireless system

### Absolute Maximum Ratings

Parameter	Rating
Input Power	1W CW dBm
Storage Temperature	-55 to +155°C
Operating Temperature	-40 to +100°C

Operation of this device above any of these parameters may result in permanent damage.

### Evaluation Board Drawing

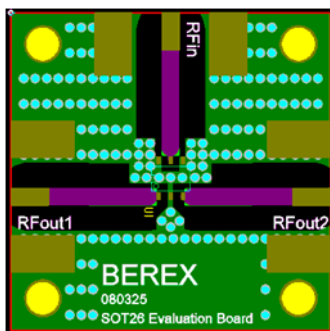

### Function Block Diagram

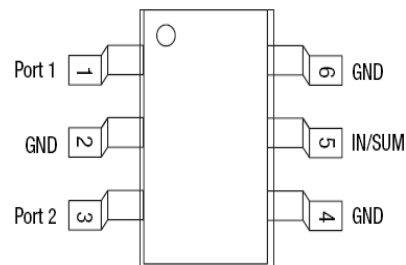

Pins 2,4 and 6 must be DC and RF grounded.

## Dual Band 2-Way SMT Power Divider

1700~2300MHz PCS, WCDMA & TD-SCDMA

### Typical Test Data

Parameters	Unit	PCS, WCDMA & TD-SCDMA				
		1700	1800	1900	2075	2250
Frequency Range	MHz	1700	1800	1900	2075	2250
Insertion Loss	dB	0.51	0.51	0.55	0.63	0.76
Isolation	dB	20.1	22.5	24.8	21.6	16.8
IRL(S11)	dB	-17.4	-17.1	-16.3	-14.1	-11.9
ORL(S22,S33)	dB	-24.9	-25.0	-24.4	-22.7	-19.9
Phase Diff.	deg	1.4	1.5	1.5	1.5	1.4
Amplitude Balance	dB	0.04	0.07	0.07	0.06	0.04

Insertion Loss vs. Frequency

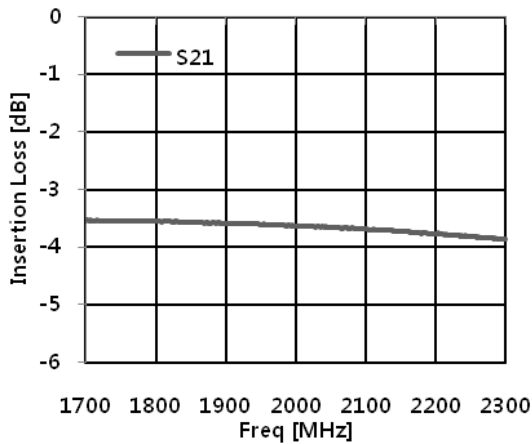

Isolation vs. Frequency

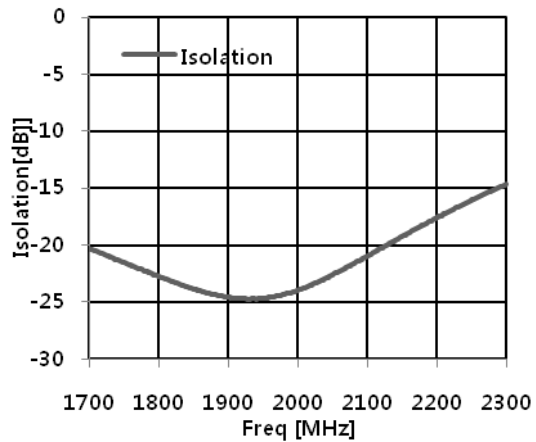

IRL vs. Frequency

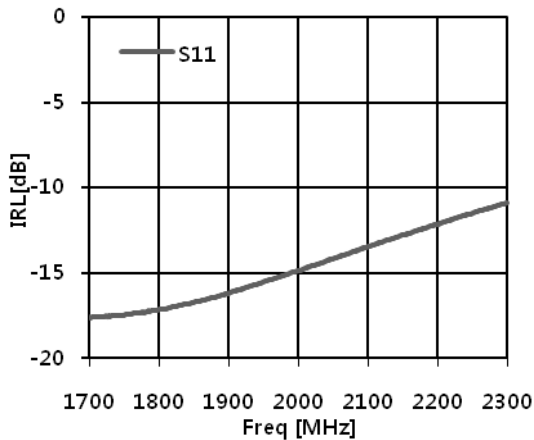

ORL vs. Frequency

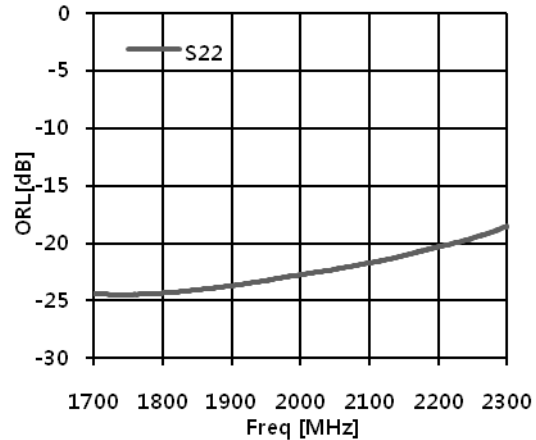

# BD1926



## Dual Band 2-Way SMT Power Divider

1700~2300MHz PCS, WCDMA & TD-SCDMA

### Package Outline Drawing

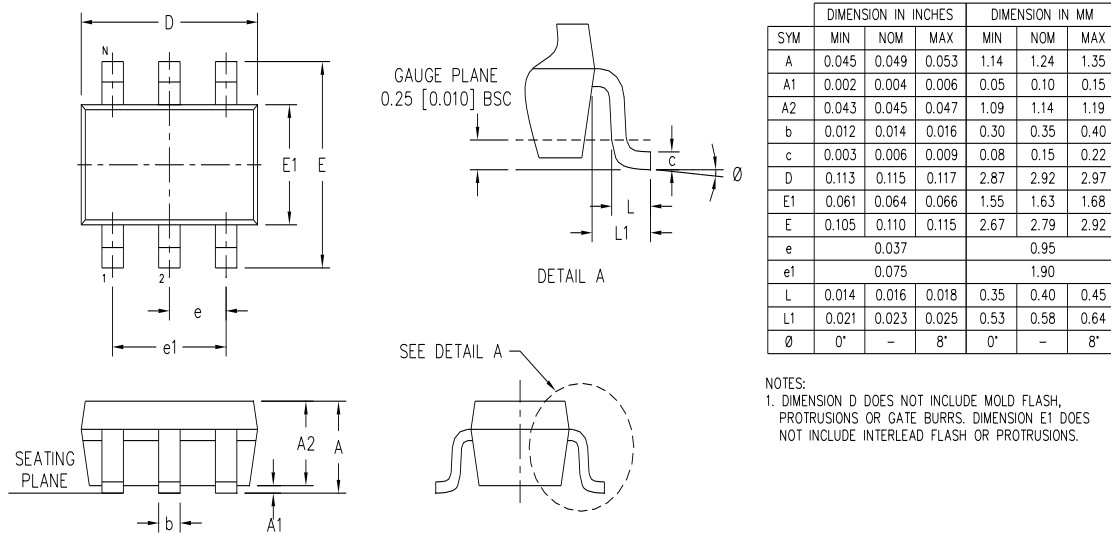

### Suggested PCB Land Pattern and PAD Layout

#### PCB Land Pattern

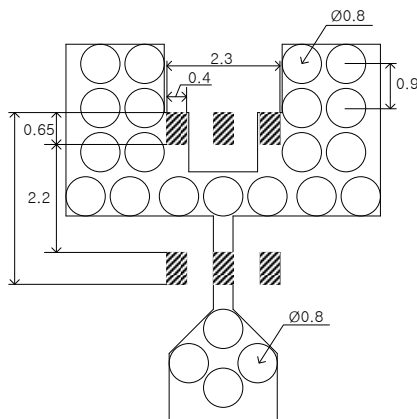

#### PCB Mounting

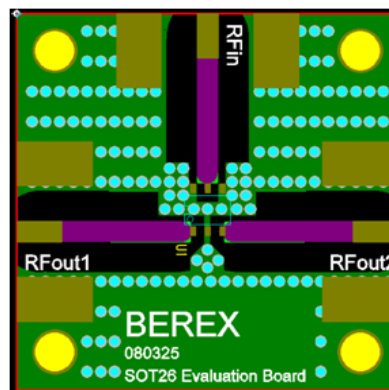

Note : All dimension \_ millimeters

PCB lay out \_ on BeRex website

# BD1926



## Dual Band 2-Way SMT Power Divider

1700~2300MHz PCS, WCDMA & TD-SCDMA

### Package Marking

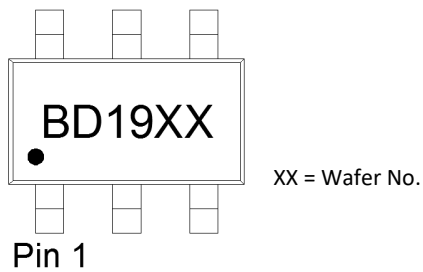

### Tape & Reel

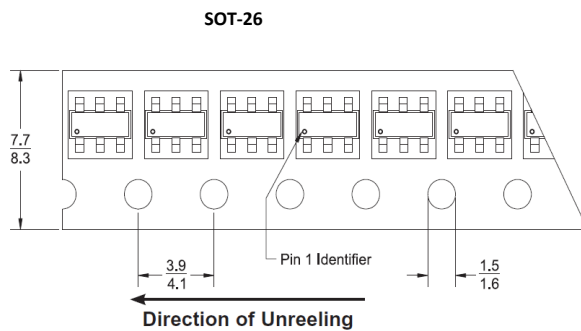

Packaging information:

- Tape Width (mm): 8
- Reel Size (inches): 7
- Device Cavity Pitch (mm): 4
- Devices Per Reel: 3000

### Lead plating finish

#### 100% Tin Matte finish

(All BeRex products undergoes a 1 hour, 150 degree C, Anneal bake to eliminate thin whisker growth concerns.)

# BD1926



## Dual Band 2-Way SMT Power Divider

1700~2300MHz PCS, WCDMA & TD-SCDMA

---

### MSL / ESD Rating

MSL Rating: Level 3 at +265°C convection reflow

Standard: JEDEC Standard J-STD-020



Proper ESD procedures should be followed when handling this device.

### NATO CAGE code:

2	N	9	6	F
---	---	---	---	---