

Features

- EP13 SMD Platform
- RoHS Compliant Product
- Operating temperature: -40 °C~105 °C
- AEC-Q200 Qualified except ESD and Vibration
- Build in TS16949 facility

Electrical Specifications @+25°C

Part Number	Application	Turn ratio			Primary Secondary Isolation	Pri & Sec Core Isolation	Primary Inductance (uH MIN)	Leakage Inductance (uH MAX)	DCR (mΩ MAX)		
		Pri	Sec1	Sec2					Pri	Sec1	Sec2
M1500 M1	Gate Drive Transformer	1	1	1	1500Vac, 2 Seconds	1500Vac, 2 Seconds	210	0.9	180	216	216

Schematic

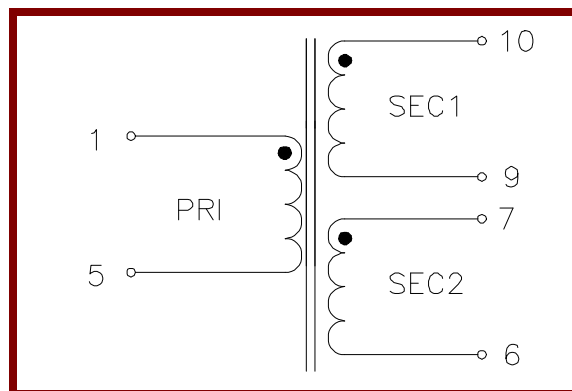

Automotive

Mechanical Outlines

Dimensions $\frac{\text{MM}}{\text{INCH}}$
Unless otherwise specified
All dimensions are $\pm \frac{0.13}{0.005}$

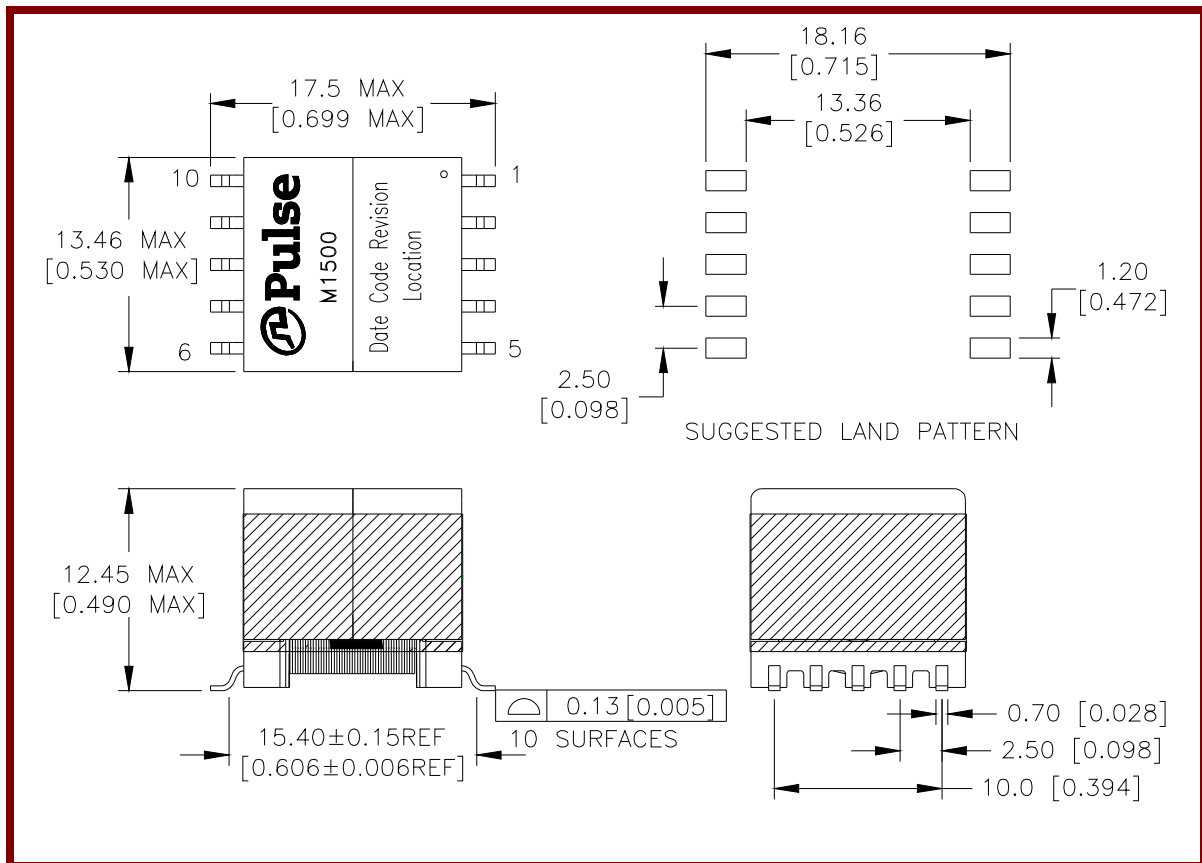

Packing Information

- Type: Tape & Reel
- Quantities per reel: 150PCs
- Reels per box: 5PCs
- Unit Weight: 5.64g