

# RSD1 Remote Display

## Instruction Manual

Original Instructions  
199621 Rev. A  
27 August 2018  
© Banner Engineering Corp. All rights reserved



199621

# Contents

<b>1 Product Description</b>	<b>3</b>
1.1 Models	3
1.2 Overview	3
1.3 Features and Indicators	3
1.3.1 Display	3
1.3.2 RSD1 Buttons	3
<b>2 Installation</b>	<b>5</b>
2.1 Mounting Instructions	5
2.2 Wiring Diagrams	5
2.3 Connection Options	5
2.3.1 Connecting the RSD1 to a Sensor	6
2.3.2 Connecting the RSD1 to a Control System	6
<b>3 Programming a Sensor with the RSD1</b>	<b>7</b>
3.1 RSD1 Menu (MENU)	7
3.2 Sensor Configuration Menu (CONFIG)	7
3.2.1 Import	8
3.2.2 Name	8
3.2.3 Export	8
3.2.4 Delete	8
3.2.5 Detail	9
3.3 Input Menu (RSD1 IN)	9
3.3.1 Input Active	9
3.3.2 Input Type	9
3.3.3 Input Switch	9
3.4 Display Menu (DISPLAY)	10
3.4.1 View	10
3.4.2 Sleep	10
3.5 Lock, Unlock, and OpLock Menu (LOCK)	11
3.5.1 Unlock	11
3.5.2 Lock	11
3.5.3 OpLock	11
3.6 Information Menu (INFO)	11
3.6.1 Diags	12
3.7 Reset Menu (RESET)	12
3.8 End Menu (END)	12
3.9 Factory Default Settings	13
3.10 Remote Input	13
<b>4 Specifications</b>	<b>14</b>
4.1 Dimensions	14
<b>5 Display Menu Full Map</b>	<b>15</b>
<b>6 Accessories</b>	<b>16</b>
6.1 Brackets	16
6.2 Cordsets	16
<b>7 Troubleshooting</b>	<b>18</b>
7.1 Errors	18
<b>8 Contact Us</b>	<b>19</b>
<b>9 Banner Engineering Corp. Limited Warranty</b>	<b>21</b>

# 1 Product Description

## Remote Display and Configuration Tool

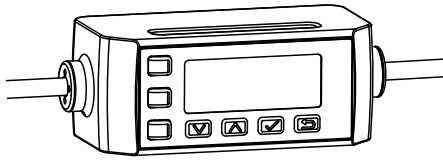

- Allows for configuration of remote sensor heads
- Easy to set up and use with a 2-line, 8-character display
- Ability to display live distance measurement
- Ability to save up to 6 unique configurations
- Not required for continuous operation of configured sensor(s)

## 1.1 Models

Model	Output A and B	Connection
RSD1QP	Configurable	Integral 150 mm (6 in) PVC cable with 5-pin M12/Euro-style quick disconnect

## 1.2 Overview

The RSD1 remote display is designed to provide easy sensor configuration and monitoring with the ability to copy settings between sensors.

## 1.3 Features and Indicators

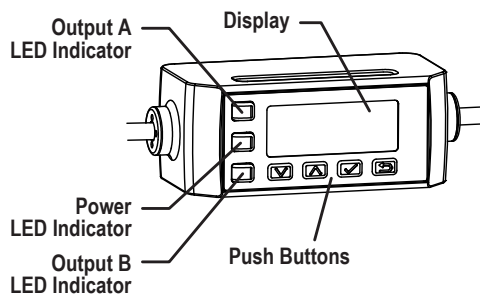

Figure 1. RSD1 Display Features

Three LED indicators on the RSD1 provide ongoing indication of the connected sensor status.

### Output A LED Indicator

- Solid Amber = Output A On
- Off = Output A Off

### Power LED Indicator

- Solid Green = Normal Operation, Power On

### Output B LED Indicator

- Solid Amber = Output B On
- Off = Output B Off

### 1.3.1 Display

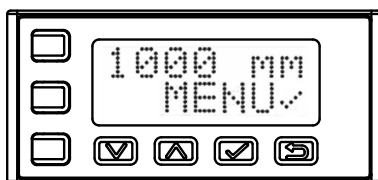

Figure 2. RSD1 Display in Run Mode

The RSD1 display is a 2-line, 8-character LCD. The main screen is the Run mode screen, which shows the real-time measurements of the connected sensor.

### 1.3.2 RSD1 Buttons

Use the RSD1 buttons **Down**, **Up**, **Enter**, and **Escape** to view or change RSD1 settings and information and to program a connected sensor.



### Down and Up Buttons



Press **Down** and **Up** to:

- Navigate the menu systems
- Change programming settings

When navigating the menu systems, the menu items loop.

Press **Down** and **Up** to change setting values. Press and hold the buttons to cycle through numeric values. After changing a setting value, the value slowly flashes until the change is saved using the **Enter** button.



### Enter Button

Press **Enter** to:

- Confirm selection
- Save changes

In the RSD1 Menu, a check mark  in the lower right corner of the display indicates that pressing **Enter** accesses a submenu.

Press **Enter** to save changes. New values flash rapidly, and the sensor returns to the parent menu.



### Escape Button

Press and hold **Escape** for 4 seconds to:

- Access the RSD1 Menu while in Run mode

Press **Escape** to:

- Leave the current menu and return to the parent menu



**Important:** Pressing **Escape** discards any unsaved programming changes.

In the RSD1 Menu, a return arrow  in the upper left corner of the display indicates that pressing **Escape** returns to the parent menu.

Press and hold **Escape** for 2 seconds to return to Run mode from the RSD1 Menu.

## 2 Installation

### 2.1 Mounting Instructions

#### Mount on a DIN Rail

1. Hook the DIN rail clip on the bottom of the RSD1 over the edge of the DIN rail (1).
2. Push the RSD1 up on the DIN rail (1).
3. Pivot the RSD1 onto the DIN rail, pressing until it snaps into place (2).

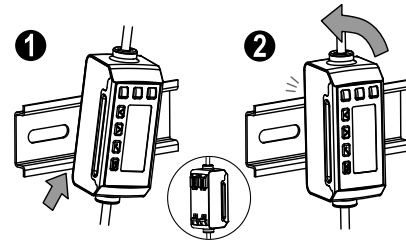

#### Remove from a DIN Rail

1. Push the RSD1 up on the DIN rail (1).
2. Pivot the RSD1 away from the DIN rail and remove it (2).

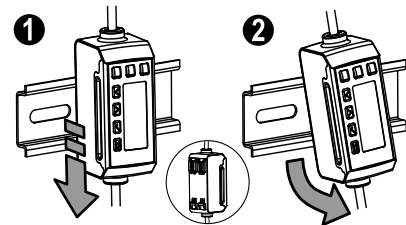

### 2.2 Wiring Diagrams

The following wiring diagrams are examples of different RSD1 outputs. Wiring is dependent on the sensor connected to the RSD1.

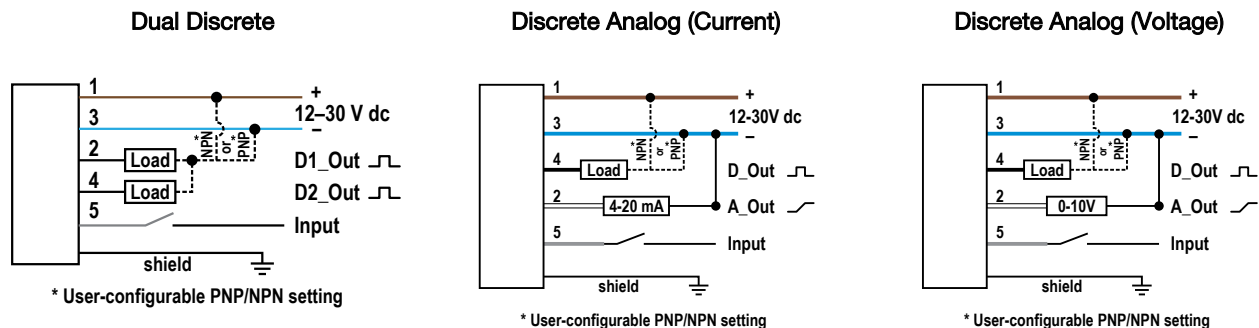

**Note:** When connecting a 5-pin sensors to the RSD1, a double-ended 5-pin to 5-pin cordset is optional. When connecting a 4-pin sensor to the RSD1, a double-ended 4-pin to 5-pin adapter cordset is required.

### 2.3 Connection Options

When connecting the RSD1 to a sensor or control system, an adapter may be required depending on the sensor. For additional information on how to connect the RSD1, see the information below.



**Note:** RSD1 pin-5 (gray wire) is used to communicate with an attached sensor.

### 2.3.1 Connecting the RSD1 to a Sensor

Sensor Connector	Connection Options
<b>5-Pin (5-Wire)</b>	<p>When connecting the RSD1 to a sensor with a 5-pin connector, a double-ended 5-pin cordset can be used to extend the distance between the RSD1 and the sensor.</p> <ul style="list-style-type: none"> <li>• See MQDEC3-5xxSS</li> </ul>
<b>4-Pin (4-Wire)</b>	<p>When connecting the RSD1 to a sensor with a 4-pin connector, an adapter is required to connect RSD1 pin-5 to pin-2 of the sensor.</p> <ul style="list-style-type: none"> <li>• See MQDC-45xxSS</li> </ul> <p>When connecting the RSD1 to a sensor with a 4-pin connector, a double-ended cordset can be used in addition to the adapter to extend the distance between the RSD1 and the sensor.</p> <ul style="list-style-type: none"> <li>• See MQDEC3-5xxSS</li> </ul>

### 2.3.2 Connecting the RSD1 to a Control System

When connecting the RSD1 to a control system, there are many combinations of double-ended and flying leads that can be used to fit your application needs. See sensor specific literature for additional cordset options.



**Note:** A 5-pin to 4-pin converter cable (MQDEC-54xxSS) may be required when connecting to an I/O block if pin-2 on the sensor is configured for remote input.

## 3 Programming a Sensor with the RSD1

When connected to a sensor and in Run Mode, the RSD1 mirrors the connected sensor's display. Program a sensor using the buttons on the RSD1.

For sensor programming information, reference the literature specific to the connected sensor.

In addition to programming a connected sensor, the RSD1 buttons can be disabled to prevent unauthorized or accidental programming changes.

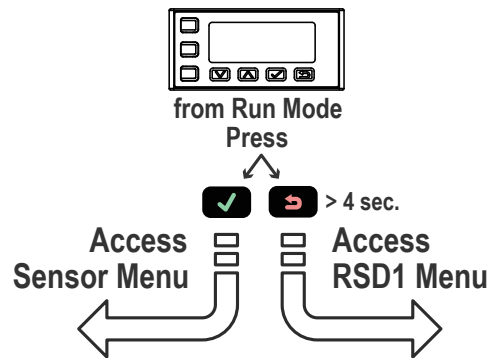

Figure 3. Access Menus Using the RSD1

### 3.1 RSD1 Menu (MENU)

The RSD1 Menu includes several submenus that provide access to view and change RSD1 settings and to view RSD1 information.

To access the RSD1 Menu, press and hold the **Escape**  button > 4 seconds while in Run Mode.

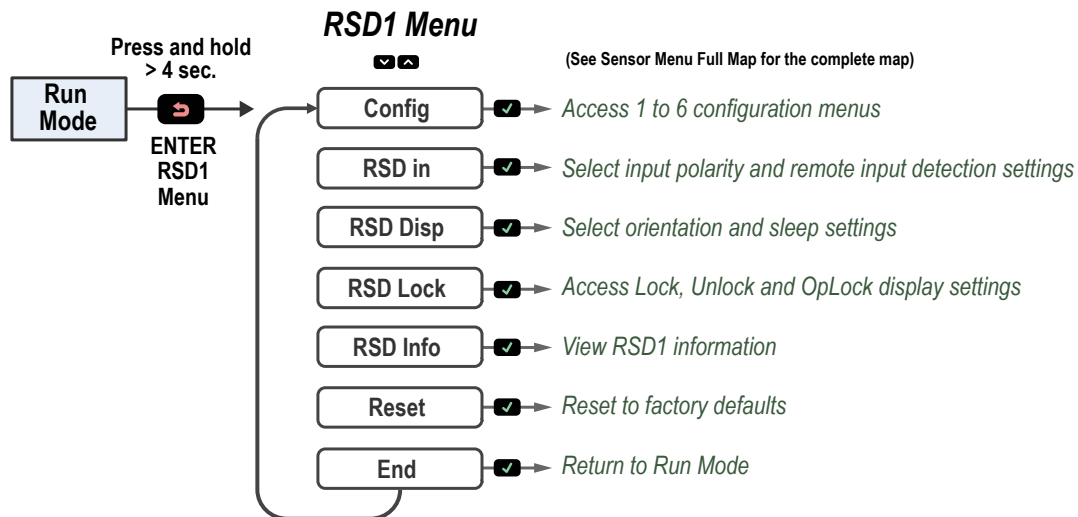

Figure 4. RSD1 Menu Map

See [Display Menu Full Map](#) on page 15 and the Menu sections of this manual for more information.

### 3.2 Sensor Configuration Menu (CONFIG)

There are six sensor configuration slots available to import user configuration data from remote sensors. Once user configuration data is imported, the ability to export the configurations is available.

## RSD1 Config Menu

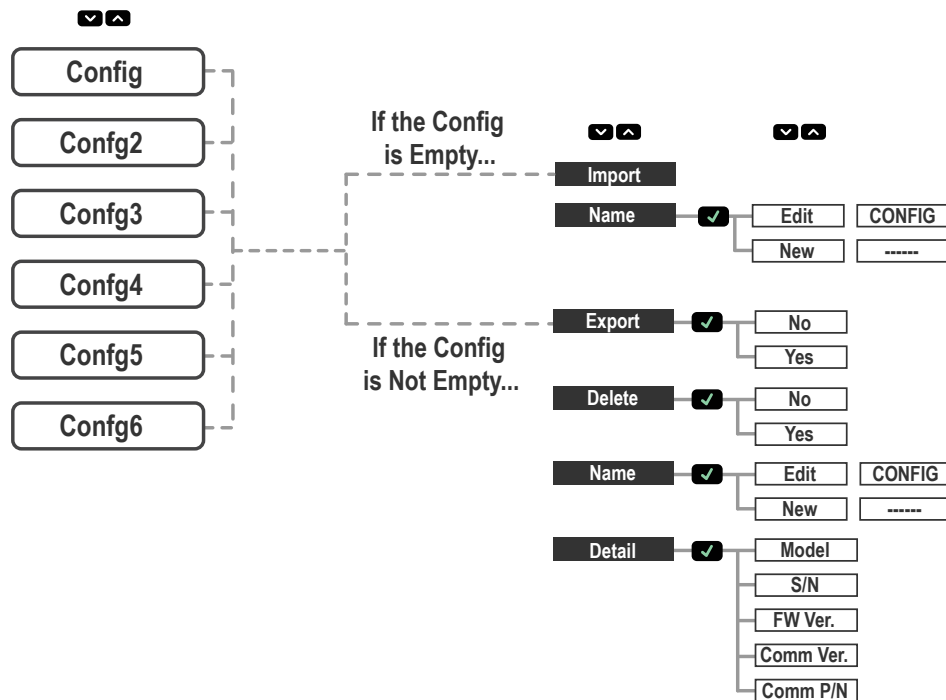

Figure 5. RSD1 Configuration Menu

### 3.2.1 Import

If the user configuration slot is empty, it is available to import from the remote sensor.

After a successful configuration import, the name of the configuration slot will include an asterisk (\*) to show that the configuration slot contains configuration data.

### 3.2.2 Name

The name of the selected configuration slot can be modified.

Function	Description
Edit	The existing configuration name can be edited
New	A new name can be entered



**Note:** An asterisk (\*) precedes the configuration slot name of a configuration that contains configuration data.

### 3.2.3 Export

If a sensor configuration has been imported, the user configuration data can be exported to a connected remote sensor.

To export user configuration data, navigate to the Export menu using the RSD1 push buttons and press the **Enter** button. Navigate to **Yes** and press the **Enter** button. To confirm configuration export, press the **Enter** button a second time.

### 3.2.4 Delete

A configuration slot can be cleared by deleting the user configuration data.

Once user configuration data has been deleted from a configuration slot the asterisk (\*) at the beginning of the configuration slot name will be deleted as well to show that the configuration slot no longer contains user configuration data.



### 3.2.5 Detail

The specific details of the remote sensor that was used to import configuration data will be available to review.

## 3.3 Input Menu (RSD1 IN)

Use the Input menu to view or change the:

- Input polarity
- Remote input detection settings

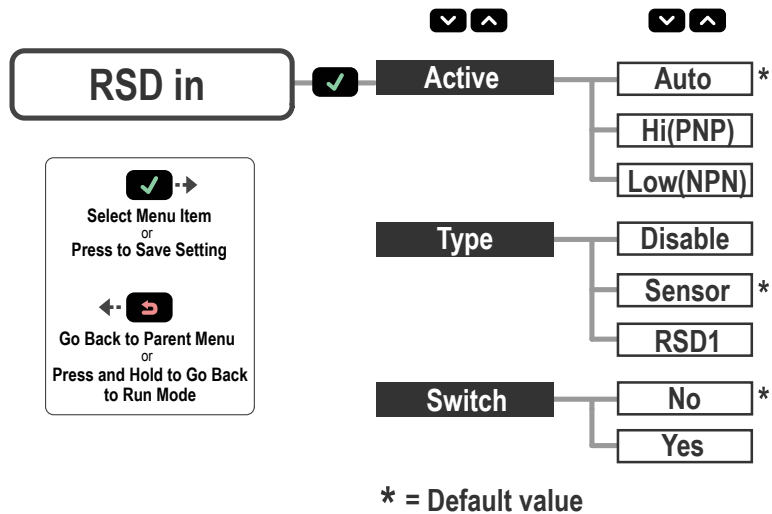

Figure 6. RSD1 Input Menu Map

### 3.3.1 Input Active

The Active option sets the remote input polarity.

**Navigate:** MENU > INPUT > Active

**Default:** Auto

Active Option	Description
Auto	Automatically set the remote input polarity to the setting of the remote sensor
High	Set the remote input polarity to high/PNP
Low	Set the remote input polarity to low/NPN

### 3.3.2 Input Type

The Type option sets the input type.

**Navigate:** Menu > Input > Type

**Default:** Sensor

Input Type	Description
Disable	All remote inputs are ignored
Sensor	Remote input settings are passed directly to the remote sensor. For sensor remote input programming information, reference the literature specific to the connected sensor.
RSD1	Remote input is used to control the export function on the RSD1 and to load new configurations to the attached sensor. For more information, see <a href="#">Remote Input</a> on page 13.

### 3.3.3 Input Switch

The Switch option sets external remote input pulse acceptance.

**Navigate:** MENU > INPUT > Switch

Default: No

Switch Option	Description
Yes	Allows external remote input pulses to select remote input type. For more information, see <a href="#">Remote Input</a> on page 13.
No	Does not allow external remote input pulses to modify remote input selection type.

### 3.4 Display Menu (DISPLAY)

Use the Display menu to view or change the:

- RSD1 display orientation
- RSD1 sleep mode settings

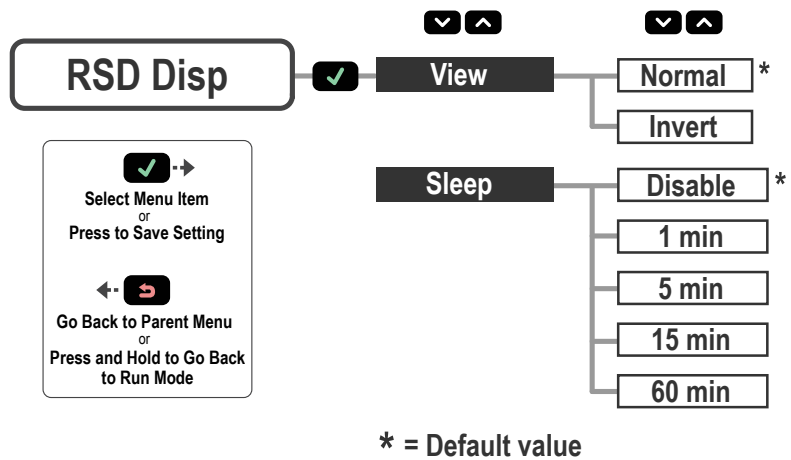

Figure 7. Display Menu Map

#### 3.4.1 View

The View option sets the display orientation of the RSD1. For applications where the display must be mounted so that it is not right-reading, invert the display for readability. The Down and Up buttons do not change when the display is inverted.

Navigate: MENU > DISPLAY > View

Default: Normal

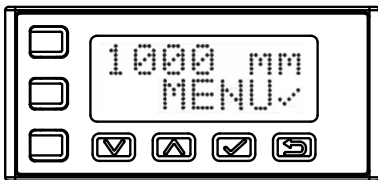

Figure 8. RSD1 Normal Display Orientation

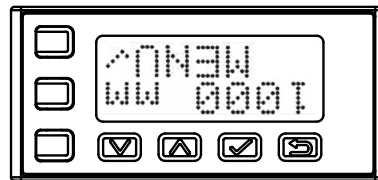

Figure 9. RSD1 Inverted Display Orientation

#### 3.4.2 Sleep

The Sleep option sets when the display is put to sleep. Four timing options are available: 1, 5, 15, or 60 minutes. Sleep mode is disabled by default. Sleep occurs in Run mode and any menu. To wake the sensor and return to the last viewed mode or menu, press any button.

RSD1 sleep settings are independent of the sleep settings of a connected sensor.

Navigate: MENU > DISPLAY > Sleep

Default: Disabled

Sleep Option	Description
Disable	The display will not go to sleep
1min	Turn off the display after 1 minute
5min	Turn off the display after 5 minutes
15min	Turn off the display after 15 minutes
60min	Turn off the display after 60 minutes

### 3.5 Lock, Unlock, and OpLock Menu (LOCK)

The RSD1 can be locked to prevent unauthorized or accidental programming changes.

A lock symbol  displays in the upper left corner of the RSD1 display to indicate when the RSD1 is set to Lock or OpLock. When locked, the menus are available to view settings, but the values cannot be changed. To lock the RSD1 while still allowing for the export of user configuration data, use the OpLock feature.

Unlock the RSD1 to allow programming changes.



**Note:** The Lock and OpLock functions only prevent changes to the RSD1. Changes can still be made to an attached sensor. For sensor lock options, reference the literature specific to the connected sensor.

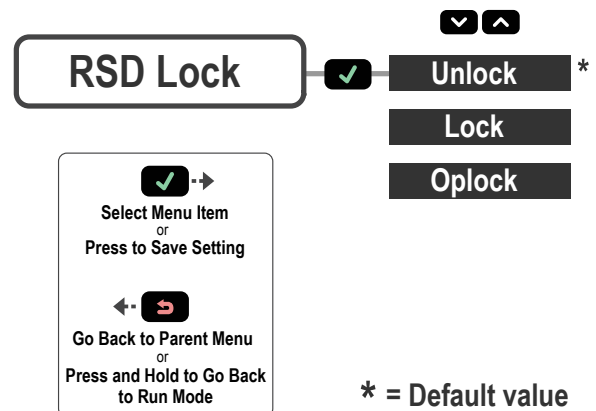

Figure 10. RSD1 Lock Menu Map

**Navigate:** MENU > LOCK

**Default:** Unlocked

#### 3.5.1 Unlock

The RSD1 display can be unlocked to allow programming changes.

#### 3.5.2 Lock

The RSD1 display can be locked to prevent unauthorized or accidental programming changes.

#### 3.5.3 OpLock

The RSD1 display can be locked while still allowing for the export of user configuration data using the OpLock feature.

### 3.6 Information Menu (INFO)

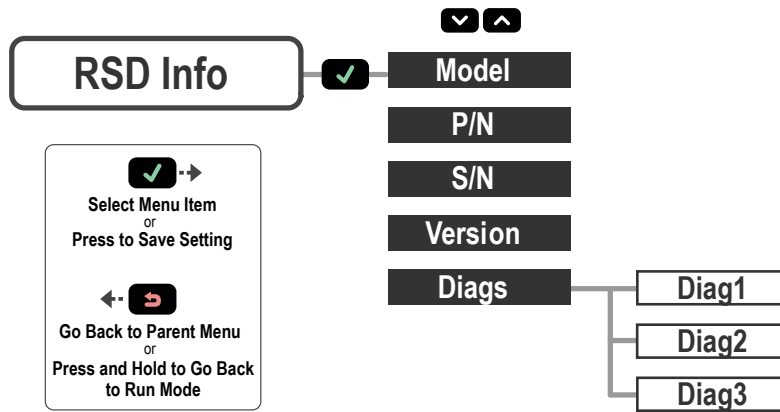

Use the Information menu to view the model, part number (P/N), serial number (S/N), and firmware version (Version) information. Select one of these options to view specific information for the connected sensor. This information is read-only.

**Navigate: MENU > INFO**

### 3.6.1 Diags

Diagnostic display options are available for system diagnostics and may be requested by a Banner Engineering Applications Engineer.

## 3.7 Reset Menu (RESET)

Use the Reset menu to restore the RSD1 to the factory default settings.

**Navigate: MENU > RESET.**

Select **Yes** to apply the factory defaults; select **No** to return to the Reset menu without changing any RSD1 settings.

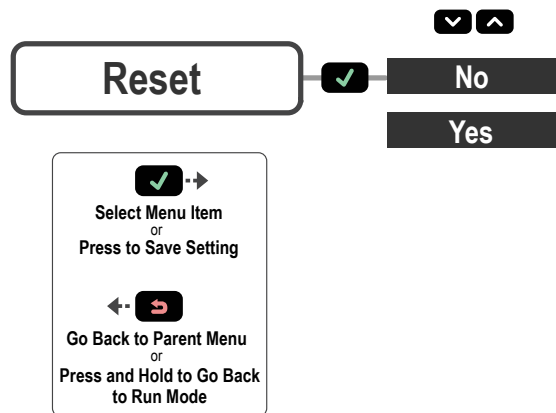

Figure 11. RSD1 Reset Menu Map

## 3.8 End Menu (END)

Select the END menu option to return the RSD1 to Run Mode.

### 3.9 Factory Default Settings

Input Settings	RSD1	Display Settings	RSD1
Active	Auto	View	Normal
Type	Sensor	Sleep	Disabled
Switch	No		

Lock Settings	RSD1
Locked, Unlocked or OpLock	Unlocked

### 3.10 Remote Input

Use the remote input to program the RSD1 remotely. Activate remote input using the RSD1 buttons to navigate to the RSD1 Input Type menu option.

For Active Low, connect the gray input wire to ground (0 V dc), with a remote switch connected between the wire and ground. To use the Active High function, configure the sensor for Active High using the buttons on the sensor, then connect the gray input wire to V+ (12 V dc to 30 V dc). Pulse the remote input according to the diagram and the instructions provided in this manual.

The length of the individual programming pulses is equal to the value T:  $0.04 \text{ seconds} \leq T \leq 0.8 \text{ seconds}$ .

Exit remote programming modes by holding the remote input low for  $> 2 \text{ seconds}$ , or waiting for the automatic 60-second timeout, or by pressing and holding **Escape**  for 2 seconds. The sensor returns to Run mode without saving any new settings.

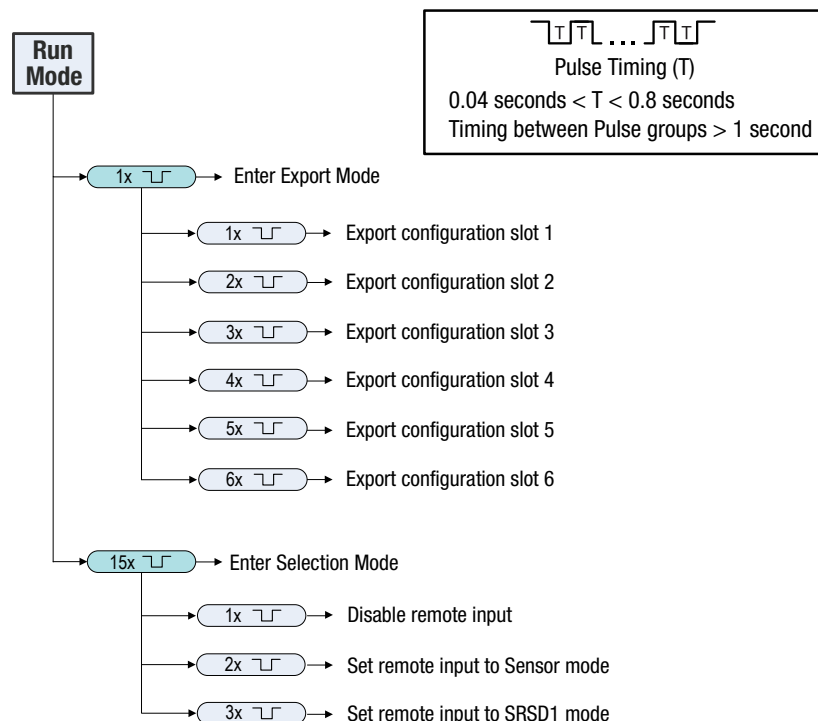

# 4 Specifications

## Supply Voltage

Use only with suitable Class 2 power supply

12 V dc to 30 V dc:

- Max. load of 330 Ω for analog current (4 mA to 20 mA)

15 V dc to 30 V dc:

- Max. load of 500 Ω for analog current (4 mA to 20 mA)

## Power and Current Consumption

Maximum Power Consumption: < 3.6 W (At 30 V dc, 119 mA) with 2 discrete outputs at 50 mA load each

Power Consumption, Normal Run Mode with No Load: < 0.6 W (At 30 V dc, 19 mA)

## Supply Protection Circuitry

Protected against reverse polarity and transient overvoltages

## Output Configuration

**Analog output:** 4 to 20 mA or 0 to 10 V, depending on sensor

**Discrete output rating:** Discrete NPN/PNP, depending on sensor



**Note:** 2 ms output delay with white wire

## Output Ratings

**Discrete Output:** 50 mA maximum (protected against continuous overload and short circuit)

**OFF-state leakage current–PNP:** < 10 μA at 30 V

**OFF-state leakage current–NPN:** < 200 μA at 30 V

**Output saturation voltage–PNP outputs:** < 3 V at 50 mA

**Output saturation voltage–NPN outputs:** < 2 V at 50 mA

**Analog current output:** 330 kΩ max. at 24 V; max. load resistance =  $[(V_{cc}-4.5)/0.02 \Omega]$

**Analog voltage output:** 2.5 kΩ min. load resistance

## Connection

Integral 150 mm (6 in) PVC cable with 5-pin M12/Euro-style quick disconnect

## Construction

Housing: Polycarbonate

## Environmental Rating

IEC IP65

## Operating Temperature

-10 °C to +50 °C (+14 °F to +122 °F)

## Storage Temperature

-40 °C to +70 °C (-40 °F to +158 °F)

## Vibration and Mechanical Shock

All models meet MIL-STD-202G, Method 201A requirements. Also meets IEC 60947-5-2. Vibration: 10 Hz to 60 Hz maximum, 0.06 inch (1.52 mm) double amplitude, 10G maximum acceleration per IEC 60947-5-2. MIL-STD-202G, Method 213B, Condition I (100G 6x along X, Y and Z axes, 18 shocks), with sensor operating. Also meets IEC 947-5-2 requirements: 30G 11 ms duration, half sine wave.

## Certifications



## 4.1 Dimensions

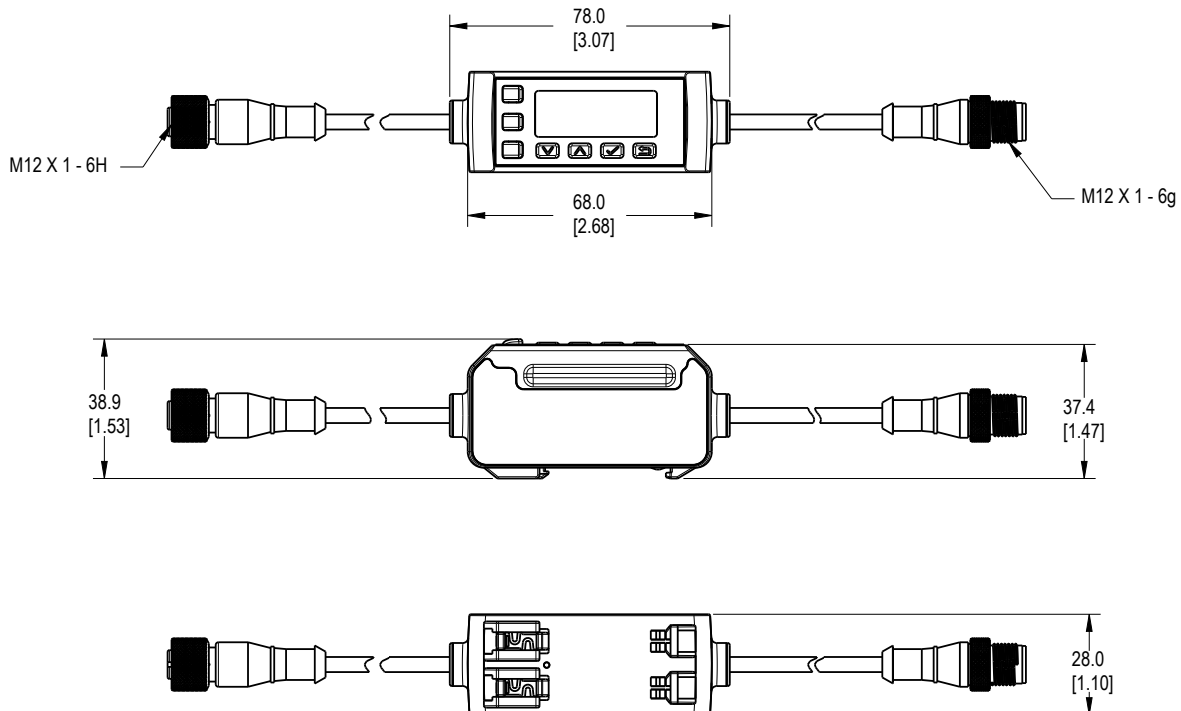

All measurements are listed in millimeters [inches], unless noted otherwise.

# 5 Display Menu Full Map

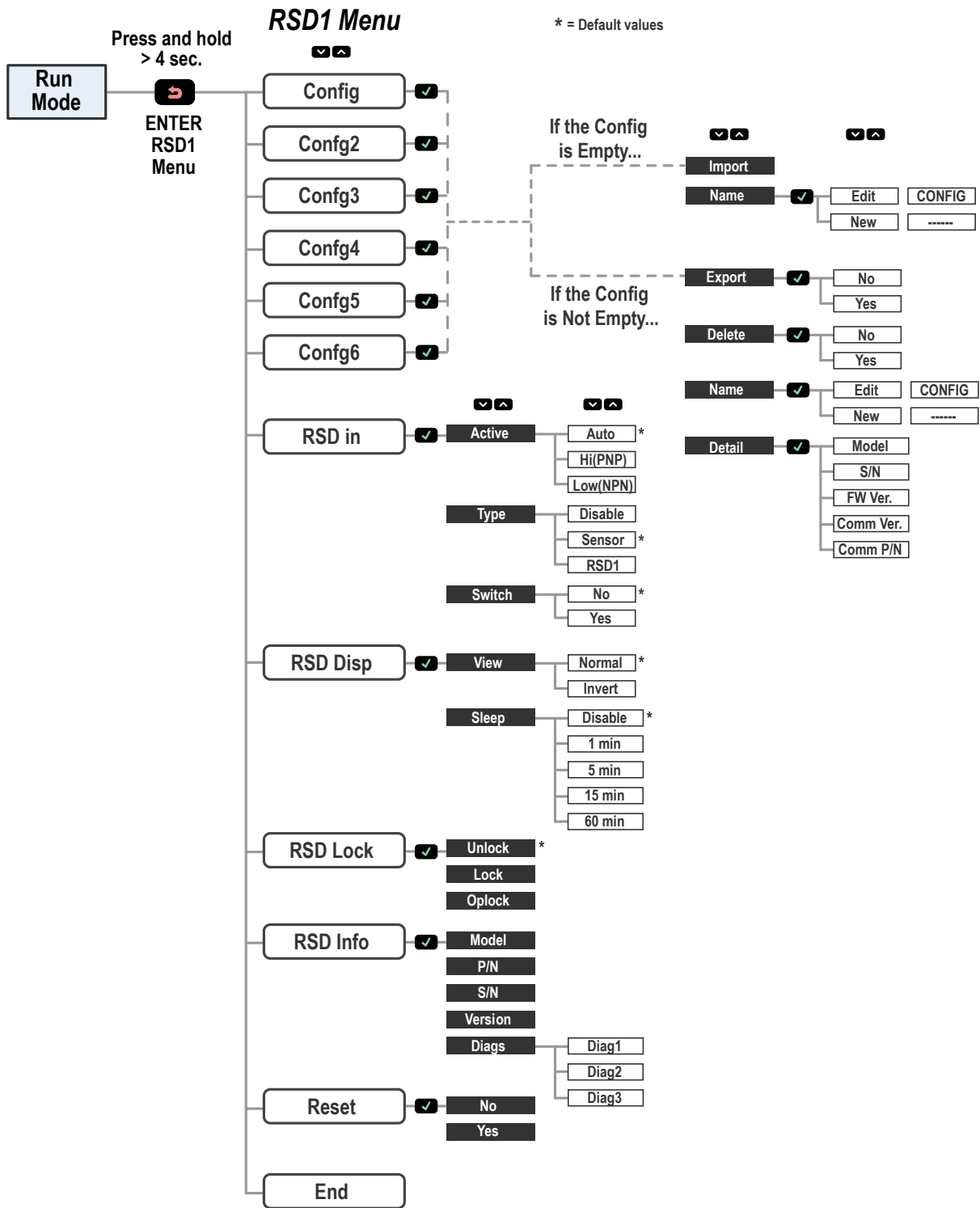

Figure 12. RSD1 Full Menu Map

## 6 Accessories

### 6.1 Brackets

#### DIN-35-..

35 mm DIN Rail

Model	Length
DIN-35-70	70
DIN-35-105	105
DIN-35-140	140

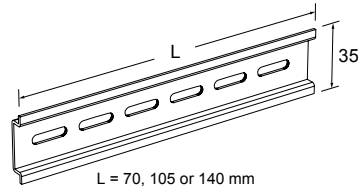

Hole center spacing: 35.1

Hole size: 25.4 x 5.3

All measurements are listed in millimeters, unless noted otherwise.

### 6.2 Cordsets

The following cordsets can be used to extend the distance between the sensor and RSD1.

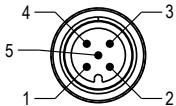
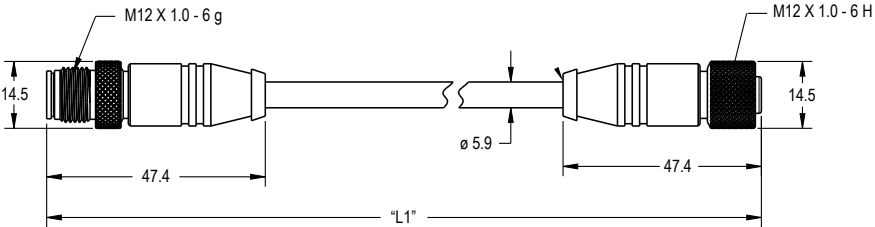
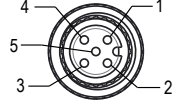
5-Pin Male Threaded and 5-Pin Female Quick Disconnect M12/Euro-Style Cordset—Double Ended			
Model	Length "L1"	Style	Pinout
MQDEC3-503SS	0.31 m (1 ft)	Female Straight/ Male Straight	<p>Male</p>  <p>1 = Brown 2 = White 3 = Blue 4 = Black 5 = Grey</p>
MQDEC3-506SS	1.83 m (6 ft)		
MQDEC3-515SS	4.58		
MQDEC3-530SS	9.20		
			<p>Female</p>  <p>1 = Brown 2 = White 3 = Blue 4 = Black 5 = Grey</p>

The following cordsets can be used to connect the RSD1 to a 4-pin sensor.

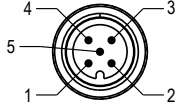
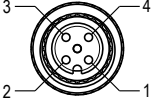
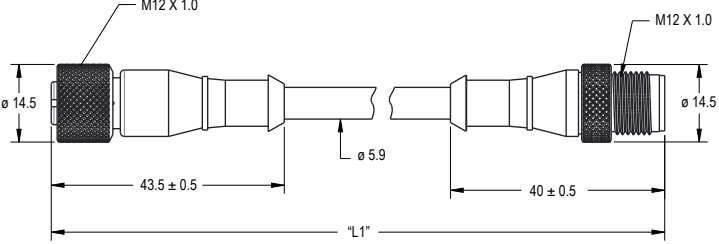

4-Pin Female and 5-Pin Male Threaded M12/Euro-Style Cordset—Double Ended			
Model	Length "L1"	Style	Pinout
MQDC-4501SS	0.31 m (1 ft)	Female Straight/ Male Straight	<p>Male</p>  <p>1 = Brown 2 = Not Used 3 = Blue 4 = Black 5 = White</p> <p>Female</p>  <p>1 = Brown 2 = White 3 = Blue 4 = Black</p>
MQDC-4506SS	1.83 m (6 ft)		
			

The following cordsets can be used to connect the RSD1 to a control system using the white wire (pin-2) as remote input for Remote TEACH, Laser Off, Laser On.

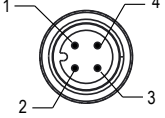
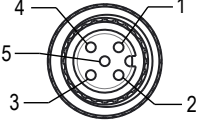
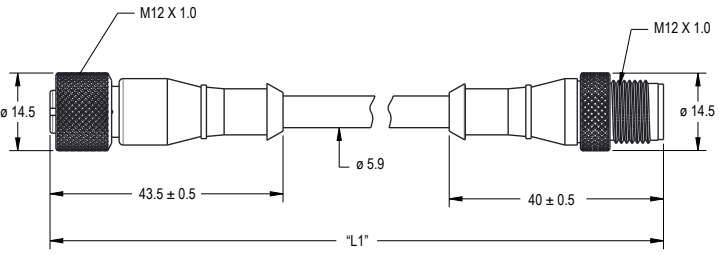
4-Pin Male and 5-Pin Female Threaded M12/Euro-Style Cordsets—Double Ended			
Model	Length "L1"	Style	Pinout
MQDC-5401SS	0.31 m (1 ft)	Female Straight/ Male Straight	<p>Male</p>  <p>1 = Brown 2 = White 3 = Blue 4 = Black</p> <p>Female</p>  <p>1 = Brown 2 = Not Used 3 = Blue 4 = Black 5 = White</p>
MQDC-5406SS	1.83 m (6 ft)		
			

# 7 Troubleshooting

## 7.1 Errors

Error Message	Description	Solution
<b>NoSensor Found...</b>	No sensor connected	Connect a sensor
<b>Fail NoSensor</b>	No sensor connected	Connect a sensor
<b>Fail NotMatch</b>	Sensor version mismatch—the sensor version and part number do not match the configuration being exported	Use a different sensor or select a different export configuration
<b>Fail TryAgain</b>	Import or export failure	Try the import/export again

# 8 Contact Us

## Corporate Headquarters

**Address:**  
Banner Engineering Corporate  
9714 Tenth Avenue North  
Minneapolis, Minnesota 55441, USA

**Phone:** +1 763 544 3164  
**Website:** [www.bannerengineering.com](http://www.bannerengineering.com)

## Europe

**Address:**  
Banner Engineering EMEA  
Park Lane, Culliganlaan 2F, bus 3  
1831 Diegem, Belgium

**Phone:** +32 (0)2 456 0780  
**Website:** [www.bannerengineering.com](http://www.bannerengineering.com)  
**Email:** [mail@bannerengineering.com](mailto:mail@bannerengineering.com)

## Turkey

**Address:**  
Banner Engineering Elk. San. Ve Tic. Ltd. Şti.  
Şerifali Mah. Münevver Sok. Ekomed Plaza No:10 Kat:4  
Ümraniye / İstanbul, Türkiye

**Phone:** +90 216 688 8282  
**Website:** [www.bannerengineering.com](http://www.bannerengineering.com)  
**Email:** [turkey@bannerengineering.com.tr](mailto:turkey@bannerengineering.com.tr)

## India

**Address:**  
Banner Engineering India Pune Head Quarters  
Office No. 1001, 10th Floor Sai Capital, Opp. ICC Senapati Bapat Road  
Pune 411016, India

**Phone:** +91 (0) 206 640 5624  
**Website:** [www.bannerengineering.com](http://www.bannerengineering.com)  
**Email:** [salesindia@bannerengineering.com](mailto:salesindia@bannerengineering.com)

## Mexico

**Address:**  
Banner Engineering de Mexico Monterrey Head Office  
Edificio VAO Av. David Alfaro Siqueiros No.103 Col. Valle Oriente C.P.66269  
San Pedro Garza Garcia, Nuevo Leon, Mexico

**Phone:** +52 81 8363 2714 or 01 800 BANNERE (toll free)  
**Website:** [www.bannerengineering.com](http://www.bannerengineering.com)  
**Email:** [mexico@bannerengineering.com](mailto:mexico@bannerengineering.com)

## Brazil

**Address:**  
Banner do Brasil  
Rua Barão de Teffé nº 1000, sala 54  
Campos Eliseos, Jundiaí - SP, CEP.: 13208-761, Brasil

**Phone:** +55 11 2709 9880  
**Website:** [www.bannerengineering.com](http://www.bannerengineering.com)  
**Email:** [brasil@bannerengineering.com](mailto:brasil@bannerengineering.com)

## China

**Address:**  
Banner Engineering Shanghai Rep Office  
Xinlian Scientific Research Building Level 12, Building 2  
1535 Hongmei Road, Shanghai 200233, China

**Phone:** +86 212 422 6888  
**Website:** [www.bannerengineering.com](http://www.bannerengineering.com)  
**Email:** [sensors@bannerengineering.com.cn](mailto:sensors@bannerengineering.com.cn)

## Japan

**Address:**  
Banner Engineering Japan  
Cent-Urban Building 305 3-23-15 Nishi-Nakajima Yodogawa-Ku  
Osaka 532-0011, Japan

**Phone:** +81 (0)6 6309 0411  
**Website:** [www.bannerengineering.com](http://www.bannerengineering.com)  
**Email:** [mail@bannerengineering.co.jp](mailto:mail@bannerengineering.co.jp)

Taiwan

---

**Address:**

Banner Engineering Taiwan  
8F-2, No. 308 Section 1, Neihu Road  
Taipei 114, Taiwan

**Phone:** +886 (0)2 8751 9966

**Website:** [www.bannerengineering.com](http://www.bannerengineering.com)

**Email:** [info@bannerengineering.com.tw](mailto:info@bannerengineering.com.tw)

## 9 Banner Engineering Corp. Limited Warranty

Banner Engineering Corp. warrants its products to be free from defects in material and workmanship for one year following the date of shipment. Banner Engineering Corp. will repair or replace, free of charge, any product of its manufacture which, at the time it is returned to the factory, is found to have been defective during the warranty period. This warranty does not cover damage or liability for misuse, abuse, or the improper application or installation of the Banner product.

**THIS LIMITED WARRANTY IS EXCLUSIVE AND IN LIEU OF ALL OTHER WARRANTIES WHETHER EXPRESS OR IMPLIED (INCLUDING, WITHOUT LIMITATION, ANY WARRANTY OF MERCHANTABILITY OR FITNESS FOR A PARTICULAR PURPOSE), AND WHETHER ARISING UNDER COURSE OF PERFORMANCE, COURSE OF DEALING OR TRADE USAGE.**

This Warranty is exclusive and limited to repair or, at the discretion of Banner Engineering Corp., replacement. **IN NO EVENT SHALL BANNER ENGINEERING CORP. BE LIABLE TO BUYER OR ANY OTHER PERSON OR ENTITY FOR ANY EXTRA COSTS, EXPENSES, LOSSES, LOSS OF PROFITS, OR ANY INCIDENTAL, CONSEQUENTIAL OR SPECIAL DAMAGES RESULTING FROM ANY PRODUCT DEFECT OR FROM THE USE OR INABILITY TO USE THE PRODUCT, WHETHER ARISING IN CONTRACT OR WARRANTY, STATUTE, TORT, STRICT LIABILITY, NEGLIGENCE, OR OTHERWISE.**

Banner Engineering Corp. reserves the right to change, modify or improve the design of the product without assuming any obligations or liabilities relating to any product previously manufactured by Banner Engineering Corp. Any misuse, abuse, or improper application or installation of this product or use of the product for personal protection applications when the product is identified as not intended for such purposes will void the product warranty. Any modifications to this product without prior express approval by Banner Engineering Corp will void the product warranties. All specifications published in this document are subject to change; Banner reserves the right to modify product specifications or update documentation at any time. Specifications and product information in English supersede that which is provided in any other language. For the most recent version of any documentation, refer to: [www.bannerengineering.com](http://www.bannerengineering.com).