

Rev	AWO #	Description	Date	Appr
-		RELEASED	7/02/08	

APPROVED: _____
 DATE: _____ TITLE: _____

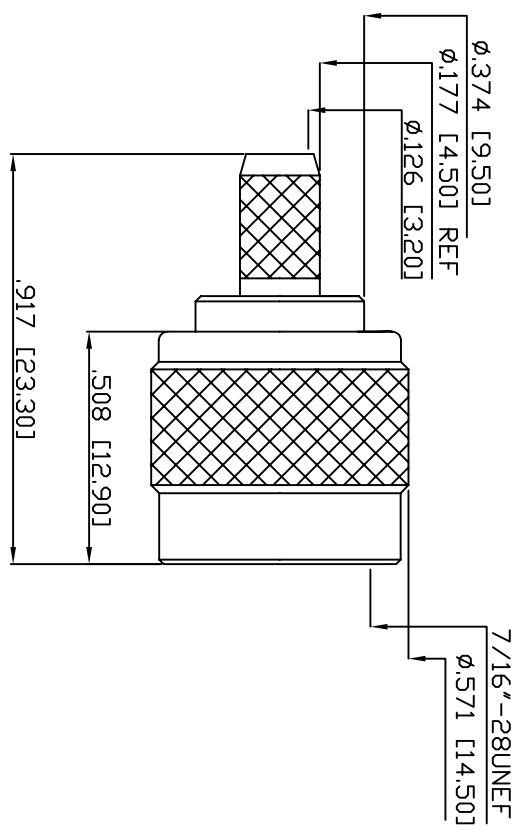

NO	DESCRIPTION	MATERIAL	Q'TY	FINISH
8	INSULATION	TEFLON	1	NONE
7	SHELL	BRASS	1	NICKEL 100µ" MIN.
6	GASKET	RUBBER	1	NONE
5	WASHER	BRASS	1	NICKEL 100µ" MIN.
4	WASHER	BRASS	1	NICKEL 100µ" MIN.
3	BODY	BRASS	1	NICKEL 100µ" MIN.
2	CENTER CONTACT	BRASS	1	GOLD
1	CRIMP FERRULE	BRASS	1	NICKEL 100µ" MIN.

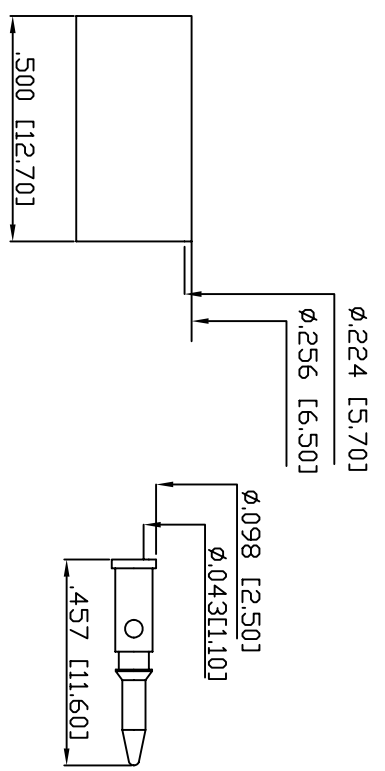
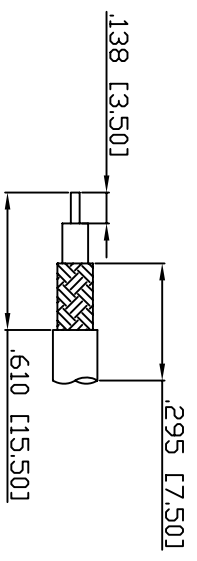

STRIPPING DIMENSION

SPECIFICATIONS:

Electrical:
 Nominal Impedance: 50 ohms
 Frequency range: 0-4 GHz
 Maximum peak voltage: 500V
 Insulation resistance: 5000 Mohm min @ 500 VDC
 Dielectric withstanding voltage: 1500 VAC rms

Environmental:
 Lead free, ROHS compliant.



UNLESS OTHERWISE SPECIFIED
 ALL DIMENSIONS ARE INCHES [MM]
 TOLERANCES: EXCEPT AS NOTED
 INCHES HOLES

.X	± .10	Ø.X	± .10
.XX	± .020	Ø.XXX	± .015
.XXX	± .015	Ø.XXXX	± .010

ADAM TECH

909 Rahway Avenue, Union, NJ 07083
 Phone: 908-687-5000 Fax: 908-687-5710

TNC STRAIGHT PLUG CRIMP, 142U, 50 OHM

APPROVALS	DATE
DRAWN	DY
CHECKED	
APPROVED	

SIZE	PART NO.	REV.
X	RF7-01-D-02-50	
REF:	SCALE: NTS	SHEET 1 OF 1