



S3525

CMOS IC

PC POWER SUPPLY SUPERVISOR

DESCRIPTION

The UTC **S3525** is specially designed for switching power supply system. it provides protection circuits, power good output (PGO) indicator, fault protection output (FPOB) and a PSONB control.

The protection circuits include over voltage protection (OVP), under voltage protection (UVP) and over current protection (OCP) monitoring for system voltages and currents.

When 3.3V, 5V or 12V voltage is decreasing to 2.68V, 4.3V and 9.9V respectively, the under voltage protection (UVP) function will be enabled. FPOB will be set to high to turn off the PWM controller IC. Toggling the PSONB from low to high will reset the fault protection latch.

The voltage difference across external current shunt is used for OCP functions. An external resistor can be used to adjust protection threshold.

The power supply is turned on after 38mS delay time when PSONB signal is set from high to low. To turn off power supply, PSONB signal is set from low to high with the delay time 38mS. The PGI circuitry provides a power-down warning signal for PGO. When PGI input is lower than the internal 1.20V reference voltage, PGO signal is pulled low.

FEATURES

- * OVP/UVP monitors 3.3V, 5V, 12V input voltage level.
- * OCP monitors I_{S33} , I_{S5} , I_{S12} input current sense.
- * Fault protection output (FPOB) with Open Drain Output stage.
- * Power good output (PGO) with Open Drain Output stage.
- * 38ms de-bounce time for PSONB input signal.
- * 300ms time delay from PGI to PGO.
- * 2.4ms time delay for PSONB to turn off FPOB.

ORDERING INFORMATION

Ordering Number		Package	Packing
Lead Free Plating	Halogen Free		
S3525L-D14-T	S3525G-D14-T	DIP-14	Tube
S3525L-S14-R	S3525G-S14-R	SOP-14	Tape Reel
S3525L-S14-T	S3525G-S14-T	SOP-14	Tube

<p>S3525G-D14-T</p> <p>(1)Packing Type (2)Package Type (3)Halogen Free</p>	<p>(1) R: Tape Reel, T: Tube (2) D14: DIP-14, S14: SOP-14 (3) G: Halogen Free, L: Lead Free Plating</p>
--	---

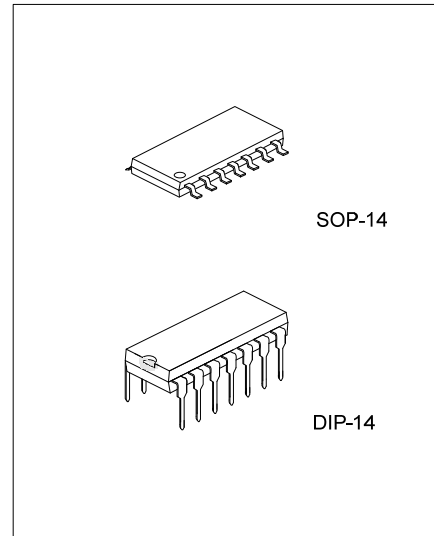

■ PIN ASSIGNMENT

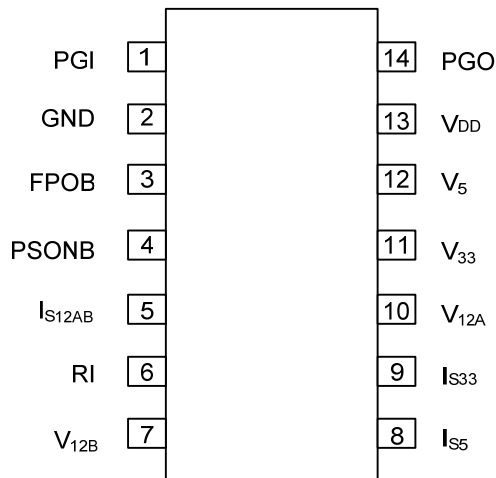

■ FUNCTION DESCRIPTION

PGI	PSONB	UV&OC Protection	OV Protection	FPOB	PGO
PGI<1.2V	L	No	No	L	L
PGI<1.2V	L	No	Yes	H	L
PGI<1.2V	L	Yes	No	L	L
PGI<1.2V	L	Yes	Yes	H	L
PGI>1.2V	L	No	No	L	H
PGI>1.2V	L	No	Yes	H	L
PGI>1.2V	L	Yes	No	H	L
PGI>1.2V	L	Yes	Yes	H	L
X	H	X	X	H	L

Note: FPOB=L means: fault is not latched. FPOB=H means: fault is latched

PGO=L means: fault. PGO=H means: No fault

X=do not care

■ PIN DESCRIPTIONS

PIN NO.	PIN NAME	TYPE	DESCRIPTION
1	PGI	Input	Power Good Input. For ATX SMPS, it detects AC line voltage through the main transformer.
2	GND	Supply	Ground
3	FPOB	Output	Fault Protection Output. Output signal to control the primary PWM IC through an opto-coupler. When FPOB is low, the PWM IC is enabled.
4	PSONB	Input	Remote On/Off logic input from CPU or main-board. The power supply will be turned on/off after 38mS delay.
5	IS12AB	Input	12V _{AB} over current protection.
6	RI	Input	Reference setting. One external resistor Ri connected between RI and GND pin will determine a reference current, I _{REF} = 1.20/Ri, for OCP programming.
7	V12B	Input	12V over/under voltage protection.
8	IS5	Input	5V over current protection.
9	IS33	Input	3.3V over current protection
10	V12A	Input	12V over/under voltage protection.
11	V33	Input	3.3V over/under voltage protection
12	V5	Input	5V over/under voltage protection.
13	VDD	Supply	Power supply.
14	PGO	Output	Power good logic output, 0 or 1(open-drain). Power good=1 means that the power supply is good for operation. The power good delay is 300mS.

■ BLOCK DIAGRAM

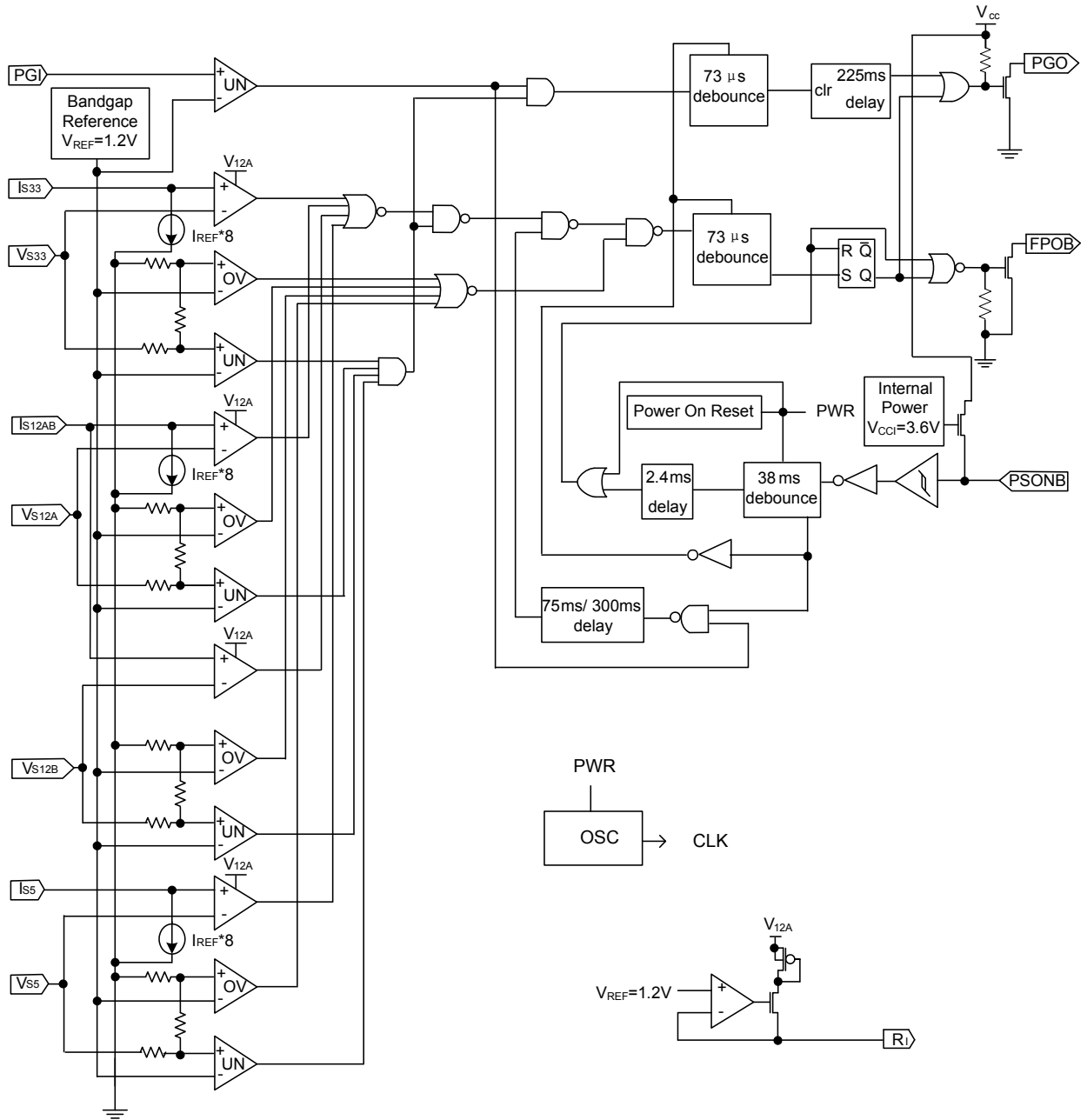

■ ABSOLUTE MAXIMUM RATINGS

PARAMETER		SYMBOL	RATINGS	UNIT
Supply Voltage, V_{DD} , V_{12A}			-0.3 ~ 16	V
Input Voltage	$V_5, V_{33}, PSONB, I_{S5}, I_{S33}$	V_{IN}	-0.3 ~ 7	V
	I_{S12AB}, V_{12B}		-0.3 ~ 16	V
	PGI		-0.3 ~ $V_{DD}+0.3$	V
Output Voltage	FPOB	V_{OUT}	-0.3 ~ 7	V
	PGO		-0.3 ~ 7	V
Operating Temperature		T_{OPR}	-40 ~ +125	°C
Storage Temperature		T_{STG}	-55 ~ +150	°C

Note Absolute maximum ratings are those values beyond which the device could be permanently damaged. Absolute maximum ratings are stress ratings only and functional device operation is not implied.

■ RECOMMENDED OPERATING CONDITIONS

PARAMETER		SYMBOL	MIN	TYP	MAX	UNIT
Supply Voltage V_{DD}		V_{DD}	4	12	15	V
Supply Voltage V_{CC2}			9.5	12	15	V
Input Voltage	$V_5, V_{33}, PGI, PSONB$	V_{IN}			7	V
	V_{12A}, V_{12B}				15	V
Output Voltage	FPOB	V_{OUT}			7	V
	PGO				7	V
Output Sink Current	FPOB	$I_{O(SINK)}$			30	mA
	PGO				10	mA
RI Output Current		$I_{O(RI)}$	10		65	uA
Supply Voltage Rising Time (V_{DD})		t_R	1			ms

■ ELECTRICAL CHARACTERISTICS ($T_a=25^\circ\text{C}$ and $V_{DD}=5\text{V}$ and $V_{12A}=12\text{V}$)

PARAMETER	SYMBOL	TEST CONDITIONS	MIN	TYP	MAX	UNIT
Over Voltage Detection						
Over Voltage Threshold	V_{12A}, V_{12B}		13.2	13.8	14.4	V
	V_5		5.7	6.1	6.5	V
	V_{33}		3.7	3.9	4.1	V
Low Level Output Voltage (FPOB)	V_{OL}	$I_{SINK}=10\text{mA}$ $I_{SINK}=30\text{mA}$			0.3 0.7	V
Output Leakage Current (FPOB)	I_{LEAK}	$V_{(FPOB)}=5\text{V}$			5	uA
PSONB						
High-Level Input Voltage	V_{IH}		2			V
Low-Level Input Voltage	V_{IL}				0.8	V
Input Pull-up Current	I_{IN}	PSONB=0V		120		uA
PGI and PGO						
Under Voltage Threshold	V_{12A}, V_{12B}		9.5	10	10.5	V
	V_5		4.1	4.30	4.47	V
	V_{33}		2.55	2.69	2.83	V
Input Threshold Voltage (PGI)	$V_{I(THD)}$		1.16	1.20	1.24	V
Low Level Output Voltage (PGO)	V_{OL}	$I_{SINK}=10\text{mA}$			0.4	V
Output Leakage Current (PGO)	I_{LEAK}	PGO=5V			5	uA

■ ELECTRICAL CHARACTERISTICS (Cont.)

PARAMETER	SYMBOL	TEST CONDITIONS	MIN	TYP	MAX	UNIT
SWITCHING CHARACTERISTICS						
PSONB ON(PSONB Low to FPOB Low)	$T_{(PSONB\ ON)}$	$V_{DD}=5V$	32	38	62	ms
PSONB OFF(PSONB Hi to PGO Low)	$T_{(PSONB\ OFF)}$	$V_{DD}=5V$	32	38	62	ms
PGI to PGO Delay Time	T_{PG}	$V_{DD}=5V$	200	300	490	ms
Timing PGO Low to FPOB high	T_{PSOFF}	$V_{DD}=5V$	2.0	2.4	4	ms
UVD/OCD Turn on Delay Time	T_{UVP1}	FPOB=Low & PGI > 1.2V	65	75	122	ms
	T_{UVP2}	FPOB=Low & PGI < 1.2V	260	300	488	ms
Noise Deglitch Time	t_{g1}		63	75	120	μs
Noise Deglitch Time for Latch	t_{g2}		63	75	120	μs
TOTAL DEVICE						
Low Voltage	V_{DD}			3.0		V
Supply Current	I_{DD}	PSONB=5V			1	mA

■ APPLICATION INFORMATION

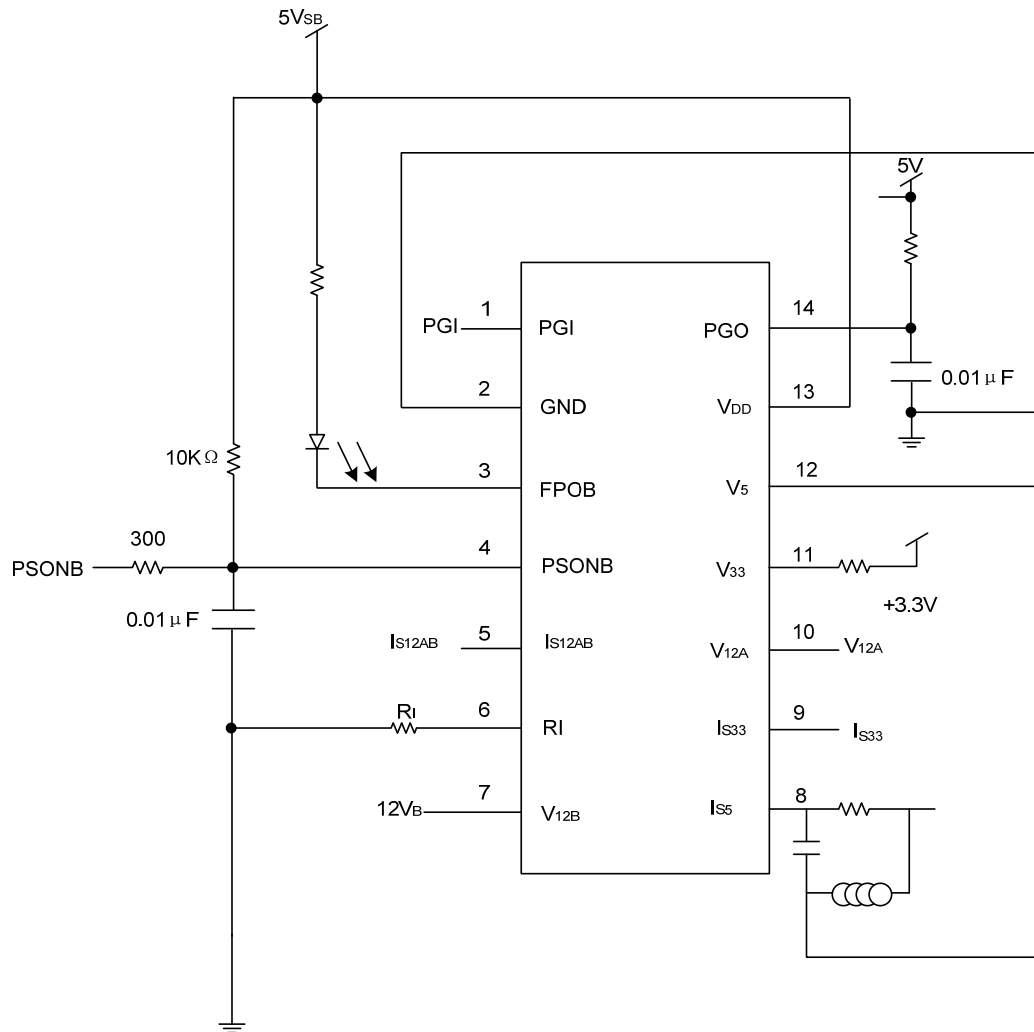

■ APPLICATION INFORMATION

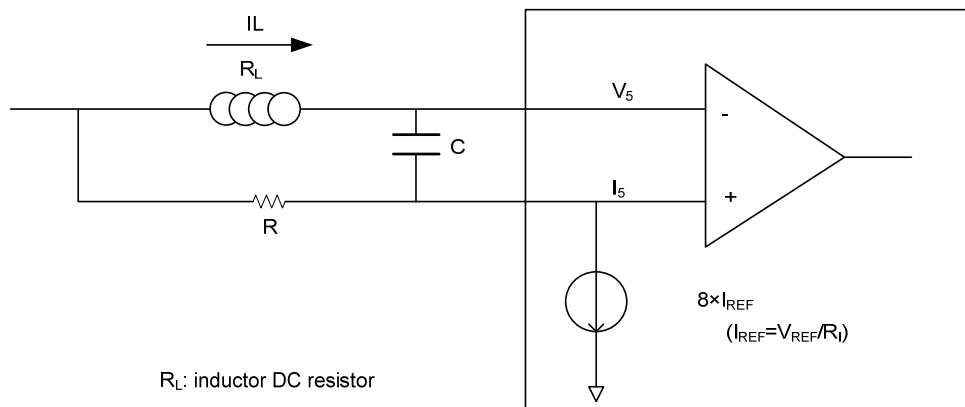

If $I_L * R_L > (8 * I_{REF}) * R$, then OCP active.

And the capacitor C is used to avoid power on fail or dynamic load fail. We suggest $C > 1\mu F$.

EX: How to select the resistor of R? Assume $R_1=30K\Omega$, $R_L=3m\Omega$, $OCP=20A$.

$$\begin{aligned} \text{Sol: } R &= (I_L * R_L) / (8 * I_{REF}) \\ &= (20A * 3m\Omega) / \{8 * (1.2V / 30K\Omega)\} \\ &= 187.5\Omega \end{aligned}$$

■ TYPICAL TIMMING DIAGRAM

1) PGI (UNDER-VOLTAGE):

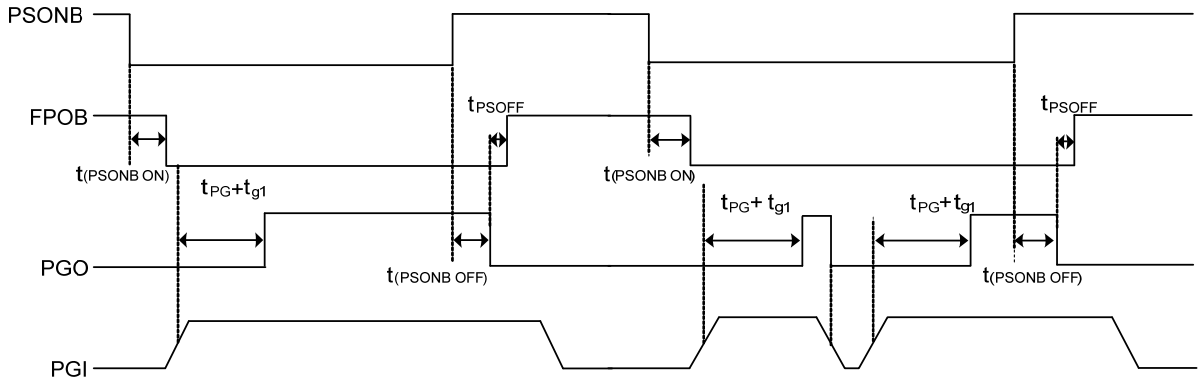

2) V_{33} , V_5 , V_{12A} , V_{12B} (UNDER-VOLTAGE) or I_{S33} , I_{S5} , I_{S12AB} (OVER-CURRENT):

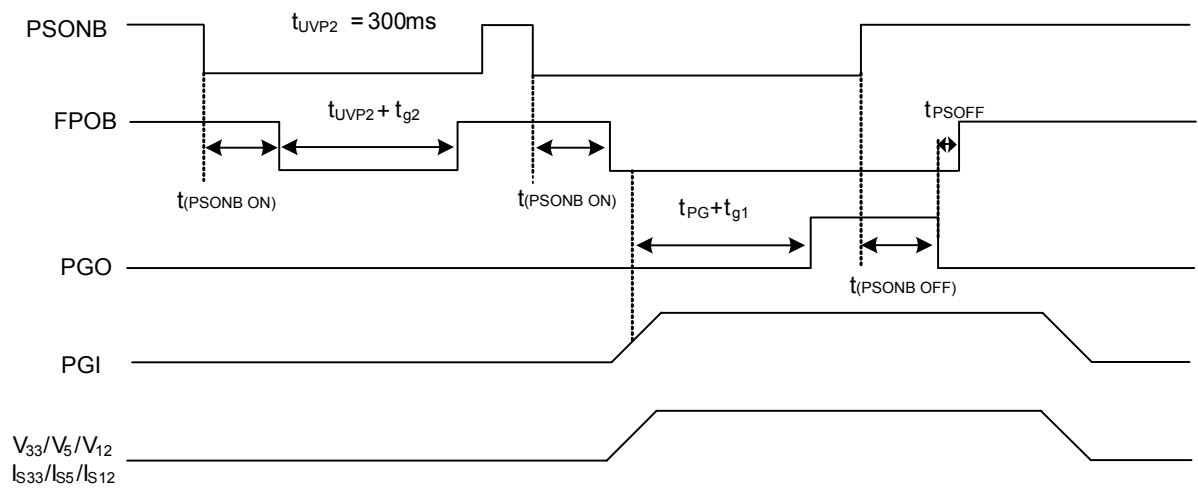
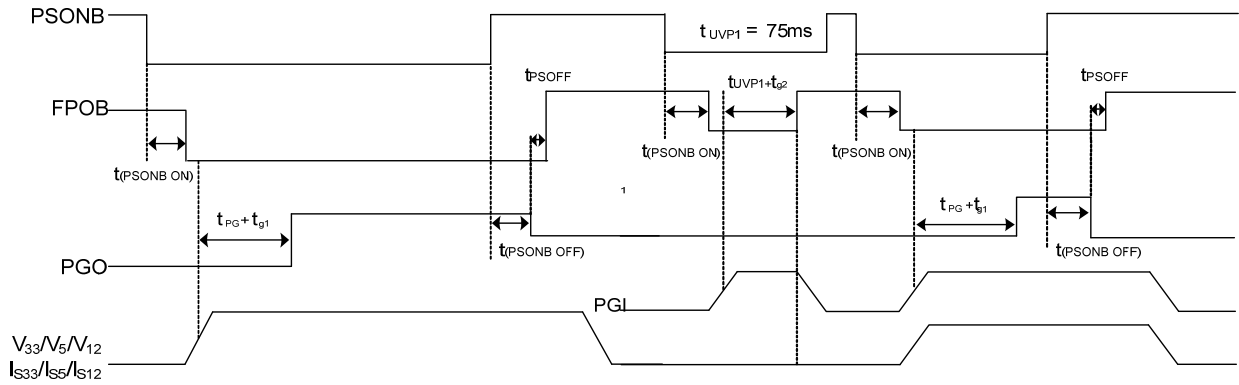

■ TYPICAL TIMMING DIAGRAM(Cont.)

3) V_{33} , V_5 , V_{12A} , V_{12B} (OVER-VOLTAGE).

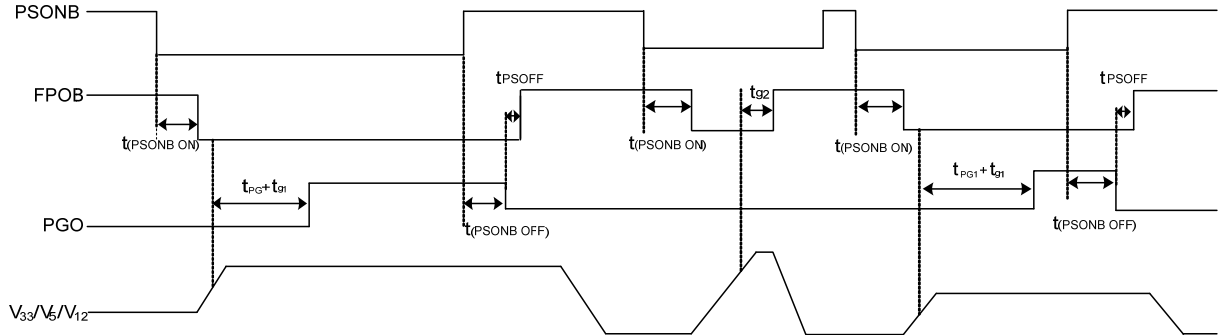

UTC assumes no responsibility for equipment failures that result from using products at values that exceed, even momentarily, rated values (such as maximum ratings, operating condition ranges, or other parameters) listed in products specifications of any and all UTC products described or contained herein. UTC products are not designed for use in life support appliances, devices or systems where malfunction of these products can be reasonably expected to result in personal injury. Reproduction in whole or in part is prohibited without the prior written consent of the copyright owner. The information presented in this document does not form part of any quotation or contract, is believed to be accurate and reliable and may be changed without notice.