

PRODUCT DATA DRAWING

REVISION HISTORY			
REV	DESCRIPTION	DATE	APPROVED
-	DCN 47174	02/18	GPF
A	REV. DCN 47420	05/03/18	STW

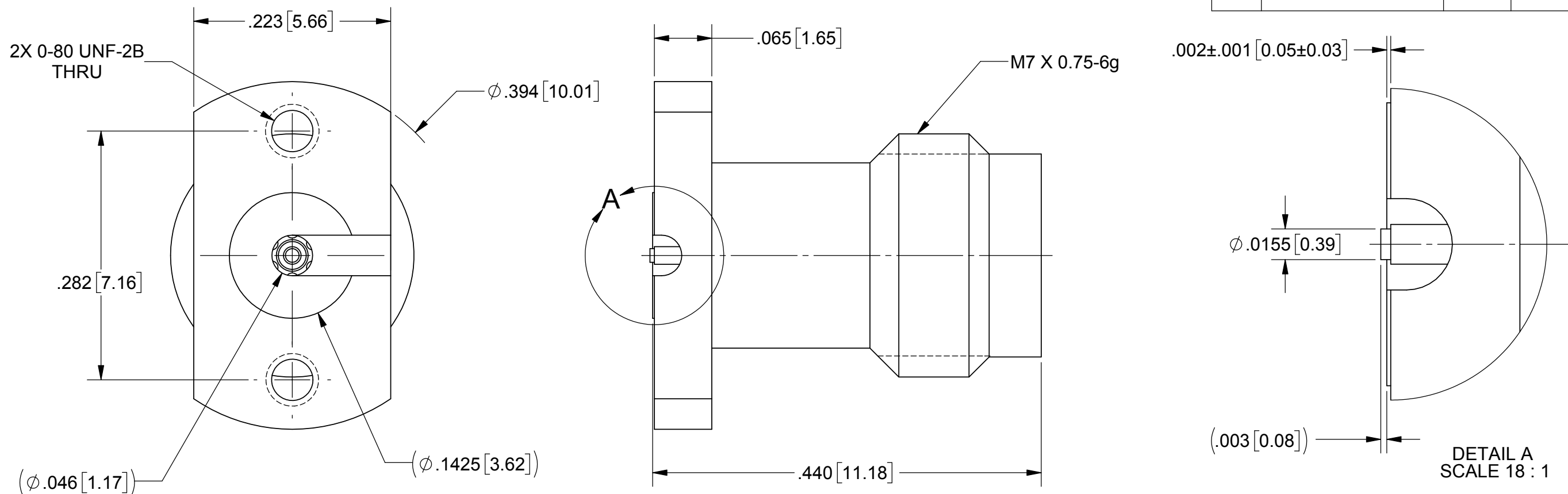

MATERIAL:
BODY & INSERT: STAINLESS STEEL PER AMS 5640, ALLOY UNS S30300, TYPE 1 OR ASTM A582, TYPE 303, CONDITION A.
CONTACT: BERYLLIUM COPPER PER ASTM B196, ALLOY No. UNS C17300, TD04.
INSULATOR: PEI (ULTEM 1000) PER ASTM D5205.
SCREWS: 300 SERIES STAINLESS STEEL.
FINISH:

BODY, INSERT & SCREWS: PASSIVATED PER AMS 2700.
CONTACT: GOLD PER ASTM B488, TYPE II, CODE C, CLASS .76, OVER NICKEL PER AMS-QQ-N-290, CLASS 1, .00005" MIN.

PERFORMANCE:
IMPEDANCE: 50 OHMS
FREQ. RANGE: DC TO 67.0 GHz
VSWR: 1.35:1 DC TO 67.0 GHz
INSERTION LOSS: .05 X SQRT(F(F IN GHz))

NOTES:
 1. FOR RECOMMENDED FOOTPRINT FOR YOUR PCB, ONTACT SV MICROWAVE SALES DEPARTMENT (sales@svmicro.com, 561-840-1800)

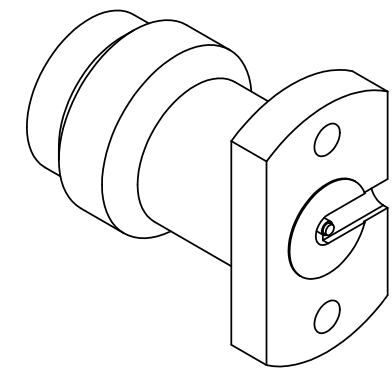
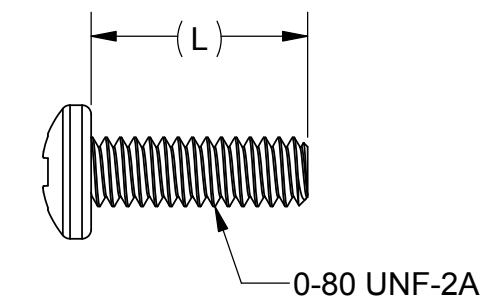

SV P/N	DESCRIPTION	PCB THICKNESS	(L)
SF3321-60024-1S	INCL. 2 EA (.188) SCREWS	.016 TO .123	.188
SF3321-60024-2S	INCL. 2 EA (.250) SCREWS	.078 TO .185	.250
SF3321-60024-3S	INCL. 2 EA (.438) SCREWS	.266 TO .373	.438
SF3321-60024	NO SCREWS	.005 TO .373	N/A

MATERIAL: SEE NOTES	DIMENSIONS ARE IN INCHES TOLERANCES: FRACTIONAL: ±1/64 ANGULAR: X° ±1'0" X"X' ±15'	UNLESS OTHERWISE SPECIFIED 1) ALL DIMENSIONS ARE IN INCHES (MILLIMETERS) 2) ALL DIMENSIONS ARE AFTER PLATING. 3) BREAK CORNERS & EDGES .005 R. MAX. 4) CHAM. 1ST & LAST THREADS. 5) SURFACE ROUGHNESS 63-MIL-STD-10. 6) DIA.'S ON COMMON CENTERS TO BE CONCENTRIC WITHIN .005 T.I.R. 7) REMOVE ALL BURRS	SV Microwave, Inc. 2400 Centrepark West Drive, Suite 100 West Palm Beach, FL 33409 TITLE: 1.85MM JACK 2 HOLE FLANGE COMPRESSION MOUNT (67 GHz) FOR CPW/MICROSTRIP SIZE: B CAGE CODE: 95077 DWG. NO.: SF3321-60024-XS SCALE: 8:1
FINISH: SEE NOTES	DECIMAL: X ±.030 .XX ±.010 .XXX ±.005	INTERPRET DIMENSIONS AND TOLERANCES PER ASME Y14.5M - 1994	
SURFACE AREA: N/A	THIRD ANGLE PROJECTION	DRAWN: JMC 03/10/16 CHECKED: STW 03/11/16 APPROVED: STW 03/11/16	SHEET 1 OF 1