

**PLEASE CHECK WWW.MOLEX.COM FOR LATEST PART INFORMATION**

**Part Number:** [0743370055](#)  
**Status:** **Active**  
**Description:** 0.80mm (.031") Pitch Ultra+™ VHDCI Receptacle, Stacked, Right Angle, Enhanced Shield, Press-Fit PCB Retention Option, 136 Circuits, with Screw Locks and Cover

**Documents:**

[3D Model](#) [Product Specification PS-71425-9999 \(PDF\)](#)  
[Drawing \(PDF\)](#) [RoHS Certificate of Compliance \(PDF\)](#)

**Agency Certification**

CSA LR19980  
 UL E29179

**General**

Product Family I/O Connectors  
 Series [74337](#)  
 Application Wire-to-Board  
 Comments Without Top Cover  
 Component Type Receptacle  
 Product Name SCSI+, VHDCI  
 Type N/A

**Physical**

Boot Color N/A  
 Circuits (Loaded) 136  
 Circuits (maximum) 136  
 Color - Resin Black  
 Durability (mating cycles max) 500  
 Flammability 94V-0  
 Gender Female  
 Lock to Mating Part Yes  
 Material - Metal Brass  
 Material - Plating Mating Tin  
 Material - Plating Termination Tin  
 Material - Resin High Temperature Thermoplastic  
 Number of Rows 4  
 Orientation Right Angle  
 PC Tail Length (in) 0.143 In  
 PC Tail Length (mm) 3.62 mm  
 PCB Locator Yes  
 PCB Retention Yes  
 PCB Thickness Recommended (in) 0.093 In  
 PCB Thickness Recommended (mm) 2.36 mm  
 Packaging Type Tray  
 Panel Mount Yes  
 Pitch - Mating Interface (in) 0.031 In  
 Pitch - Mating Interface (mm) 0.80 mm  
 Pitch - Term. Interface (in) 0.031 In  
 Pitch - Term. Interface (mm) 0.80 mm  
 Plating min: Mating (µin) 40  
 Plating min: Mating (µm) 1.00  
 Plating min: Termination (µin) 40  
 Plating min: Termination (µm) 1.00  
 Polarized to Mating Part Yes  
 Polarized to PCB Yes  
 Ports 2

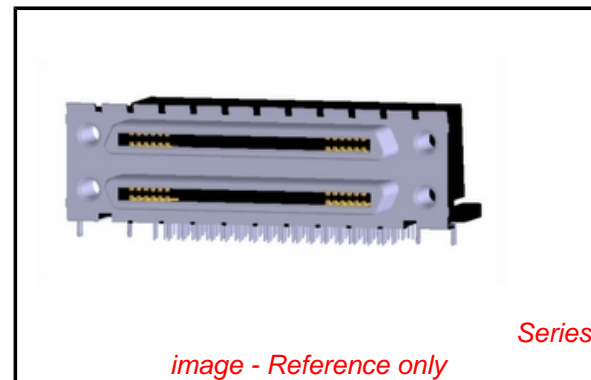

**EU RoHS**

**RoHS Compliant by Exemption**

**REACH SVHC**

Not Reviewed

**Halogen-Free**

**Status**

**Not Reviewed**

**Need more information on product environmental compliance?**

Email [productcompliance@molex.com](mailto:productcompliance@molex.com)  
 For a multiple part number RoHS Certificate of Compliance, [click here](#)

Please visit the [Contact Us](#) section for any non-product compliance questions.

**China RoHS**



**Search Parts in this Series**

[74337Series](#)

**Mates With**

[71425](#) Ultra+™ VHDCI Plug Kit

Surface Mount Compatible (SMC)	Yes
Temperature Range - Operating	-55°C to +85°C
Termination Interface: Style	Through Hole
Waterproof / Dustproof	No
Wire Size AWG	N/A

### **Electrical**

Current - Maximum per Contact	0.5A
Grounding to Panel	Screw Hole
Shield Type	Full Shield
Shielded	Yes
Voltage - Maximum	30V AC (RMS)/DC

### **Solder Process Data**

Duration at Max. Process Temperature (seconds)	40
Lead-free Process Capability	Wave Capable (TH only)
Max. Cycles at Max. Process Temperature	3
Process Temperature max. C	245

### **Material Info**

#### **Reference - Drawing Numbers**

Packaging Specification	PK-74337-001
Product Specification	PS-71425-9999
Sales Drawing	SD-74337-014

This document was generated on 05/28/2010

**PLEASE CHECK [WWW.MOLEX.COM](http://WWW.MOLEX.COM) FOR LATEST PART INFORMATION**

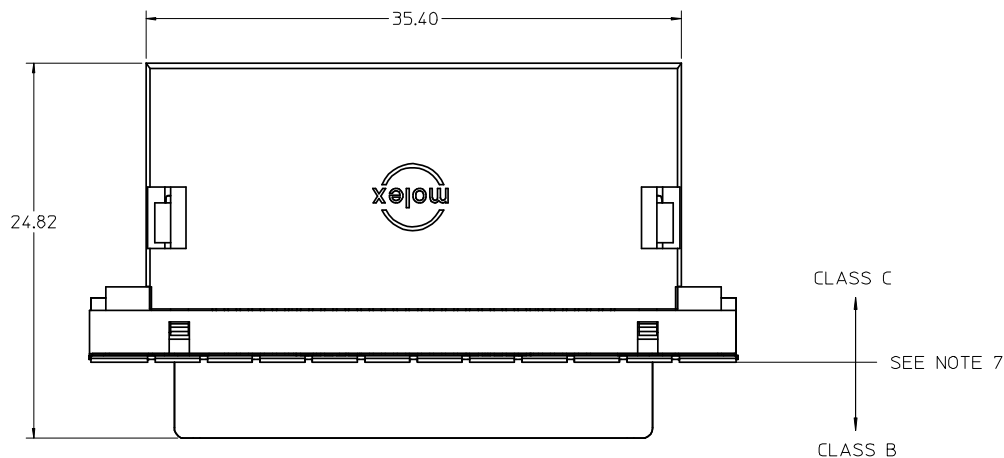

NOTES:

1. MATERIALS:  
HOUSING, COVER, AND TAIL ALIGNER: HIGH TEMPERATURE THERMOPLASTIC, UL94, V-0 RATED, COLOR: BLACK  
TERMINAL: PHOSPHOR BRONZE ALLOY  
BRACKET: BRASS  
SHELL: STEEL  
INSERT: BRASS
2. FINISHES:  
TERMINAL: 0.05-0.25 MICROMETERS GOLD FLASH IN CRITICAL AREA OVER 0.75 MICROMETERS MINIMUM PALLADIUM NICKEL IN CRITICAL AREA, 1.87 MICROMETERS MINIMUM TIN IN SOLDER TAIL AREA, ALL OVER NICKEL.  
BRACKET: 5.0 MICROMETERS MINIMUM BRIGHT TIN.  
SHIELD: 3.81 MICROMETERS MINIMUM BRIGHT TIN OVER 1.27 MICROMETERS MINIMUM NICKEL OVER COPPER FLASH (OPTIONAL).  
INSERT: 2.54 MICROMETERS MINIMUM NICKEL.
3. PRODUCT SPECIFICATION: PS-71425-9999.
4. PACKAGING SPECIFICATION: TRAY PACK PER PK-74337-001.
5. APPLICABLE STANDARDS: EIA-700A0AF AND SFF-8441.
6. DATE CODE: YR/WK PER EIA-476-A.
7. PRODUCT COMPLIES WITH COSMETIC SPECIFICATION PS-45499-002. SEE FIGURE AT LEFT FOR SURFACE CLASSIFICATIONS.
8. TORQUE TO INSTALL SCREWLOCKS INTO THREADED INSERTS: 0.34 Nm MAXIMUM.

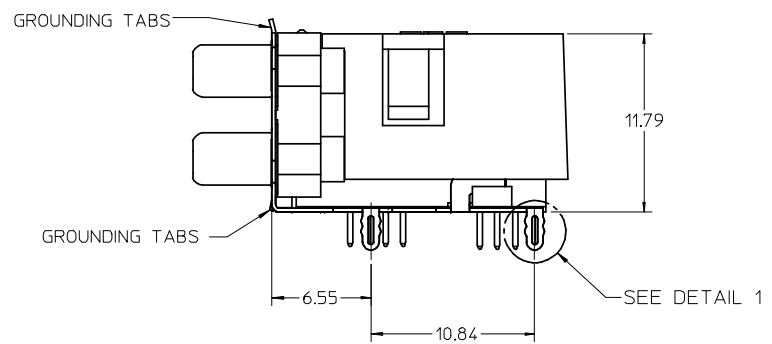
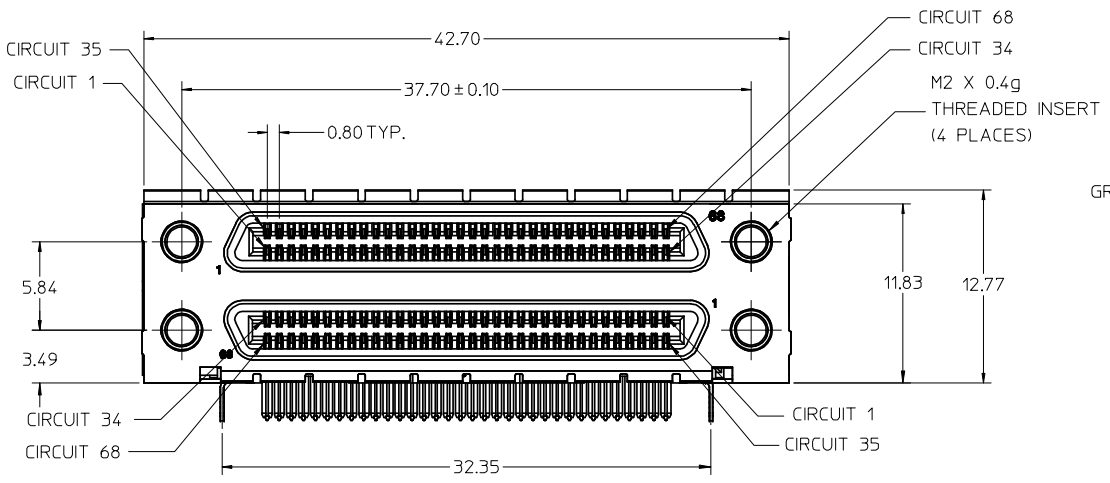

PRESS FIT FORKLOCK SHOWN (VERSION 4)

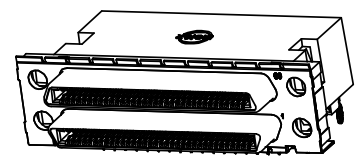

WITH COVER OPTION

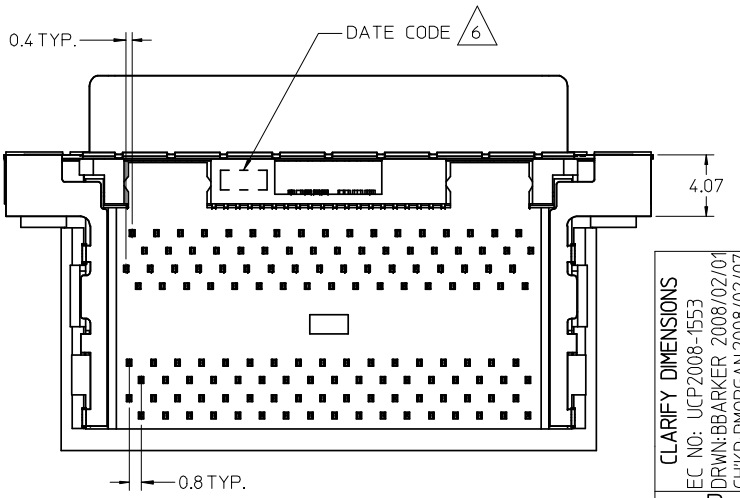

<b>CLARIFY DIMENSIONS</b> EC NO: UCP2008-1553 DRWN:BBARKER 2008/02/01 CHKD:DMORGAN 2008/02/07 APPR:SMILLER 2008/02/08	QUALITY SYMBOLS ▽ = 0 ▽C = 0	GENERAL TOLERANCES (UNLESS SPECIFIED) <table border="1"> <thead> <tr> <th></th> <th>mm</th> <th>INCH</th> </tr> </thead> <tbody> <tr> <td>4 PLACES</td> <td>± ---</td> <td>± ---</td> </tr> <tr> <td>3 PLACES</td> <td>± ---</td> <td>± ---</td> </tr> <tr> <td>2 PLACES</td> <td>± 0.13</td> <td>± ---</td> </tr> <tr> <td>1 PLACE</td> <td>± 0.25</td> <td>± ---</td> </tr> </tbody> </table> ANGULAR ± 1 °		mm	INCH	4 PLACES	± ---	± ---	3 PLACES	± ---	± ---	2 PLACES	± 0.13	± ---	1 PLACE	± 0.25	± ---	SCALE 3:1 DESIGN UNITS METRIC DIMENSION STYLE MM ONLY	THIRD ANGLE PROJECTION REVISE ON CAD ONLY
		mm	INCH																
	4 PLACES	± ---	± ---																
	3 PLACES	± ---	± ---																
2 PLACES	± 0.13	± ---																	
1 PLACE	± 0.25	± ---																	
		DRAFT WHERE APPLICABLE MUST REMAIN WITHIN DIMENSIONS	DRAWN BY SSAMPSON DATE 05.08.2001 CHECKED BY MBANAKIS DATE 05.08.2001 APPROVED BY MBANAKIS DATE 05.08.2001	TITLE VHDCI STACKED ASSEMBLY															
			MATERIAL NO. SEE TABLE DOCUMENT NO. SD-74337-014 SHEET NO. 1 OF 4	MOLEX INCORPORATED															
			THIS DRAWING CONTAINS INFORMATION THAT IS PROPRIETARY TO MOLEX INCORPORATED AND SHOULD NOT BE USED WITHOUT WRITTEN PERMISSION																

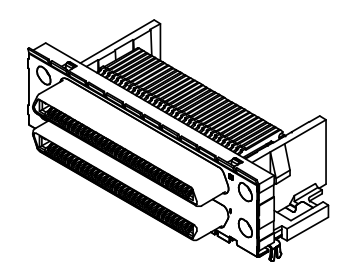
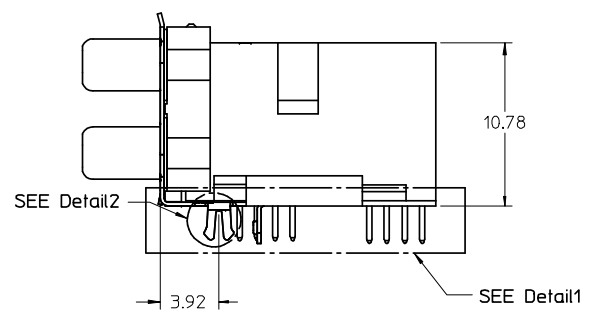
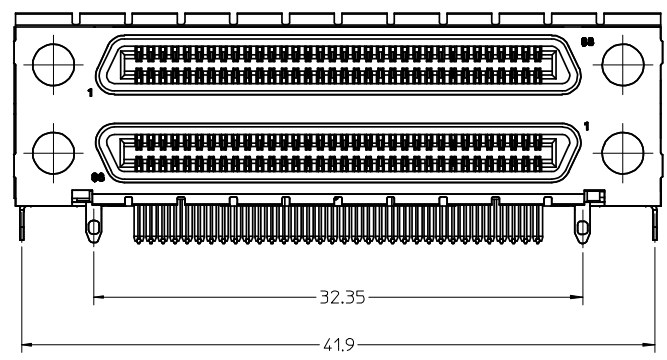
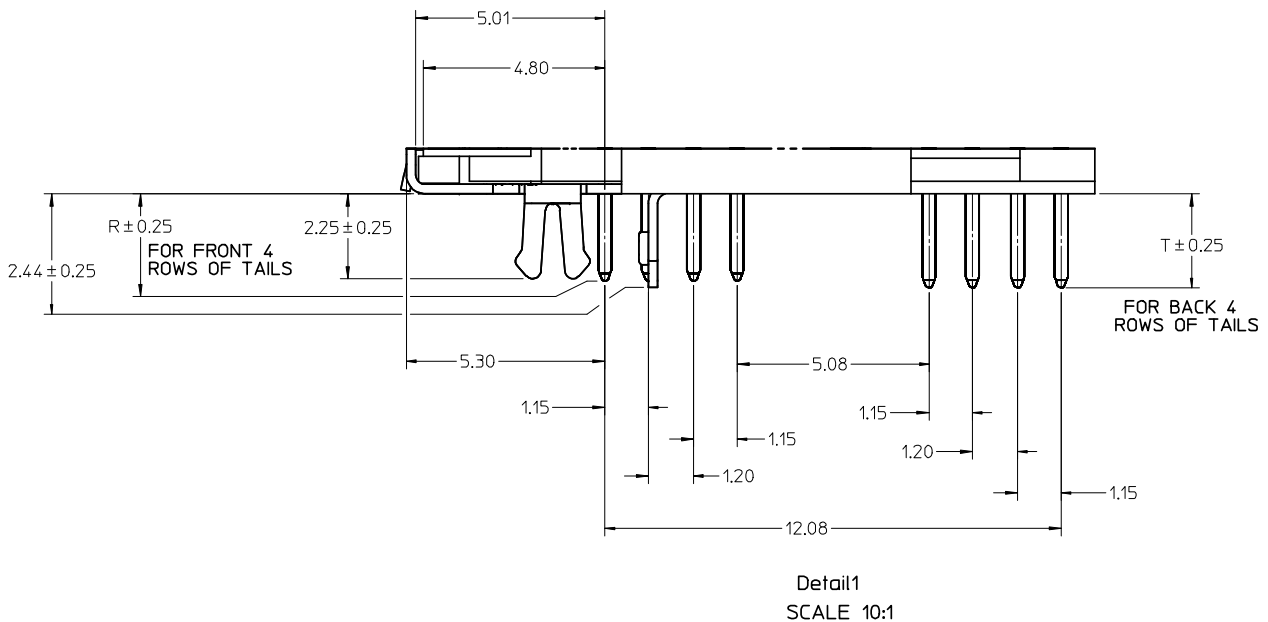
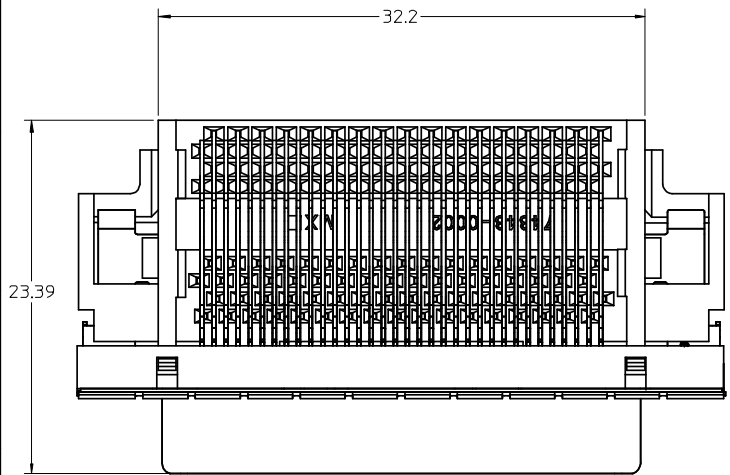

CLARIFY DIMENSIONS EC NO: UCP2008-1553 DRWN:BBARKER 2008/02/01 CHKD:DMORGAN 2008/02/07 APPR:SMILLER 2008/02/08		QUALITY SYMBOLS	GENERAL TOLERANCES (UNLESS SPECIFIED)		SCALE 4:1	DESIGN UNITS METRIC	THIRD ANGLE PROJECTION	REVISE ON CAD ONLY
		▽ = 0 ∇ = 0	mm	INCH	DIMENSION STYLE MM ONLY	TITLE VHCI STACKED ASSEMBLY		
REV	4 PLACES	± ---	± ---	DRAWN BY SSAMPSON	DATE 05.08.2001	MATERIAL NO. SEE TABLE		
	3 PLACES	± ---	± ---	CHECKED BY MBANAKIS	DATE 05.08.2001			
	2 PLACES	± 0.13	± ---	APPROVED BY MBANAKIS		DATE 05.08.2001	SHEET NO. 2 OF 4	
	1 PLACE	± 0.25	± ---	DRAFT WHERE APPLICABLE MUST REMAIN WITHIN DIMENSIONS		THIS DRAWING CONTAINS INFORMATION THAT IS PROPRIETARY TO MOLEX INCORPORATED AND SHOULD NOT BE USED WITHOUT WRITTEN PERMISSION		

### VERSION 1 PART NUMBERS

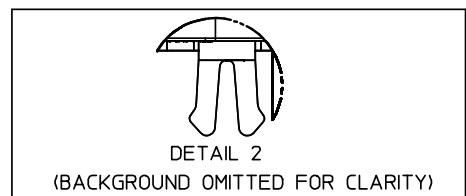

DETAIL 2  
(BACKGROUND OMITTED FOR CLARITY)

BOARD RETENTION: SNAP FIT

PCB THICKNESS	COVER	R DIM.	T DIM.	INCLUDES LOOSE PACKED SCREWLOCKS 71433-0002 SEE DRAWING SD-71433-005	GROUNDING TABS	PART NUMBER
1.60±0.16	YES	2.30	2.48	NO	YES	74337-0011
1.60±0.16	YES	2.08		NO	YES	74337-0012
1.60±0.16	NO	2.30	2.48	NO	YES	74337-0015
1.60±0.16	NO	2.08		NO	YES	74337-0016
1.60±0.16	YES	2.30	2.48	YES	YES	74337-0037
1.60±0.16	YES	2.08		YES	YES	74337-0038
1.60±0.16	NO	2.30	2.48	YES	YES	74337-0039
1.60±0.16	NO	2.08		YES	YES	74337-0040
2.36±0.16	YES	3.44	3.62	NO	YES	74337-0070
2.36±0.16	NO	3.44	3.62	NO	YES	74337-0071
2.36±0.16	YES	3.44	3.62	YES	YES	74337-0072
2.36±0.16	NO	3.44	3.62	YES	YES	74337-0073
1.60±0.16	YES	2.08		INSTALLED ON PART	YES	74337-1038

### VERSION 4 PART NUMBERS

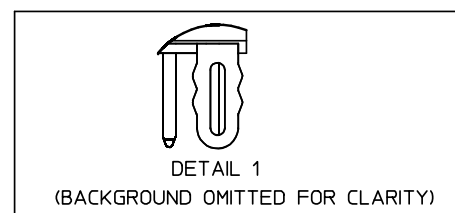

DETAIL 1  
(BACKGROUND OMITTED FOR CLARITY)

BOARD RETENTION: PRESS FIT

PCB THICKNESS	COVER	R DIM.	T DIM.	INCLUDES LOOSE PACKED SCREWLOCKS 71433-0002 SEE DRAWING SD-71433-005	GROUNDING TABS	PART NUMBER
1.60±0.16	YES	2.30	2.48	NO	YES	74337-0050
1.60±0.16	YES	2.08		NO	NO	74337-0051
1.60±0.16	NO	2.30	2.48	NO	YES	74337-0060
1.60±0.16	NO	2.08		NO	YES	74337-0061
1.60±0.16	YES	2.08		NO	YES	74337-0066
1.60±0.16	YES	2.30	2.48	YES	YES	74337-0053
1.60±0.16	YES	2.08		YES	YES	74337-0054
1.60±0.16	NO	2.30	2.48	YES	YES	74337-0063
1.60±0.16	NO	2.08		YES	YES	74337-0064
2.36±0.16	YES	3.44	3.62	NO	YES	74337-0052
2.36±0.16	NO	3.44	3.62	NO	YES	74337-0062
2.36±0.16	YES	3.44	3.62	YES	YES	74337-0055
2.36±0.16	NO	3.44	3.62	YES	YES	74337-0065
1.60±0.16	YES	2.08		INSTALLED ON PART	YES	74337-1054

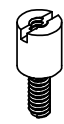

OPTIONAL SCREWLOCK  
71433-0002

CLARIFY DIMENSIONS EC NO: UCP2008-1553 DRWN:BBARKER 2008/02/01 CHKD:DMORGAN 2008/02/07 APPR: SMILLER 2008/02/08	QUALITY SYMBOLS ▽ = 0 ▽ = 0	GENERAL TOLERANCES (UNLESS SPECIFIED) mm INCH 4 PLACES ± --- ± --- 3 PLACES ± --- ± --- 2 PLACES ± 0.13 ± --- 1 PLACE ± 0.25 ± --- ANGULAR ± 1°	SCALE 3:1 DESIGN UNITS METRIC DIMENSION STYLE MM ONLY	THIRD ANGLE PROJECTION REVISE ON CAD ONLY	
	DESCRIPTION R	DRAFT WHERE APPLICABLE MUST REMAIN WITHIN DIMENSIONS	DRAWN BY SSAMPSON DATE 05.08.2001 CHECKED BY MBANAKIS DATE 05.08.2001 APPROVED BY MBANAKIS DATE 05.08.2001	TITLE VHDCI STACKED ASSEMBLY	MATERIAL NO. SEE TABLE DOCUMENT NO. SD-74337-014 SHEET NO. 3 OF 4
	THIS DRAWING CONTAINS INFORMATION THAT IS PROPRIETARY TO MOLEX INCORPORATED AND SHOULD NOT BE USED WITHOUT WRITTEN PERMISSION				
	MOLEX INCORPORATED				

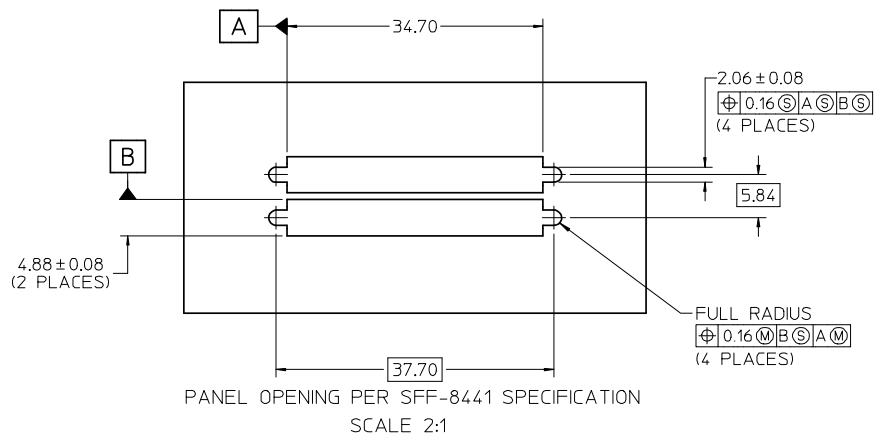
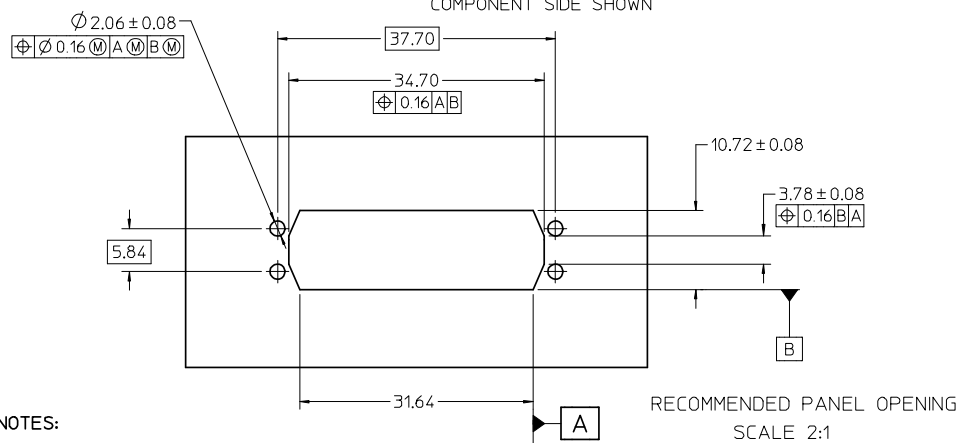
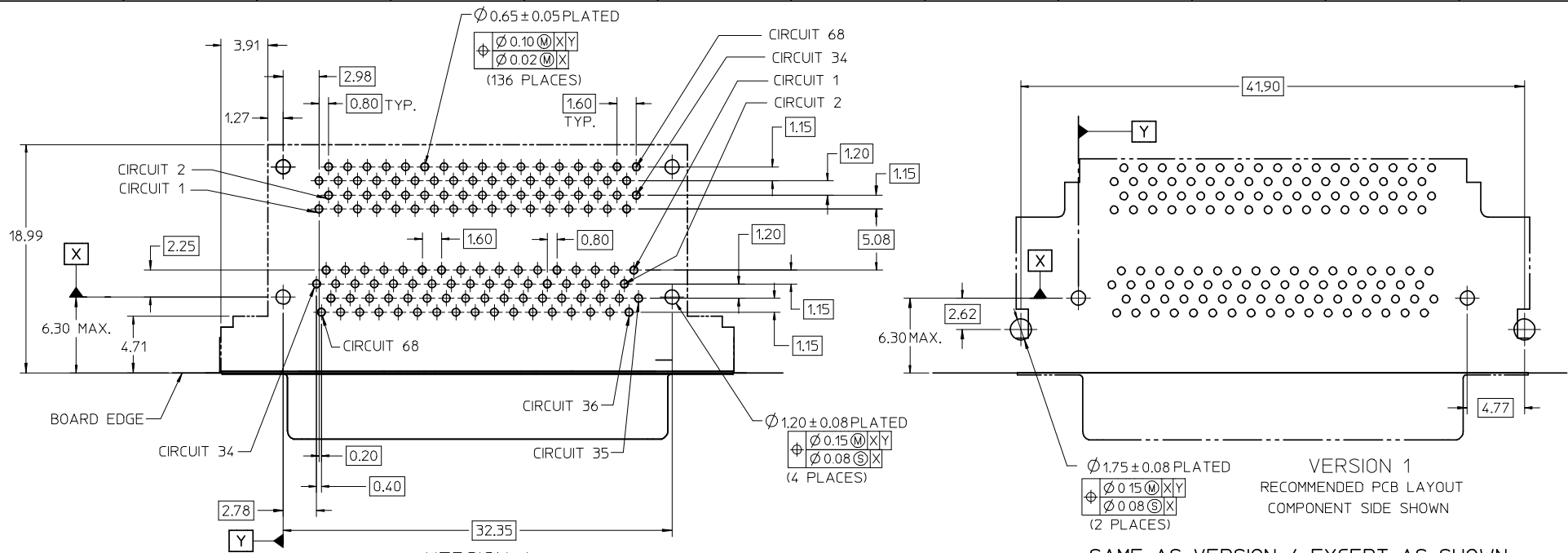

NOTES:

- FOR FULL MATE WITH PLUG, PANEL THICKNESS SHOULD NOT EXCEED 1.0mm.
- FUNCTIONAL MATING WITH MOLEX PLUG CAN STILL BE MAINTAINED WITH PANELS AS THICK AS 2.5mm (BUT PLUG AND RECEPTACLE WILL NOT BE FULLY MATED).
- GUIDELINES FOR CHOOSING A MOLEX SCREWLOCK:

PANEL THICKNESS	RECOMMENDED SCREWLOCK
LESS THAN OR EQUAL TO 1.00 MM	71433-0002
1.01 TO 2.15 MM	71433-0010

CLARIFY DIMENSIONS EC NO: JCP2008-1553 DRWN:BBARKER 2008/02/01 CHKD:DMORGAN 2008/02/07 APPR:SMILLER 2008/02/08	QUALITY SYMBOLS	GENERAL TOLERANCES (UNLESS SPECIFIED)	SCALE 3:1	DESIGN UNITS METRIC	THIRD ANGLE PROJECTION	REVISE ON CAD ONLY															
	▼ - 0 ▽ - 0	<table border="1"> <tr> <th></th> <th>mm</th> <th>INCH</th> </tr> <tr> <td>4 PLACES</td> <td>± ---</td> <td>± ---</td> </tr> <tr> <td>3 PLACES</td> <td>± ---</td> <td>± ---</td> </tr> <tr> <td>2 PLACES</td> <td>± 0.13</td> <td>± ---</td> </tr> <tr> <td>1 PLACE</td> <td>± 0.25</td> <td>± ---</td> </tr> </table>		mm	INCH	4 PLACES	± ---	± ---	3 PLACES	± ---	± ---	2 PLACES	± 0.13	± ---	1 PLACE	± 0.25	± ---	DIMENSION STYLE MM ONLY	TITLE	VHDCI STACKED ASSEMBLY	
			mm	INCH																	
	4 PLACES	± ---	± ---																		
3 PLACES	± ---	± ---																			
2 PLACES	± 0.13	± ---																			
1 PLACE	± 0.25	± ---																			
DRAFT WHERE APPLICABLE MUST REMAIN WITHIN DIMENSIONS		DRAWN BY DATE SSAMPSON 05.08.2001	CHECKED BY DATE MBANAKIS 05.08.2001	MOLEX INCORPORATED																	
		APPROVED BY DATE MBANAKIS 05.08.2001	MATERIAL NO. SEE TABLE	DOCUMENT NO. SD-74337-014	SHEET NO. 4 OF 4																
THIS DRAWING CONTAINS INFORMATION THAT IS PROPRIETARY TO MOLEX INCORPORATED AND SHOULD NOT BE USED WITHOUT WRITTEN PERMISSION																					