

SINGLE-CHIP VOICE RECORD/PLAYBACK DEVICES

1. GENERAL DESCRIPTION

GPCR06B, a new recordable and playback voice device without CPU designed by Generalplus, is a highly integrated circuit that contains all of the necessary functions for providing high quality voice recording and playback. Easy-to-use, low power consumption and compact size are the tremendous features of GPCR06B. Total of 160K bits SRAM are capable of storing approximately 7 seconds of audio or speech voice (@ 6.0KHz sampling rate). The development team of GPCR06B designs especially for compact message recorder, recordable toys and other similar products. It is willing to provide the best cost/performance ratio for users.

2. FEATURES

- Nature, high-quality playback suitable for voice, music, and tones
- Single-chip voice record and playback device
- Microphone preamplifier
- Built in 160K bits SRAM
- Selective sampling rate (Bonding option select 6KHz or 4.3KHz)
- Prompt beep sound (Bonding option select beep sound or not)
- Operating power supply (2.4V - 5.5V)

3. SUITABLE APPLICATION

- Memo Message Recorder
- Hand-Carried Message Recorder
- Recordable Toys

4. BLOCK DIAGRAM

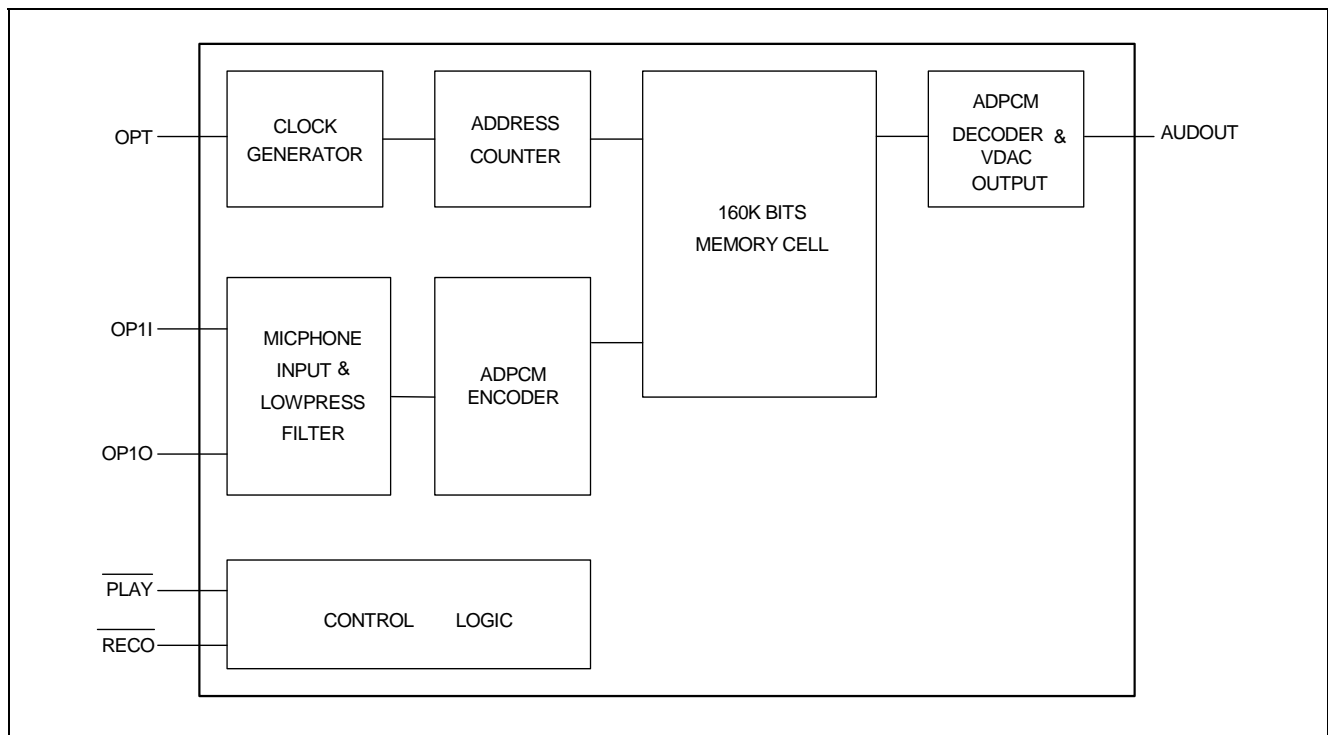

5. SIGNAL DESCRIPTIONS

Mnemonic	PIN No.	Type	Description
PLAY_BUSY	1	O	The state of this pin will be high while playing.
RECLEL	2	O	The state of this pin will be high while recording message.
RECO	3	I	RECO , the record-request pin of GPCR06A, normally is connected to a key. GPCR06A is able to record voice as long as the key is being pressed (low active).
PLAY	4	I	PLAY , the play-request pin of GPCR06A, normally is connected to a key. When the key is pressed (falling edge triggering), GPCR06A is able to perform play function.
OPT*	5	I	Rosc option, the pin can be used to remold the R to offer various based frequency, i.e., the sampling rate, 4.3KHz or 6.0KHz, is optional.
AVDD, VDD	10, 6	Power	Analog and Digital power buses.
BPOPT	7	I	Beep option, the pin can be used to offer "beep" voice when press RECO key, i.e., BPOPT VDD bonding together will have no "beep" function; BPOPT floating will have "beep" function
AVSS, VSS	9, 14	Ground	Analog and Digital ground buses.
TEST	8	I	GPCR06A is able to perform the testing mod when the pin is low.
OP1I	11	I	OP input of MIC preamplifier.
OP1O	12	O	OP output of MIC preamplifier.
AUDOUT	13	O	AUDIO voltage output.

Note: *OPT is the selection pin for various based frequency. The shape looks like in the right figure. The reason of OPT bonded near by VDD is that when high frequency is selected, it will make connection between VDD and OPT easily.

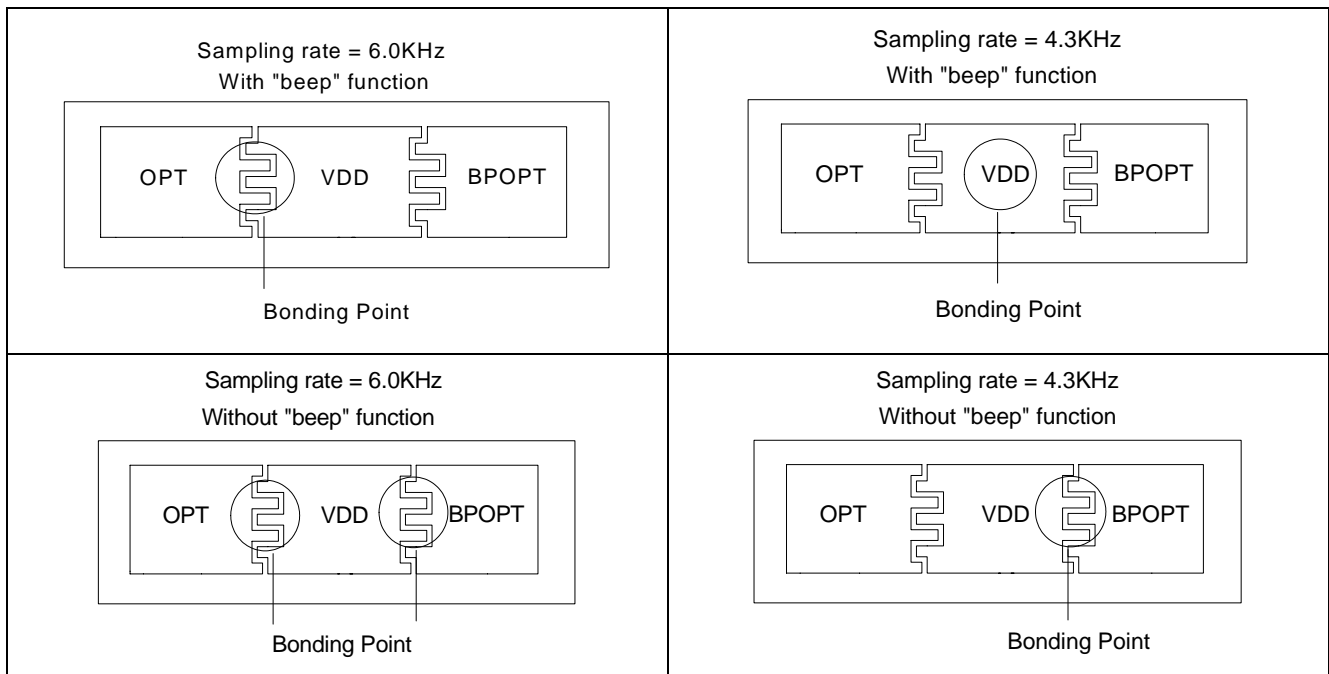

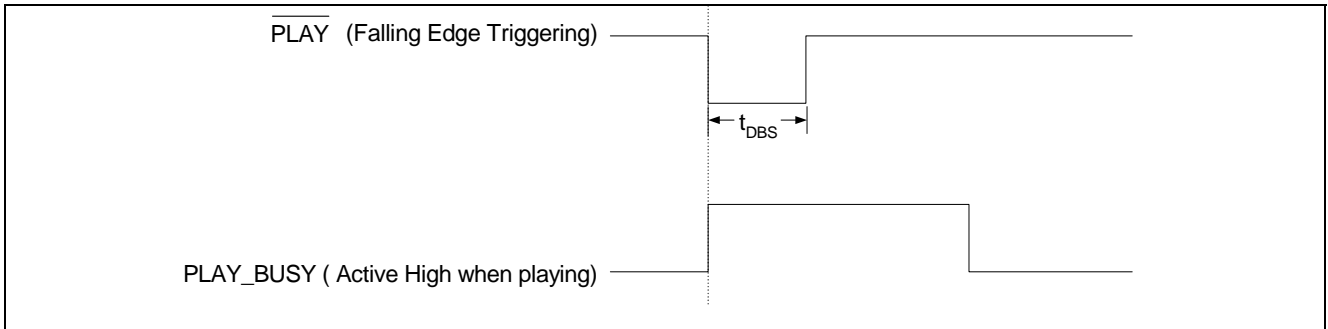

Note: The de-bounce time (t_{DBS}) of $\overline{\text{PLAY}}$ is $412 * \frac{1}{F_s}$, where F_s is the sampling rate.

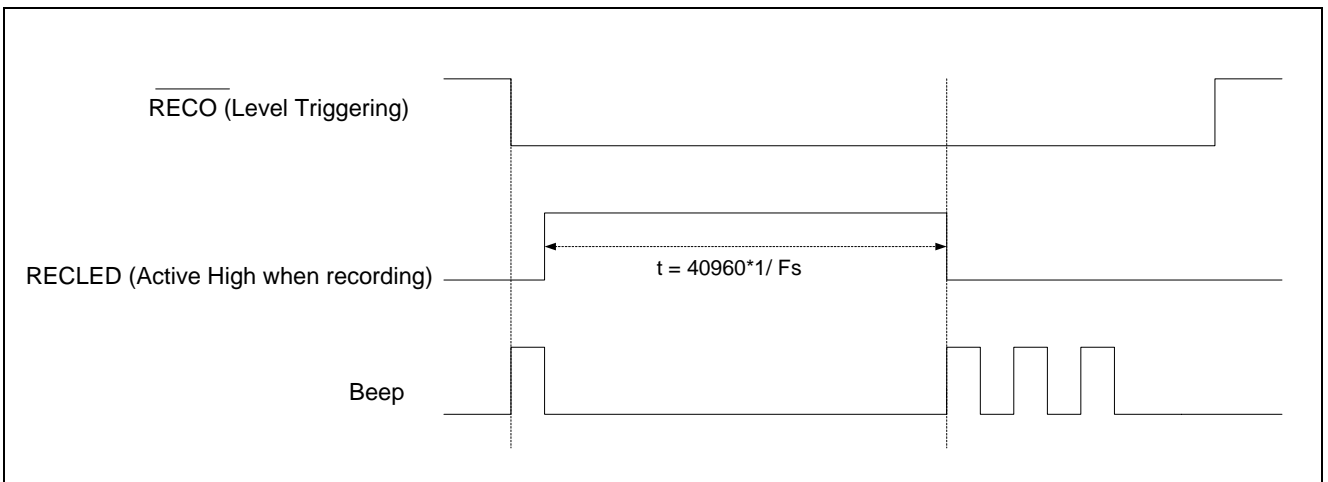

6. ELECTRICAL SPECIFICATIONS

6.1. Absolute Maximum Ratings

Characteristics	Ratings
Operating Temperature	0°C to 70°C
Storage temperature range	-65°C to 150°C
Voltage applied to any pin	(VSS-0.3V) to (VDD+0.3V)
Lead temperature	Soldering - 10 seconds 300°C
VDD - VSS	-0.3V to 7.0V

Note: Stresses beyond those given in the Absolute Maximum Ratings table may cause operational errors or damage to the device. For normal operational conditions see AC/DC Electrical Characteristics.

6.2. DC Characteristics

Characteristics	Symbol	Limit			Unit	Condition
		Min.	Typ.	Max.		
Input low voltage	V_{IL}	VSS	-	0.2xVDD	V	-
Input high voltage	V_{IH}	0.7xVDD	-	VDD	V	-
Output low voltage	V_{OL}	-	-	0.4	V	VDD = 4.5V, I_{OL} = 4.0mA
Output high voltage	V_{OH}	4.0	-	-	V	VDD = 4.5V, I_{OH} = 1.0mA
VDD current	I_{CC}	-	-	10	mA	No load, VDD = 5.5V
Standby current	I_{SB}	-	-	5.0	μ A	VDD = 5.5V

7. APPLICATION CIRCUITS

7.1. Application Circuit - (1)

The system is capable of recording as long as the switch of RECO is being pressed (level triggering). The recorded message or audio can be playbacked when the switch of PLAY

is pressed (falling edge triggering). When system is in recording, the LED from RECLED will be lighted on till the end of recording.

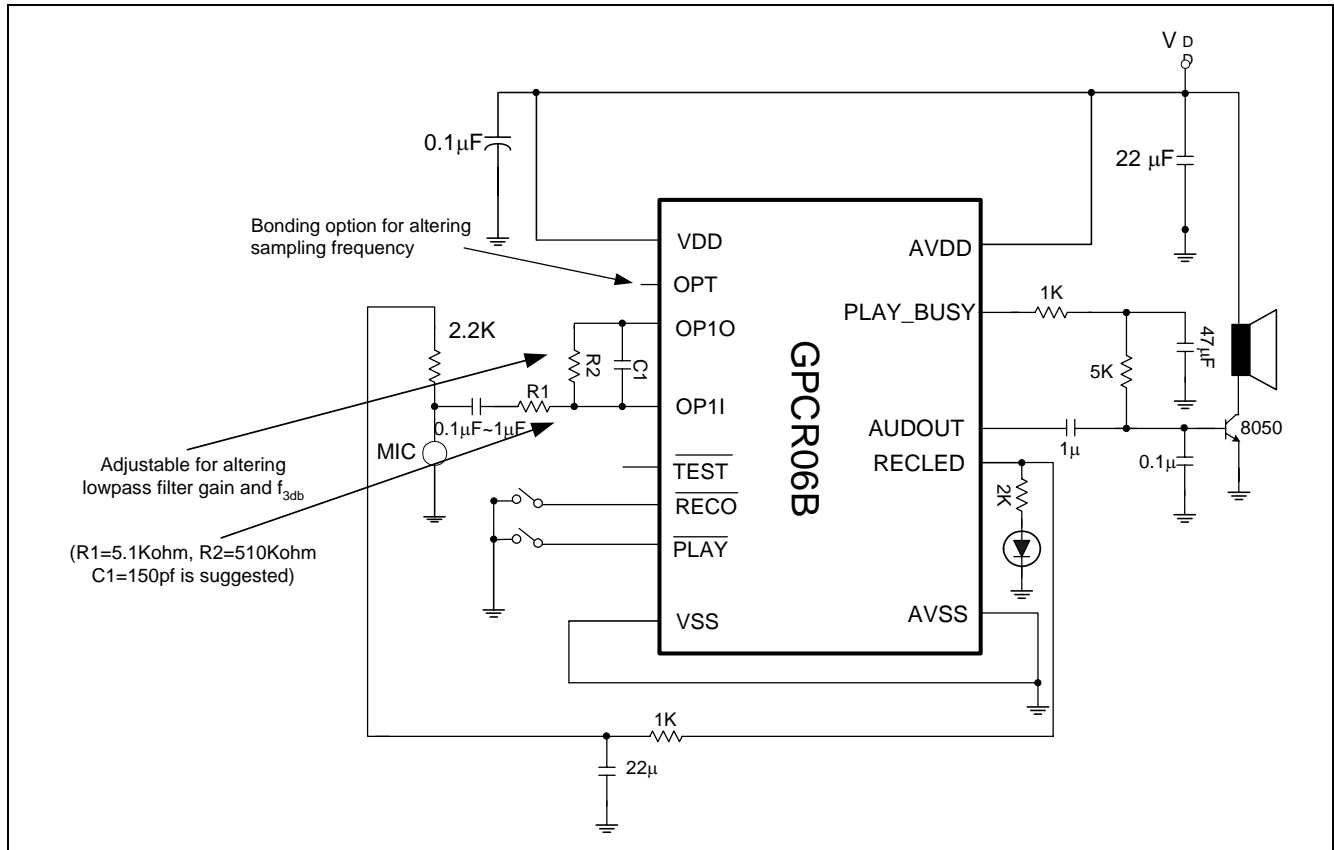

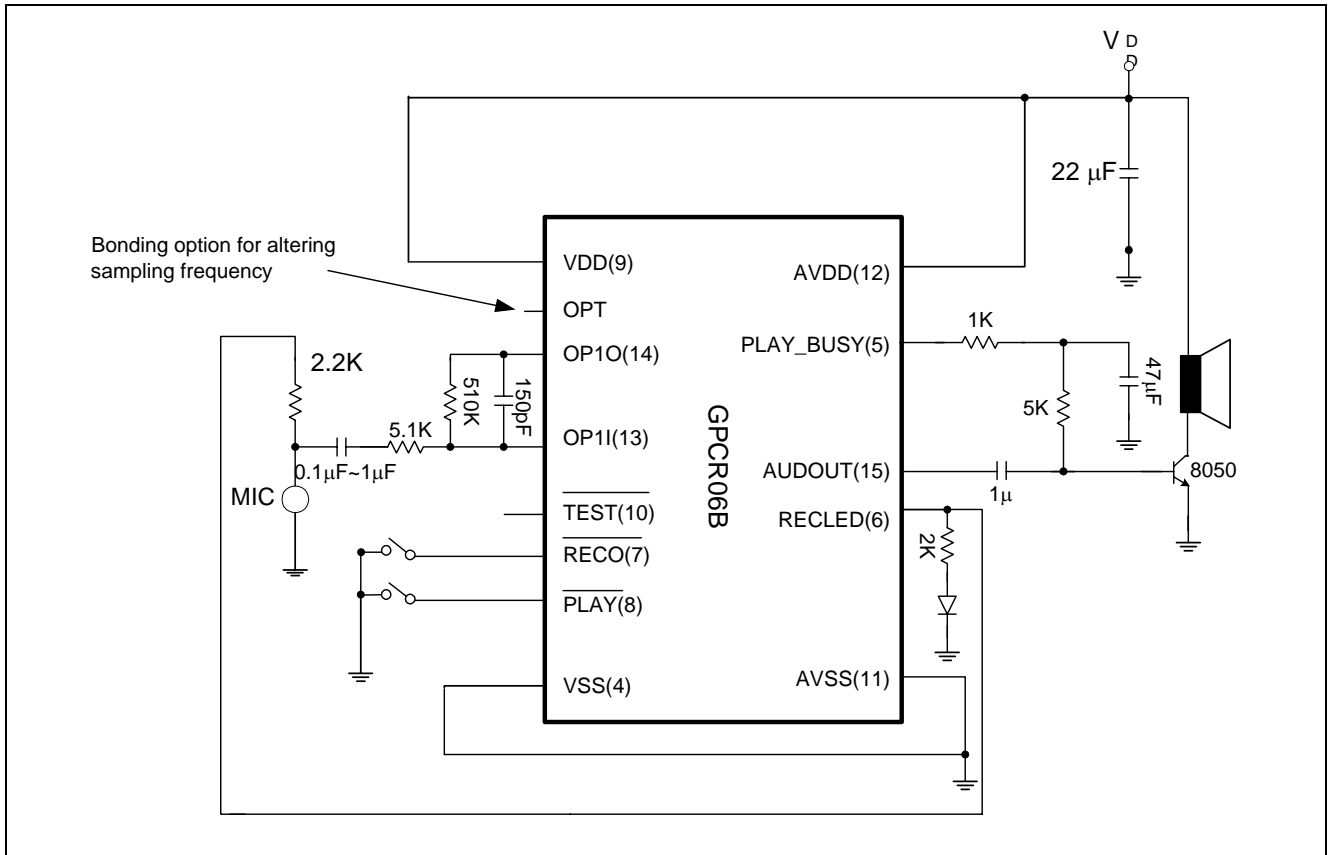

7.2. Application Circuit - (2)

This circuit offers the same functionalities as the previous circuit. However, the following circuit uses SPY0012B or SPY0030A in

place of transistor to drive speaker.

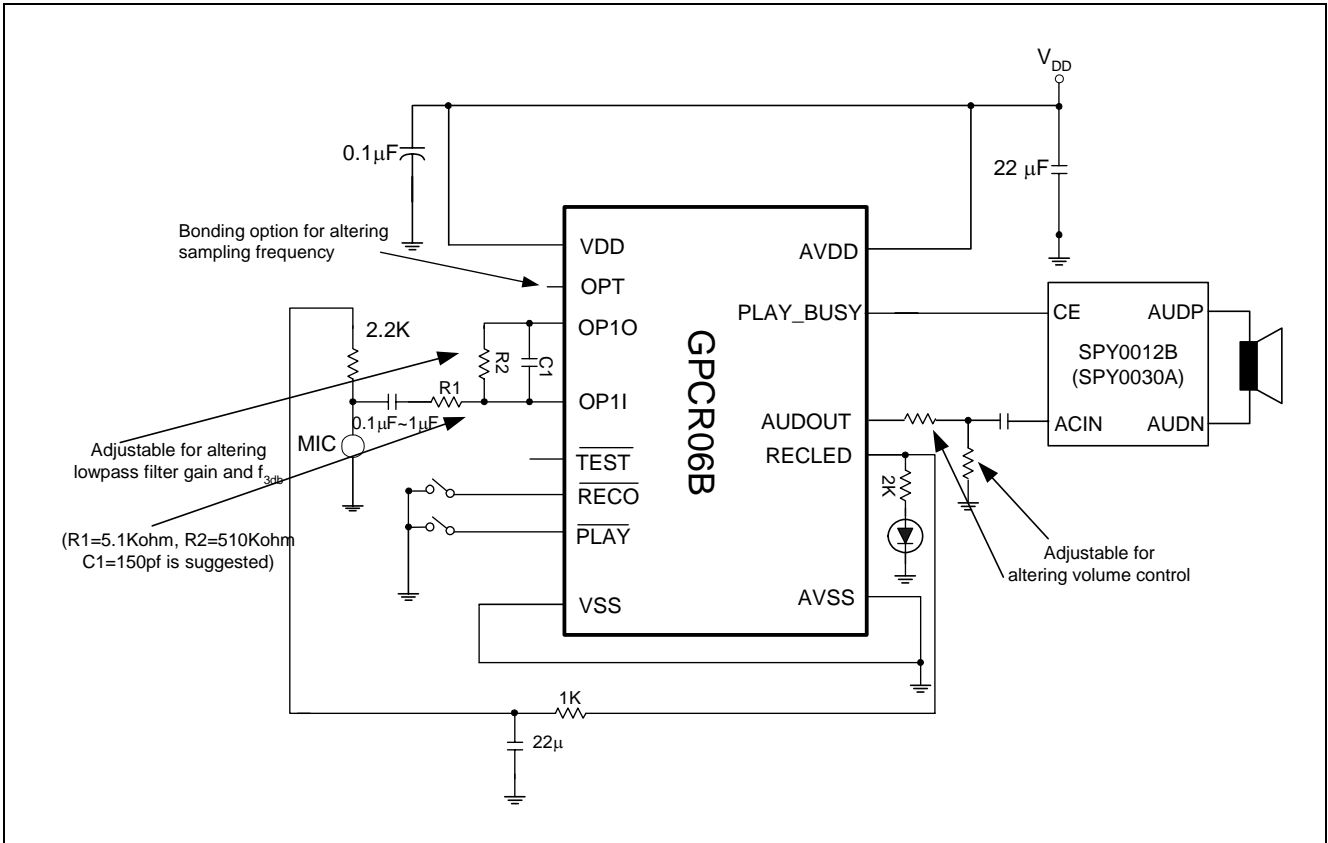

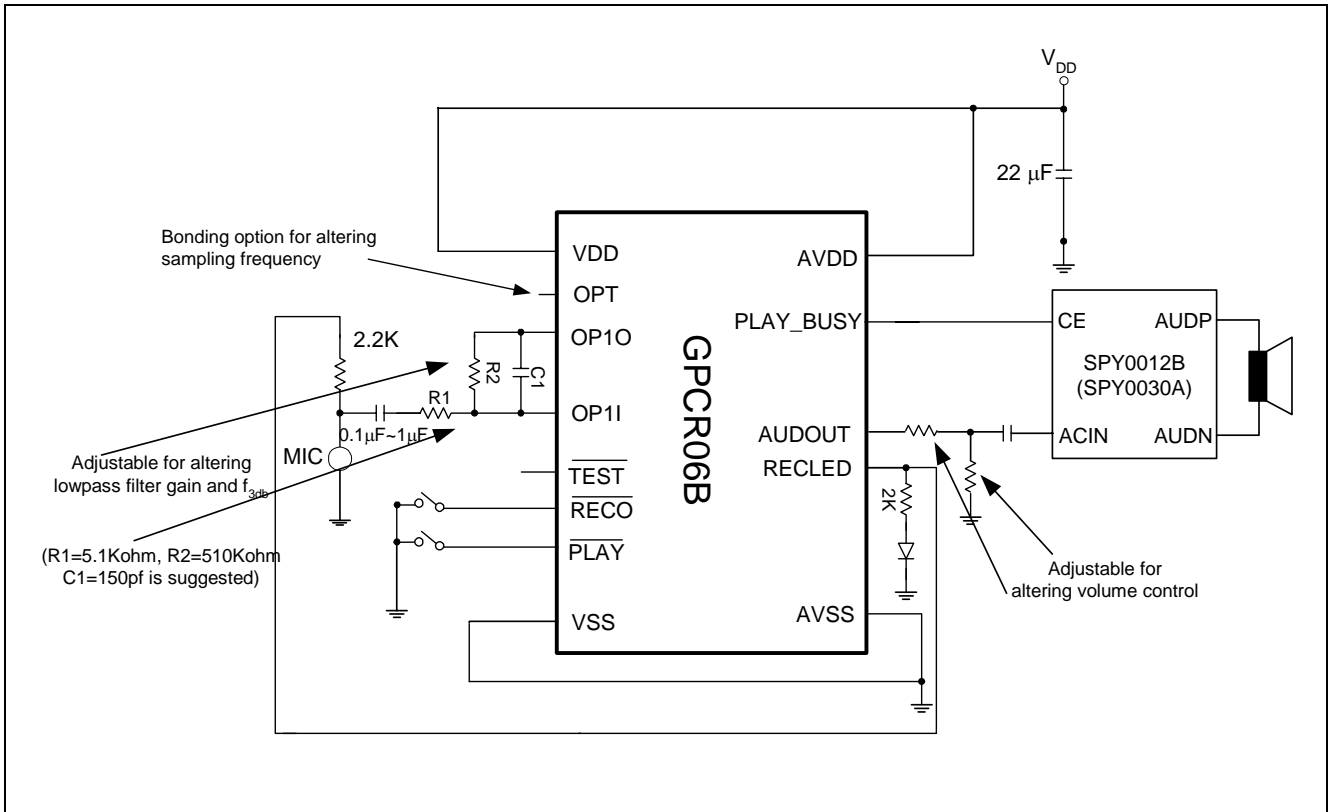

8. PACKAGE/PAD LOCATIONS

8.1. PAD Assignment

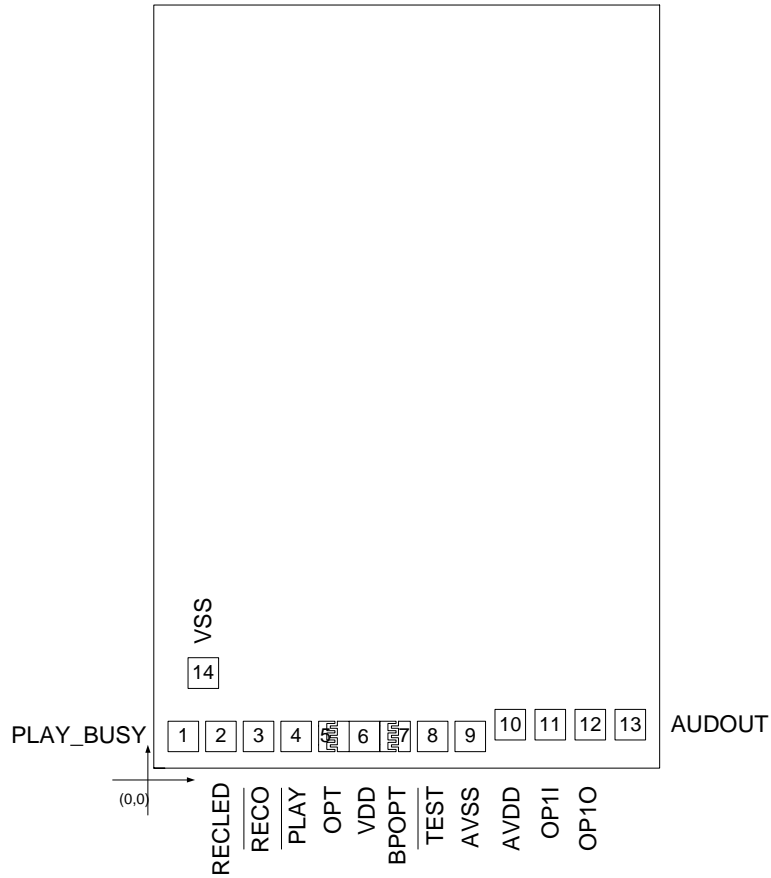

This IC substrate should be connected to VDD

Note1: Chip size has included scribe line.

Note1: To ensure that the IC functions properly, please bond all of VDD and VSS pins.

Note2: The 0.1μF capacitor between VDD and VSS should be placed to IC as close as possible.

8.2. Ordering Information

Product Number	Package Type
GPCR06B-NnnV-C	Chip form

Note1: Code number is assigned for customer.

Note2: Code number (N = A - Z or 0 - 9, nn = 00 - 99); version (V = A - Z).

8.3. PAD Locations

PAD No.	PAD Name	X	Y
1	PLAY_BUSY	106	136
2	RECLED	241	136
3	RECO	388	136
4	PLAY	523	136
5	OPT	668	136
6	VDD	766	136
7	BPOPT	864	136
8	TEST	983	136
9	AVSS	1112	136
10	AVDD	1232	159
11	OP1I	1352	159
12	OP1O	1479	159
13	AUDOUT	1599	159
14	VSS	155	383

9. DISCLAIMER

The information appearing in this publication is believed to be accurate.

Integrated circuits sold by Generalplus Technology are covered by the warranty and patent indemnification provisions stipulated in the terms of sale only. GENERALPLUS makes no warranty, express, statutory implied or by description regarding the information in this publication or regarding the freedom of the described chip(s) from patent infringement. FURTHERMORE, GENERALPLUS MAKES NO WARRANTY OF MERCHANTABILITY OR FITNESS FOR ANY PURPOSE. GENERALPLUS reserves the right to halt production or alter the specifications and prices at any time without notice. Accordingly, the reader is cautioned to verify that the data sheets and other information in this publication are current before placing orders. Products described herein are intended for use in normal commercial applications. Applications involving unusual environmental or reliability requirements, e.g. military equipment or medical life support equipment, are specifically not recommended without additional processing by GENERALPLUS for such applications. Please note that application circuits illustrated in this document are for reference purposes only.

10. REVISION HISTORY

Date	Revision #	Description	Page
MAR. 03, 2005	1.1	Remove Chip Size	9
JUN. 07, 2004	1.0	Original Note: The GPCR06B data sheet v1.0 is a continued version of SPCR06B data sheet v0.1.	12