

S71WS512NE0BFWZZ

**Stacked Multi-Chip Product (MCP) Flash Memory
and pSRAM CMOS 1.8 Volt,
Simultaneous Operation, Burst Mode Flash Memory
and Pseudo-Static RAM**



**ADVANCE
INFORMATION**

DISTINCTIVE CHARACTERISTICS

MCP Features

- **Operating Voltage Range of 1.65 to 1.95 V**
- **High Performance**
 - Speed: 54MHz
- **Packages**
 - 96-ball FBGA—9 x 12 mm
- **Operating Temperatures**
 - Wireless: -25°C to +85°C

GENERAL DESCRIPTION

The S71WS512 Series is a product line of stacked Multi-Chip Products (MCP) and consists of

- **One or more S29WS256N (Simultaneous Operation, Burst Mode) Flash Die**
- **pSRAM options**
 - 128Mb pSRAM

The products covered by this document are listed below. For details about their specifications, please refer to the individual constituent data sheets for further details.

MCP	Number of S29WSxxxN	Total Flash Density	pSRAM Density
S71WS512NE0	2	512Mb	256Mb

Notes:

1. This MCP is only guaranteed to operate @ 1.65 - 1.95 V regardless of component operating ranges.

Product Selector Guide

Device-Model #	SRAM/pSRAM Density	SRAM/pSRAM Type	Supplier	Flash Access Time (MHz)	RAM Access Time (MHz)	Packages
S71WS512NE0BFWZZ	256Mb	pSRAM - x16	COSMORAM 1	54	54	TBD

TABLE OF CONTENTS

S71WS512NE0BFWZZ

Distinctive Characteristics 1
General Description 1
Product Selector Guide 2
Block Diagrams 6
 MCP Block Diagram of S71WS512NE0BFWZZ 6
Connection Diagrams 7
 Connection Diagram of S71WS512NE0BFWZZ 7
 Special Package Handling Instructions 8
 Pin Description 8
 Logic Symbol 9
 Device Bus Operation 10
 Table 1. Device Bus Operations 10
 Pin Capacitance 12
Physical Dimensions TBD 13
 XXX 13

**S29WSxxxN MirrorBit™ Flash Family
 For Multi-chip Products (MCP)**

Distinctive Characteristics 14
General Description 16
Product Selector Guide 19
 Block Diagram 19
Block Diagram of Simultaneous Operation Circuit
 20
Input/Output Descriptions 21
Logic Symbol 22
Device Bus Operations 23
 Table 2. Device Bus Operations 23
 Requirements for Asynchronous Read Operation (Non-Burst) 23
 Requirements for Synchronous (Burst) Read Operation 24
 Table 3. Address Dependent Additional Latency 24
 Continuous Burst 24
 8-, 16-, and 32-Word Linear Burst with Wrap Around 25
 Table 4. Burst Address Groups 25
 8-, 16-, and 32-Word Linear Burst without Wrap Around 25
 Configuration Register 25
 Handshaking 25
 Simultaneous Read/Write Operations with Zero Latency 26
 Writing Commands/Command Sequences 26
 Unlock Bypass Mode 26
 Accelerated Program/Erase Operations 26
 Write Buffer Programming Operation 27
 Autoselect Mode 28
 Advanced Sector Protection and Unprotection 29
 Persistent Mode Lock Bit 29
 Password Mode Lock Bit 30
 Sector Protection 30
 Persistent Sector Protection 30
 Persistent Protection Bit (PPB) 31
 Persistent Protection Bit Lock (PPB Lock Bit) in Persistent Sector
 Protection Mode 31
 Dynamic Protection Bit (DYB) 31
 Table 5. Sector Protection Schemes 32
 Password Sector Protection 33
 64-bit Password 33

Persistent Protection Bit Lock (PPB Lock Bit) in Password Sector
 Protection Mode 33
 Lock Register 34
 Table 6. Lock Register 34
 Hardware Data Protection Mode 34
 Write Protect (WP#) 34
 Low V_{CC} Write Inhibit 34
 Write Pulse “Glitch” Protection 35
 Logical Inhibit 35
 Power-Up Write Inhibit 35
 Standby Mode 35
 Automatic Sleep Mode 35
 RESET#: Hardware Reset Input 35
 Output Disable Mode 36
 SecSi™ (Secured Silicon) Sector Flash Memory Region 36
 Factory Locked: Factor SecSi Sector Programmed and Protected At
 the Factory 36
 Table 7. SecSi™ Sector Addresses 37
 Customer SecSi Sector 37
 SecSi Sector Protection Bit 37
Common Flash Memory Interface (CFI) 37
 Table 8. CFI Query Identification String 38
 Table 9. System Interface String 38
 Table 10. Device Geometry Definition 39
 Table 11. Primary Vendor-Specific Extended Query 39
 Table 12. Sector Address / Memory Address Map for the WS256N
 41
Command Definitions 49
 Reading Array Data 49
 Set Configuration Register Command Sequence 49
 Read Configuration Register Command Sequence 50
 Figure 1. Synchronous/Asynchronous State Diagram 50
 Read Mode Setting 50
 Programmable Wait State Configuration 50
 Table 13. Programmable Wait State Settings 51
 Programmable Wait State 51
 Boundary Crossing Latency 51
 Set Internal Clock Frequency 51
 Table 14. Wait States for Handshaking 51
 Handshaking 51
 Burst Sequence 52
 Burst Length Configuration 52
 Table 15. Burst Length Configuration 52
 Burst Wrap Around 52
 Burst Active Clock Edge Configuration 52
 RDY Configuration 52
 RDY Polarity 52
 Configuration Register 53
 Table 16. Configuration Register 53
 Reset Command 53
 Autoselect Command Sequence 54
 Table 17. Autoselect Addresses 54
 Enter SecSi™ Sector/Exit SecSi Sector Command Sequence 55
 Word Program Command Sequence 55
 Write Buffer Programming Command Sequence 56
 Table 18. Write Buffer Command Sequence 56
 Figure 2. Write Buffer Programming Operation 57
 Unlock Bypass Command Sequence 57
 Figure 3. Program Operation 58

Chip Erase Command Sequence 58
Sector Erase Command Sequence 59
Erase Suspend/Erase Resume Commands 60
 Figure 4. Erase Operation 61
Program Suspend/Program Resume Commands 61
Lock Register Command Set Definitions 62
Password Protection Command Set Definitions 62
Non-Volatile Sector Protection Command Set Definitions 63
Global Volatile Sector Protection Freeze Command Set 64
Volatile Sector Protection Command Set 65
SecSi Sector Entry Command 65
Command Definition Summary 66
Write Operation Status 69
DQ7: Data# Polling 69
 Figure 5. Data# Polling Algorithm 70
RDY: Ready 70
DQ6: Toggle Bit I 70
 Figure 6. Toggle Bit Algorithm 71
DQ2: Toggle Bit II 72
 Table 19. DQ6 and DQ2 Indications 72
Reading Toggle Bits DQ6/DQ2 72
DQ5: Exceeded Timing Limits 73
DQ3: Sector Erase Timer 73
DQ1: Write to Buffer Abort 73
 Table 20. Write Operation Status 74
Absolute Maximum Ratings 75
 Figure 7. Maximum Negative Overshoot Waveform 75
 Figure 8. Maximum Positive Overshoot Waveform 75
Operating Ranges 75
DC Characteristics 76
CMOS Compatible 76
Test Conditions 77
 Figure 9. Test Setup 77
 Table 21. Test Specifications 77
Switching Waveforms 77
 Table 22. Key to Switching Waveforms 77
 Figure 10. Input Waveforms and Measurement Levels 77
V_{CC} Power-up 78
 Figure 11. V_{CC} Power-up Diagram 78
Pin Capacitance 78
AC Characteristics—Synchronous 79
CLK Characterization 79
 Figure 12. CLK Characterization 79
Synchronous/Burst Read @ V_{IO} = 1.8 V 80
Timing Diagrams 81
 Figure 13. CLK Synchronous Burst Mode Read (rising active CLK) 81
 Figure 14. Synchronous Burst Mode Read 82
 Figure 15. Eight-word Linear Burst with Wrap Around 82
 Figure 16. Eight-word Linear Burst without Wrap Around 83
 Figure 17. Linear Burst with RDY Set One Cycle Before Data 83
AC Characteristics—Asynchronous 84
Asynchronous Mode Read @ V_{IO}P5 = 1.8 V 84
Timing Diagrams 84
 Figure 18. Asynchronous Mode Read with Latched Addresses 84
 Figure 19. Asynchronous Mode Read 85
Hardware Reset (RESET#) 85
 Figure 20. Reset Timings 85
Erase/Program Operations @ V_{IO} = 1.8 V 86
 Figure 21. Asynchronous Program Operation Timings: WE# Latched Addresses 87

Figure 22. Synchronous Program Operation Timings: CLK Latched Addresses 88
Figure 23. Accelerated Unlock Bypass Programming Timing 88
Figure 24. Data# Polling Timings (During Embedded Algorithm) 89
Figure 25. Toggle Bit Timings (During Embedded Algorithm) 89
Figure 26. Synchronous Data Polling Timings/Toggle Bit Timings 90
Figure 27. DQ2 vs. DQ6 90
Figure 28. Latency with Boundary Crossing when Frequency > 66 MHz 91
Figure 29. Latency with Boundary Crossing into Program/Erase Bank 91
Figure 30. Example of Wait States Insertion 92
Figure 31. Back-to-Back Read/Write Cycle Timings 92
Erase and Programming Performance 93

128Mb pSRAM

FEATURES 94
FUNCTION TRUTH TABLE 95
 Asynchronous Operation (Page Mode) 95
FUNCTION TRUTH TABLE (Continued) 96
 Synchronous Operation (Burst Mode) 96
STATE DIAGRAM 97
FUNCTIONAL DESCRIPTION 98
 Power-up 98
 Configuration Register 98
 CR Set Sequence 98
FUNCTIONAL DESCRIPTION (Continued) .. 99
 Address Key 99
FUNCTIONAL DESCRIPTION (Continued) . 100
 Power Down 100
FUNCTIONAL DESCRIPTION (Continued) .. 101
 Burst Read/Write Operation 101
FUNCTIONAL DESCRIPTION (Continued) . 102
 CLK Input Function 102
 ADV# Input Function 102
 WAIT# Output Function 102
FUNCTIONAL DESCRIPTION (Continued) .. 103
 Latency 103
FUNCTIONAL DESCRIPTION (Continued) . 104
 Address Latch by ADV# 104
 Burst Length 104
 Single Write 104
 Write Control 105
FUNCTIONAL DESCRIPTION (Continued) . 106
 Burst Read Suspend 106
 Burst Write Suspend 106
FUNCTIONAL DESCRIPTION (Continued) .. 107
 Burst Read Termination 107
 Burst Write Termination 107
ABSOLUTE MAXIMUM RATINGS (See WARNING below.) 108
RECOMMENDED OPERATING CONDITIONS (See WARNING below.) 108
 (Referenced to VSS) 108
DC CHARACTERISTICS
..... (Under Recommended Operating Conditions unless otherwise noted) Note *1,*2,*3 109

AC CHARACTERISTICS
(Under Recommended Operating Conditions unless otherwise noted) I10
 ASYNCHRONOUS READ OPERATION (PAGE MODE) I10
AC CHARACTERISTICS (Continued) I11
 ASYNCHRONOUS WRITE OPERATION I11
AC CHARACTERISTICS (Continued) I12
 SYNCHRONOUS OPERATION - CLOCK INPUT (BURST MODE) I12
 SYNCHRONOUS OPERATION - ADDRESS LATCH (BURST MODE) I12
AC CHARACTERISTICS (Continued) I13
 SYNCHRONOUS READ OPERATION (BURST MODE) I13
AC CHARACTERISTICS (Continued) I14
 SYNCHRONOUS WRITE OPERATION (BURST MODE) I14
AC CHARACTERISTICS (Continued) I15
 POWER DOWN PARAMETERS I15
 OTHER TIMING PARAMETERS I15
AC CHARACTERISTICS (Continued) I16
 AC TEST CONDITIONS I16
 AC MEASUREMENT OUTPUT LOAD CIRCUIT I16
TIMING DIAGRAMS I17
 Asynchronous Read Timing #1-1 (Basic Timing) I17
 Asynchronous Read Timing #1-2 (Basic Timing) I17
TIMING DIAGRAMS (Continued) I18
 Asynchronous Read Timing #2 (OE# & Address Access) I18
 Asynchronous Read Timing #3 (LB# / UB# Byte Access) I18
TIMING DIAGRAMS (Continued) I19
 Asynchronous Read Timing #4 (Page Address Access after CE# Control Access) I19
 Asynchronous Read Timing #5 (Random and Page Address Access) I19
TIMING DIAGRAMS (Continued) I20
 Asynchronous Write Timing #1-1 (Basic Timing) I20
 Asynchronous Write Timing #1-2 (Basic Timing) I20
TIMING DIAGRAMS (Continued) I21
 Asynchronous Write Timing #2 (WE# Control) I21
 Asynchronous Write Timing #3-1 (WE# / LB# / UB# Byte Write Control) I21
TIMING DIAGRAMS (Continued) I22
 Asynchronous Write Timing #3-2 (WE# / LB# / UB# Byte Write Control) I22
 Asynchronous Write Timing #3-3 (WE# / LB# / UB# Byte Write Control) I22
TIMING DIAGRAMS (Continued) I23
 Asynchronous Write Timing #3-4 (WE# / LB# / UB# Byte Write Control) I23

TIMING DIAGRAMS (Continued) I24
 Asynchronous Read / Write Timing #1-1 (CE# Control) I24
 Asynchronous Read / Write Timing #1-2 (CE# / WE# / OE# Control) I24
TIMING DIAGRAMS (Continued) I25
 Asynchronous Read / Write Timing #2 (OE#, WE# Control) I25
 Asynchronous Read / Write Timing #3 (OE#, WE#, LB#, UB# Control) I25
TIMING DIAGRAMS (Continued) I26
 Clock Input Timing I26
 Address Latch Timing (Synchronous Mode) I26
TIMING DIAGRAMS (Continued) I27
 Synchronous Read Timing #1 (OE# Control) I27
TIMING DIAGRAMS (Continued) I28
 Synchronous Read Timing #2 (CE# Control) I28
TIMING DIAGRAMS (Continued) I29
 Synchronous Read Timing #3 (ADV# Control) I29
TIMING DIAGRAMS (Continued) I30
 Synchronous Write Timing #1 (WE# Level Control) I30
TIMING DIAGRAMS (Continued) I31
 Synchronous Write Timing #2 (WE# Single Clock Pulse Control) I31
TIMING DIAGRAMS (Continued) I32
 Synchronous Write Timing #3 (ADV# Control) I32
TIMING DIAGRAMS (Continued) I33
 Synchronous Write Timing #4 (WE# Level Control, Single Write) I33
TIMING DIAGRAMS (Continued) I34
 Synchronous Read to Write Timing #1 (CE# Control) I34
TIMING DIAGRAMS (Continued) I35
 Synchronous Read to Write Timing #2 (ADV# Control) I35
TIMING DIAGRAMS (Continued) I36
 Synchronous Write to Read Timing #1 (CE# Control) I36
TIMING DIAGRAMS (Continued) I37
 Synchronous Write to Read Timing #2 (ADV# Control) I37
TIMING DIAGRAMS (Continued) I38
 POWER-UP Timing #1 I38
 POWER-UP Timing #2 I38
TIMING DIAGRAMS (Continued) I39
 POWER DOWN Entry and Exit Timing I39
 Standby Entry Timing after Read or Write I39
TIMING DIAGRAMS (Continued) I40
 Configuration Register Set Timing #1 (Asynchronous Operation) I40
TIMING DIAGRAMS (Continued) I41
 Configuration Register Set Timing #2 (Synchronous Operation) I41

Revision Summary

Block Diagrams

MCP Block Diagram of S71WS512NE0BFWZZ

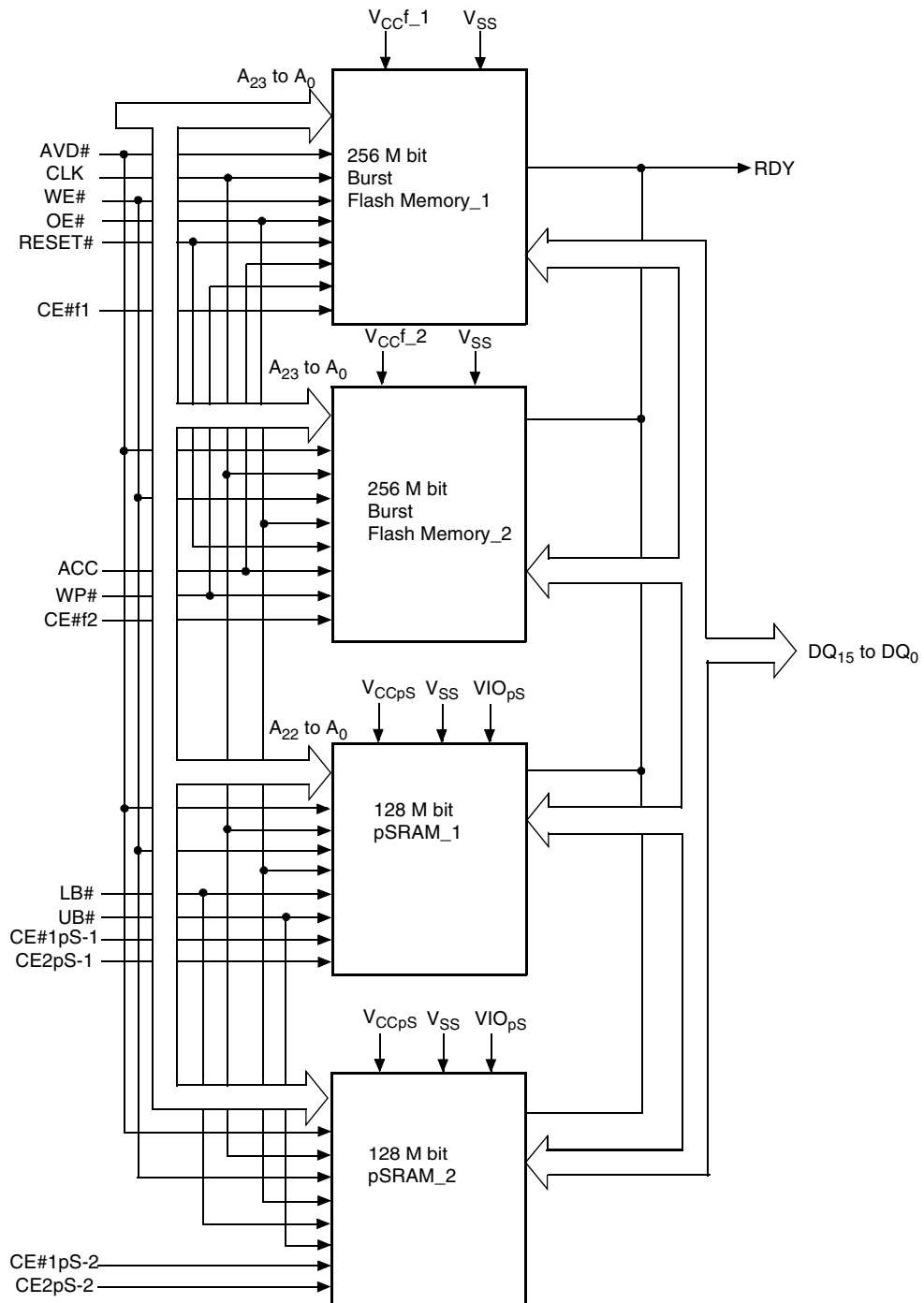

Connection Diagrams

Connection Diagram of S71WS5I2NE0BFWZZ

96-Ball FBGA
Top View

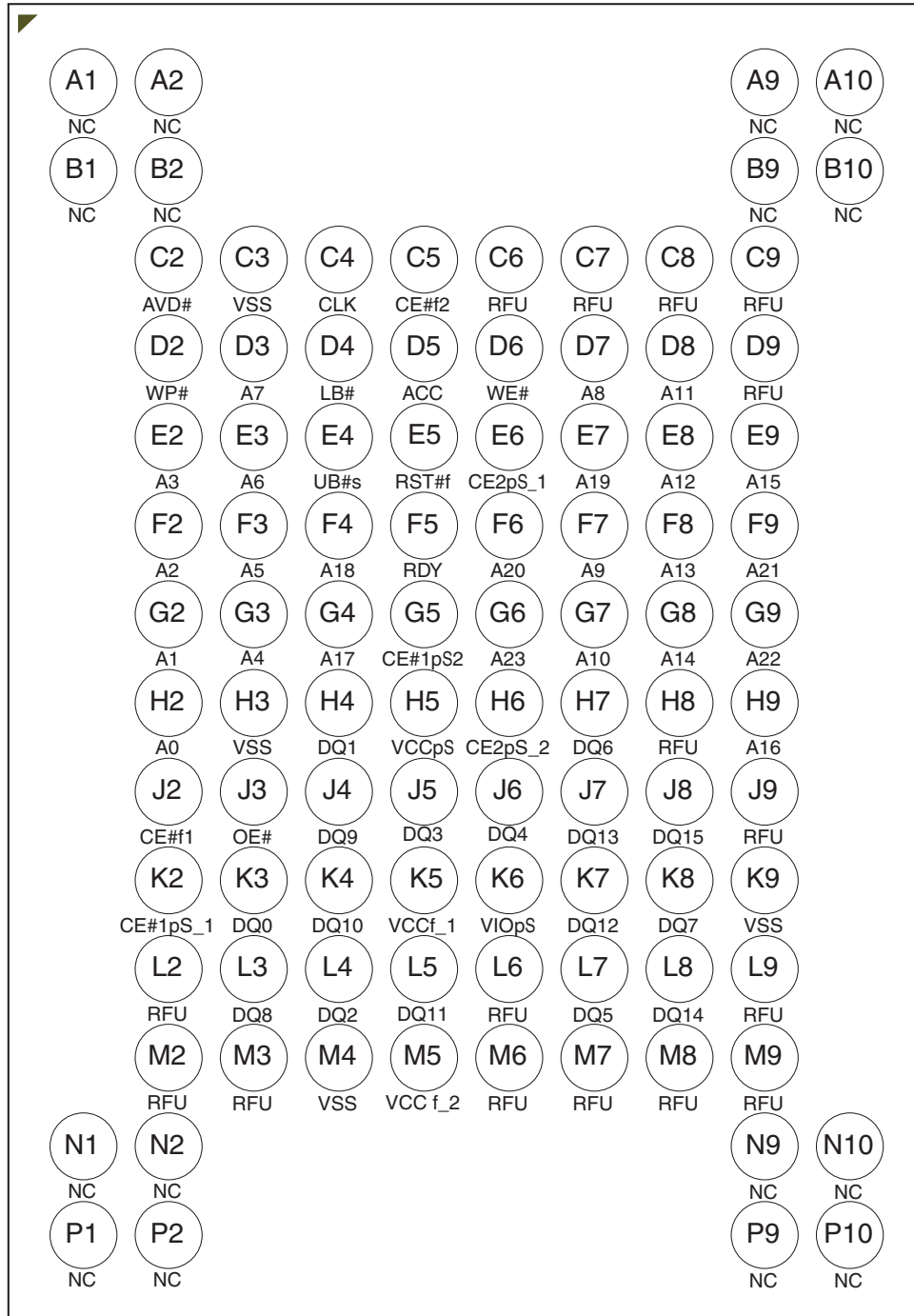

Special Package Handling Instructions

Special handling is required for Flash Memory products in molded packages (FBGA). The package and/or data integrity may be compromised if the package body is exposed to temperatures above 150°C for prolonged periods of time.

Pin Description

A22-A0	=	23 Address Inputs (Common)
A23	=	1 Address Inputs (Flash)
DQ15-DQ0	=	16 Data Inputs/Outputs (Common)
CE#f	=	Chip Enable (Flash)
CE#1pS	=	Chip Enable1 (pSRAM)
CE#2pS	=	Chip Enable2 (pSRAM)
OE#	=	Output Enable (Common)
WE#	=	Write Enable (Common)
RDY	=	Ready Output
CLK	=	Clock Input
AVD#	=	Address Valid Input
UB#	=	Upper Byte Control (SRAM)
LB#	=	Lower Byte Control (SRAM)
RESET#	=	Hardware Reset Pin, Active Low (Flash)
WP#	=	Hardware Write Protect (Flash)
ACC	=	Acceleration pin (Flash)
V _{CCf}	=	Flash 1.8 volt-only single power supply (see Product Selector Guide for speed options and voltage supply tolerances)
V _{CCpS}	=	pSRAM Power Supply
V _{IOpS}	=	pSRAM Output buffer Power Supply
V _{SS}	=	Device Ground (Common)
NC	=	Pin Not Connected Internally
RFU	=	Reserved for Future Use

Logic Symbol

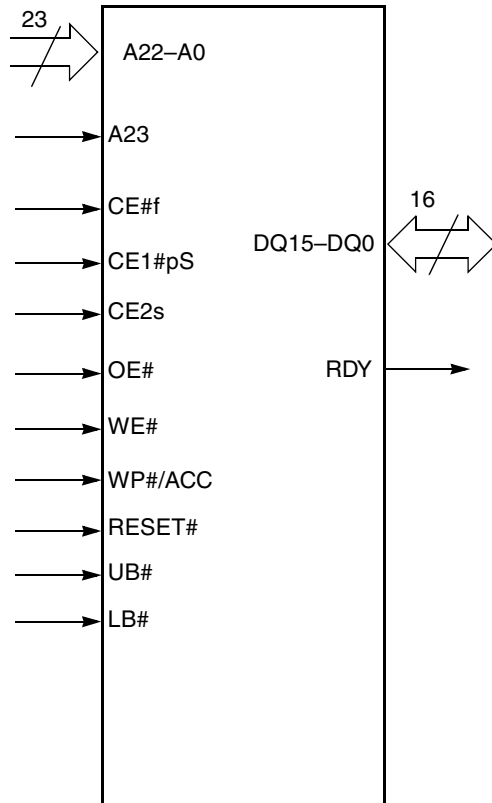

■ NOR Flash and pSRAM and DATA STORAGE densities up to 4 Gigabits

The signal locations of the resultant MCP device are shown above. Note that for different densities, the actual package outline may vary. Any pinout in any MCP, however, will be a subset of the pinout above.

In some cases, there may be outrigger balls in locations outside the grid shown above. In such cases, the user is recommended to treat them as reserved and not connect them to any other signal.

For any further inquiries about the above look-ahead pinout, please refer to the application note on this subject or contact your sales office.

Device Bus Operation

Table I. Device Bus Operations

Operation (Asynchronous) - Flash	CE#f1	CE#f2	CE#pS_1	CE2pS_1	CE#pS_2	CE2pS_2	OE#	WE#	Addr	DQI5-DQ0	UB#	LB#	RESET#	WP#	ACC#	CLK(See Note)	AVD#
Read - Address Latched	L	H	H	L	H	L	L	H	Valid	Valid	X	X	H	H	H	X	
	H	L	H	H	H	H											
Read - Address Steady State	L	H	H	L	H	L	L	H	Valid	Valid	X	X	H	H	H	X	L
	H	L	H	H	H	H											
Write	L	H	H	L	H	L	H	L	Valid	Valid	X	X	H	H	H	X	L
	H	L	H	H	H	H											
Standby	H	H	H	H	H	H	X	X	X	High-Z	X	X	H	H	H	X	X
Reset	X	X	X	X	X	X	X	X	X	High-Z	X	X	L	H	H	X	X
Output Disable	H	H	L	H	H	H	H	H	X	X	X	X	H	H	H	X	X
	H	L	H	H	H												
	L	H	H	H	H												

Operation(Synchronous) - Flash	CE#f1	CE#f2	CE#pS_1	CE2pS_1	CE#pS_2	CE2pS_2	OE#	WE#	Addr	DQI5-DQ0	UB#	LB#	RESET#	WP#	ACC#	CLK(See Note)	AVD#
Load Starting Burst Address	L	H	H	L	H	L	X	H	Valid	Data	X	X	H	H	H		
	H	L	H	H	H	H											
Advance Burst Read to Next Address	L	H	H	L	H	L	L	H	X	Data	X	X	H	H	H		H
	H	L	H	H	H	H											
Terminate current Burst read cycle	H	H	H	H	H	H	X	H	X	High-Z	X	X	H	H	H		X
"Terminate current Burst read cycle via RESET#"	X	X	X	X	X	X	X	H	X	High-Z	X	X	L	H	H	X	X
"Terminate current Burst read cycle and start new Burst read cycle"	L	H	H	L	H	L	X	H	Valid	Valid	X	X	H	H	H		
	H	L	H	H	H	H											

Operation (Asynchronous) - pSRAM	CE#f1	CE#f2	CE#pS_1	CE2pS_1	CE#pS_2	CE2pS_2	OE#	WE#	Addr	DQI5-DQ0	UB#	LB#	RESET#	WP#	ACC#	CLK(See Note)	AVD#
Read	H	H	L	H	H	H	L	H	Valid	Valid	L	L	H	H	H	X	H/L
	H	H	H	H	L	H											
Read (Page)	H	H	L	H	H	H	L	H	Valid	Valid	H/L	H/L	H	H	H	X	H/L
	H	H	H	H	L	H											
Write	H	H	L	H	H	H	H	L	Valid	Valid	L	L	H	H	H	X	*note
	H	H	H	H	L	H											
Write(Upper Byte)	H	H	L	H	H	H	H	L	Valid	Invalid(DQ0-8)	L	H	H	H	H	X	*note
	H	H	H	H	L	H				Valid(DQ9-15)							
Write(Lower Byte)	H	H	L	H	H	H	H	L	Valid	Valid(DQ0-8)	H	L	H	H	H	X	*note
	H	H	H	H	L	H				Invalid(DQ9-15)							
Standby	H	H	H	H	H	H	H	H	X	High-Z	X	X	H	H	H	X	*note
PowerDown	H	H	X	L	X	L	X	X	X	High-Z	X	X	H	H	H	X	X
Output Disable	H	H	L	H	L	H	H	H	X	X	X	X	H	H	H	X	*note

Operation(Synchronous) - pSRAM	CE#f1	CE#f2	CE#pS_1	CE2pS_1	CE#pS_2	CE2pS_2	OE#	WE#	Addr	DQI5-DQ0	UB#	LB#	RESET#	WP#	ACC#	CLK(See Note)	AVD#
Load Starting Burst Address	H	H	H	L	H	H	X	H	Valid	Data	X	X	H	H	H		
	H	H	H	H	H	L											
Advance Burst Read to Next Address	H	H	H	L	H	H	L	H	X	Data	X	X	H	H	H		H
	H	H	H	H	H	L											
Terminate current Burst read cycle	H	H	H	H	H	H	X	H	X	High-Z	X	X	H	H	H		X
"Terminate current Burst read cycle and start new Burst read cycle"	H	H	H	L	H	L	X	H	Valid	Valid	X	X	H	H	H		
	H	H	H	H	H	H											

Legend: L = Logic 0, H = Logic 1, X = Don't Care.

Note: Default active edge of CLK is the rising edge. Ordering Information

The order number (Valid Combination) is formed by the following:

S 71 W S 512 N E 0 B F W ZZ 0

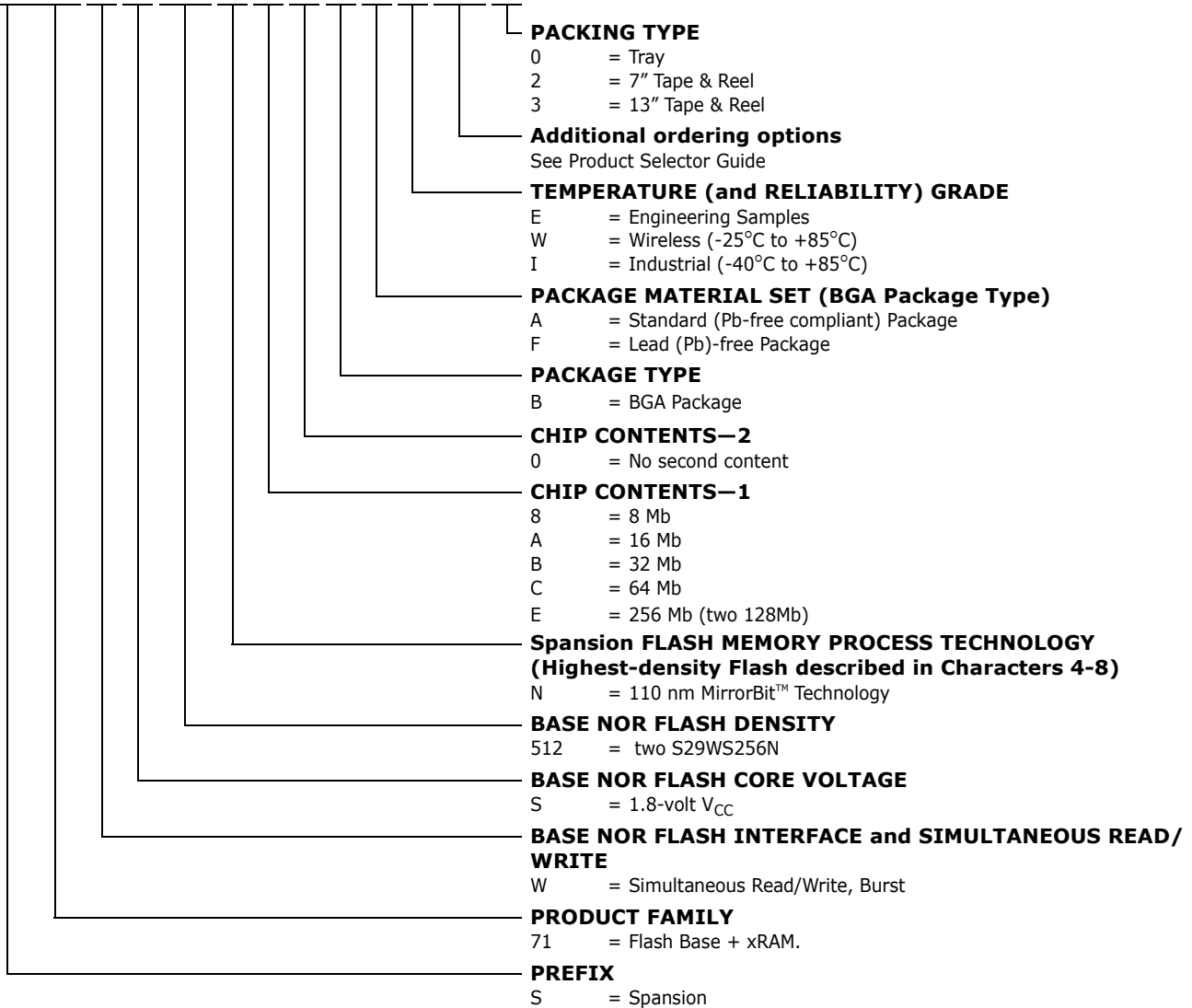

Valid Combinations

Valid Combinations list configurations planned to be supported in volume for this device. Consult the local sales office to confirm availability of specific valid combinations and to check on newly released combinations.

Valid Combinations		Flash Access Time (MHz)	(p)SRAM Access Time (MHz)	Temperature Range	Supplier
Order Number	Package Marking				
S71WS512NE0BFWZZ	71WS512NE0BFWZZ	54	54	-25C to +85C	Supplier 1

Pin Capacitance

Symbol	Parameter	Test Condition	Typ	Max	Unit
C_{IN1}	Input Capacitance	$V_{IN}=0$	TBD	TBD	pF
C_{IN2}	Output Capacitance	$V_{out}=0$	TBD	TBD	pF
C_{out}	Control Capacitance	$V_{IN}=0$	TBD	TBD	pF

Physical Dimensions TBD

XXX

S29WSxxxN MirrorBit™ Flash Family For Multi-chip Products (MCP)

S29WS256N

256 Megabit (16 M x 16-Bit) CMOS 1.8 Volt-only Simultaneous Read/Write, Burst Mode Flash Memory

Distinctive Characteristics

Architectural Advantages

- **Single 1.8 volt read, program and erase (1.65 to 1.95 volt)**
- **Manufactured on 110 nm MirrorBit™ process technology**
- **Simultaneous Read/Write operation**
 - Data can be continuously read from one bank while executing erase/program functions in another bank
 - Zero latency between read and write operations
 - Sixteen bank architecture: Each bank consists of 16Mb (WS256N)
- **Programmable Burst Interface**
 - 2 Modes of Burst Read Operation
 - Linear Burst: 32, 16, and 8 words with or without wrap-around
 - Continuous Sequential Burst
- **SecSi™ (Secured Silicon) Sector region**
 - 256 words accessible through a command sequence, 128 words for the Factory SecSi Sector and 128 words for the Customer SecSi Sector.
- **Sector Architecture**
 - S29WS256N: Eight 16 Kword sectors and two-hundred-fifty-four 64 Kword sectors
 - Banks 0 and 15 each contain 16 Kword sectors and 64 Kword sectors; Other banks each contain 64 Kword sectors
 - Eight 16 Kword boot sectors, four at the top of the address range, and four at the bottom of the address range
- **100,000 erase cycles per sector typical**
- **20-year data retention typical**

Performance Characteristics

- **Read access times at 66/54 MHz @ 1.8V V_{IO} (1.65 - 1.95V)**
 - Burst access times of 11.2/13.5 ns for 1.8V V_{IO} (@ 30 pF at industrial temperature range)
 - Synchronous initial latency of 69/69 ns for 1.8V V_{IO} (@ 30 pF at industrial temperature range)
 - Asynchronous random access times of 70/70 ns for 1.8V V_{IO} (@ 30 pF at industrial temperature range)
- **High Performance**
 - Typical word programming time of < 40 μs
 - Typical effective word programming time of <9.4 μs utilizing a 32-Word Write Buffer at V_{cc} Level
 - Typical effective word programming time of <4 μs utilizing a 32-Word Write Buffer at ACC Level
 - Typical sector erase time of <150 ms for both 16 Kword sectors and <400 ms sector erase time for 64 Kword sectors

- **Power dissipation (typical values, C_L = 30 pF) @ 66 MHz**

- Continuous Burst Mode Read: <28 mA
- Simultaneous Operation: <50 mA
- Program: <35 mA
- Erase: <35 mA
- Standby mode: <20 μA

Hardware Features

- **Sector Protection**
 - Write protect (WP#) function allows protection of eight outermost boot sectors, four at top and four at bottom of memory, regardless of sector protect status
- **Handshaking feature available**
 - Provides host system with minimum possible latency by monitoring RDY
- **Hardware reset input (RESET#)**
 - Hardware method to reset the device for reading array data
- **Boot Option**
 - Dual Boot
- **CMOS compatible inputs, CMOS compatible outputs**
- **Low V_{CC} write inhibit**

Security Features

- **Advanced Sector Protection consists of the two following modes of operation**
- **Persistent Sector Protection**
 - A command sector protection method to lock combinations of individual sectors to prevent program or erase operations within that sector
 - Sectors can be locked and unlocked in-system at V_{CC} level
- **Password Sector Protection**
 - A sophisticated sector protection method to lock combinations of individual sectors to prevent program or erase operations within that sector using a user-defined 64-bit password

Software Features

- **Supports Common Flash Memory Interface (CFI)**
- **Software command set compatible with JEDEC 42.4 standards**
- **Data# Polling and toggle bits**
 - Provides a software method of detecting program and erase operation completion

■ Erase Suspend/Resume

- Suspends an erase operation to read data from, or program data to, a sector that is not being erased, then resumes the erase operation

■ Program Suspend/Resume

- Suspends a programming operation to read data from a sector other than the one being programmed, then resume the programming operation

■ Unlock Bypass Program command

- Reduces overall programming time when issuing multiple program command sequences

Additional Features**■ Program Operation**

- Ability to perform synchronous and asynchronous program operation independent of burst control register setting

■ ACC input pin

- Acceleration function reduces programming time in a factory setting.

General Description

The WSxxxN is a 256 Mbit, 1.8 Volt-only, simultaneous Read/Write, Burst Mode Flash memory device, organized as 16 Mwords of 16 bits. This device uses a single V_{CC} of 1.65 to 1.95 V to read, program, and erase the memory array. A 9.0-volt V_{HH} on ACC may be used for faster program performance if desired. The device can be programmed in standard EPROM programmers.

At 66 MHz and 1.8V V_{IO} , the device provides a burst access of 11.2 ns at 30 pF with an initial latency of 69 ns at 30 pF. At 54 MHz and 1.8V V_{IO} , the device provides a burst access of 13.5 ns at 30 pF with an initial latency of 69 ns at 30 pF. The device operates within the industrial temperature range of -40°C to +85°C or wireless temperature range of -25°C to +80°C. These devices are offered in MCP compatible FBGA packages. See the product selector guide for details

The Simultaneous Read/Write architecture provides **simultaneous operation** by dividing the memory space into sixteen banks. The device can improve overall system performance by allowing a host system to program or erase in one bank, then immediately and simultaneously read from another bank, with zero latency. This releases the system from waiting for the completion of program or erase operations.

The device is divided as shown in the following table:

Bank	Quantity of Sectors (WS256N)	Sector Size
0	4/4/4	16 Kwords
	15/7/3	64 Kwords
1	16/8/4	64 Kwords
2	16/8/4	64 Kwords
3	16/8/4	64 Kwords
4	16/8/4	64 Kwords
5	16/8/4	64 Kwords
6	16/8/4	64 Kwords
7	16/8/4	64 Kwords
8	16/8/4	64 Kwords
9	16/8/4	64 Kwords
10	16/8/4	64 Kwords
11	16/8/4	64 Kwords
12	16/8/4	64 Kwords
13	16/8/4	64 Kwords
14	16/8/4	64 Kwords
15	15/7/3	64 Kwords
	4/4/4	16 Kwords

The VersatileIO™ (V_{IO}) control allows the host system to set the voltage levels that the device generates at its data outputs and the voltages tolerated at its data inputs to the same voltage level that is asserted on the V_{IO} pin.

The device uses Chip Enable (CE#), Write Enable (WE#), Address Valid (AVD#) and Output Enable (OE#) to control asynchronous read and write operations. For burst operations, the device additionally requires Ready (RDY), and Clock (CLK). This implementation allows easy interface with minimal glue logic to a

wide range of microprocessors/microcontrollers for high performance read operations.

The burst read mode feature gives system designers flexibility in the interface to the device. The user can preset the burst length and then wrap or non-wrap through the same memory space, or read the flash array in continuous mode.

The clock polarity feature provides system designers a choice of active clock edges, either rising or falling. The active clock edge initiates burst accesses and determines when data will be output.

The device is entirely command set compatible with the **JEDEC 42.4 single-power-supply Flash standard**. Commands are written to the command register using standard microprocessor write timing. Register contents serve as inputs to an internal state-machine that controls the erase and programming circuitry. Write cycles also internally latch addresses and data needed for the programming and erase operations. Reading data out of the device is similar to reading from other Flash or EPROM devices.

Device programming occurs by executing the program command sequence. This initiates the **Write Buffer Programming** algorithm - an internal algorithm that automatically times the program pulse widths and verifies proper cell margin. This feature provides superior programming performance by grouping locations being programmed. The **Unlock Bypass** mode facilitates faster program times by requiring only two write cycles to program data instead of four.

Device erasure occurs by executing the erase command sequence. This initiates the **Embedded Erase** algorithm - an internal algorithm that automatically pre-programs the array (if it is not already programmed) before executing the erase operation. During erase, the device automatically times the erase pulse widths and verifies proper cell margin.

The **Program Suspend/Program Resume** feature enables the user to put program on hold for any period of time to read data from any sector that is not selected for programming. If a read is needed from the SecSi Sector area (One Time Program area), Persistent Protection area, Dynamic Protection area, or the CFI area, after an program suspend, then the user must use the proper command sequence to enter and exit this region. The program suspend/resume functionality is also available when programming in erase suspend (1 level depth only).

The **Erase Suspend/Erase Resume** feature enables the user to put erase on hold for any period of time to read data from, or program data to, any sector that is not selected for erasure. True background erase can thus be achieved. If a read is needed from the SecSi Sector area (One Time Program area), Persistent Protection area, Dynamic Protection area, or the CFI area, after an erase suspend, then the user must use the proper command sequence to enter and exit this region.

The **hardware RESET# pin** terminates any operation in progress and resets the internal state machine to reading array data. The RESET# pin may be tied to the system reset circuitry. A system reset would thus also reset the device, enabling the system microprocessor to read boot-up firmware from the Flash memory device.

The host system can detect whether a program or erase operation is complete by using the device status bit DQ7 (Data# Polling), DQ6/DQ2 (toggle bits), DQ5 (exceeded timing limit), DQ3 (sector erase timer), and DQ1 (write to buffer abort). After a program or erase cycle has been completed, the device automatically returns to reading array data.

The **sector erase architecture** allows memory sectors to be erased and reprogrammed without affecting the data contents of other sectors. The device is fully erased when shipped from the factory.

Hardware data protection measures include a low V_{CC} detector that automatically inhibits write operations during power transitions. The device also offers two types of data protection at the sector level. When at V_{IL} , **WP#** locks the four outermost boot sectors at the top of memory and four outermost boot sectors at the bottom of memory.

When the ACC pin = V_{IL} , the entire flash memory array is protected.

The device offers two power-saving features. When addresses have been stable for a specified amount of time, the device enters the **automatic sleep mode**. The system can also place the device into the **standby mode**. Power consumption is greatly reduced in both modes.

Spansion™ Flash memory products combine years of Flash memory manufacturing experience to produce the highest levels of quality, reliability and cost effectiveness. The device electrically erases all bits within a sector simultaneously via Fowler-Nordheim tunnelling. The data is programmed using hot electron injection.

Product Selector Guide

Part Number	S29WS256N	
V _{IO} Option	1.65–1.95 V	
Speed Option (Burst Frequency) (Note 1)	66 MHz	54 MHz
Max Synchronous Latency, ns (t_{IACC})	69	69
Max Synchronous Burst Access Time, ns (t_{BACC})	11.2	13.5
Max Asynchronous Access Time t_{CE} , ns	70	70
Max CE# Access Time, ns (t_{CE}), ns	70	70
Max OE# Access Time, ns (t_{OE})	11.2	13.5

Block Diagram

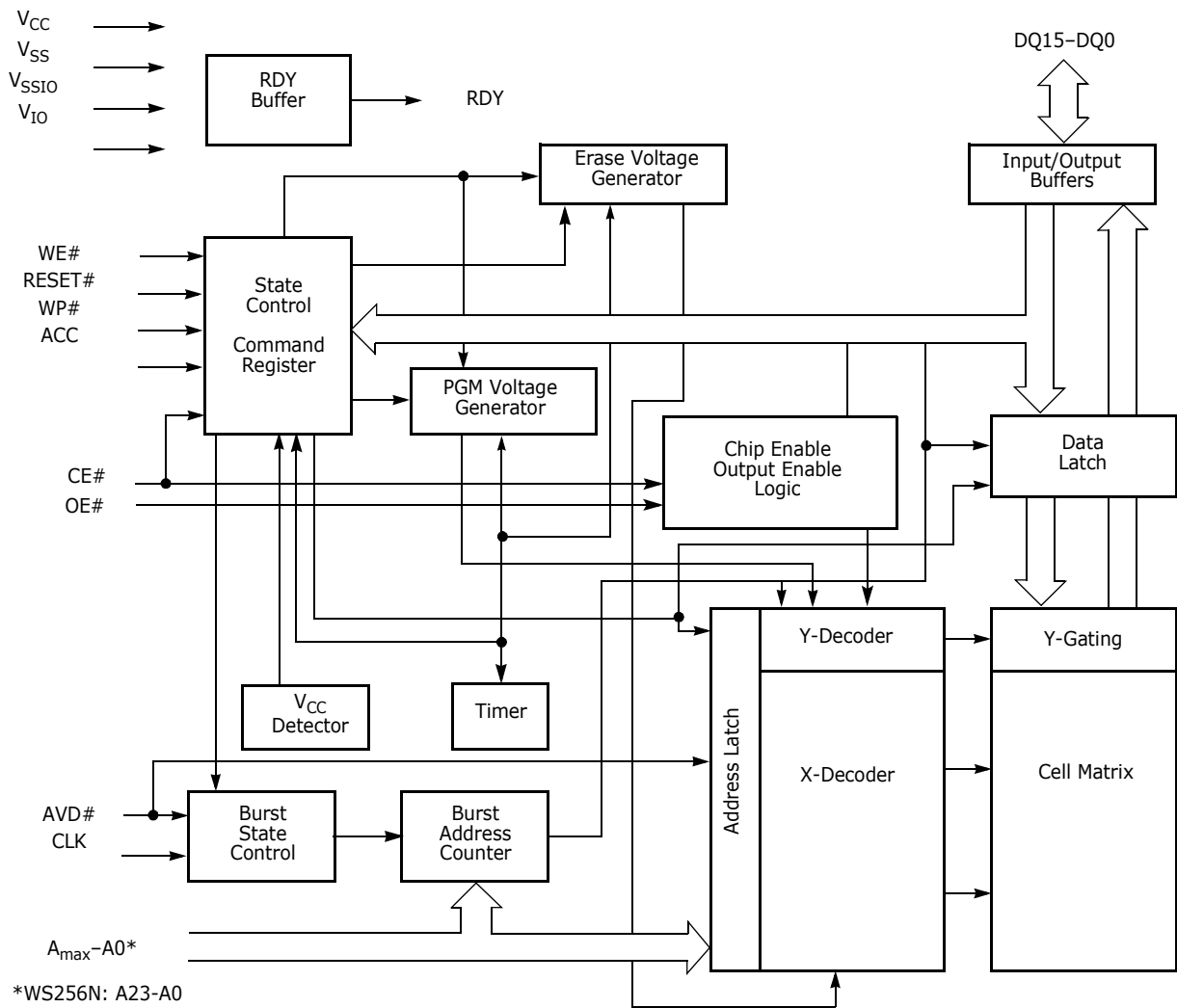

Block Diagram of Simultaneous Operation Circuit

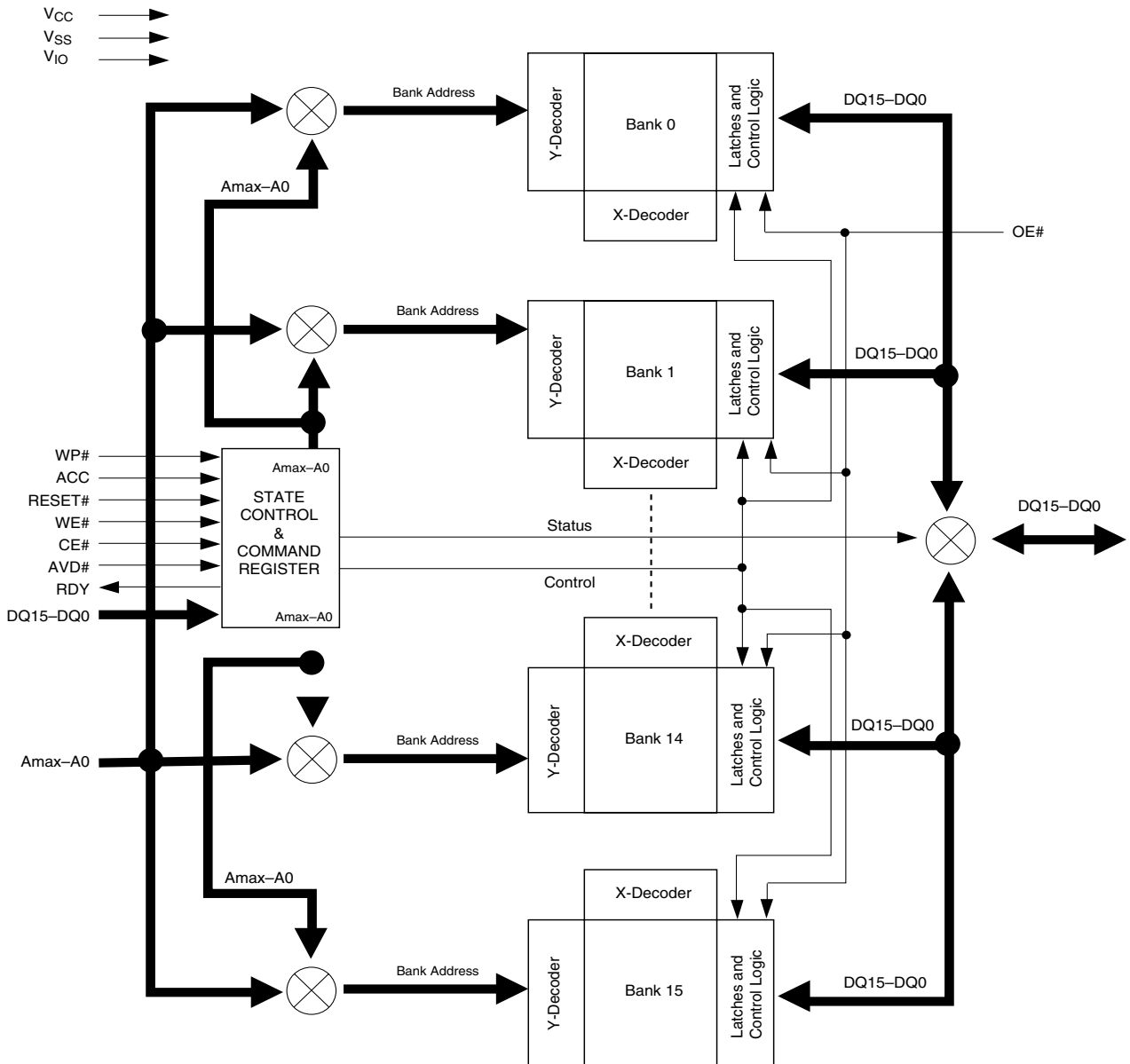

Notes: Amax=A23 for the WS256N.

Input/Output Descriptions

A23-A0	=	Address inputs for WS256N
DQ15-DQ0	=	Data input/output
CE#	=	Chip Enable input. Asynchronous relative to CLK for the Burst mode.
OE#	=	Output Enable input. Asynchronous relative to CLK for the Burst mode.
WE#	=	Write Enable input.
V _{CC}	=	Device Power Supply (1.65 – 1.95 V).
V _{IO}	=	Input & Output Buffer Power Supply (1.35 – 1.70 V).
V _{SS}	=	Ground
V _{SSIO}	=	Output Buffer Ground
NC	=	No Connect; not connected internally
RDY	=	Ready output. Indicates the status of the Burst read.
CLK	=	Clock input. In burst mode, after the initial word is output, subsequent active edges of CLK increment the internal address counter. Should be at V _{IL} or V _{IH} while in asynchronous mode
AVD#	=	Address Valid input. Indicates to device that the valid address is present on the address inputs. Low = for asynchronous mode, indicates valid address; for burst mode, causes starting address to be latched. High = device ignores address inputs
RESET#	=	Hardware reset input. Low = device resets and returns to reading array data
WP#	=	Hardware write protect input. At V _{IL} , disables program and erase functions in the four outermost sectors. Should be at V _{IH} for all other conditions.
ACC	=	Accelerated input. At V _{HH} , accelerates programming; automatically places device in unlock bypass mode. At V _{IL} , disables all program and erase functions. Should be at V _{IH} for all other conditions.

Logic Symbol

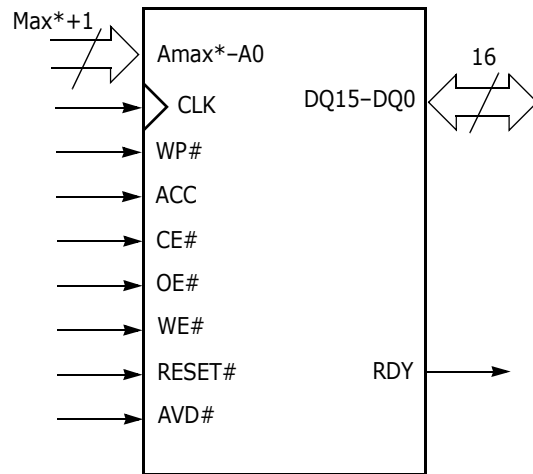

* max=23 for the WS256N.

Device Bus Operations

This section describes the requirements and use of the device bus operations, which are initiated through the internal command register. The command register itself does not occupy any addressable memory location. The register is composed of latches that store the commands, along with the address and data information needed to execute the command. The contents of the register serve as inputs to the internal state machine. The state machine outputs dictate the function of the device. Table 2 lists the device bus operations, the inputs and control levels they require, and the resulting output. The following subsections describe each of these operations in further detail.

Table 2. Device Bus Operations

Operation	CE#	OE#	WE#	Addresses	DQ15–0	RESET#	CLK (See Note)	AVD#
Asynchronous Read - Addresses Latched	L	L	H	Addr In	I/O	H	X	
Asynchronous Read - Addresses Steady State	L	L	H	Addr In	I/O	H	X	L
Asynchronous Write	L	H	L	Addr In	I/O	H	X	L
Synchronous Write	L	H	L	Addr In	I/O	H		
Standby (CE#)	H	X	X	X	HIGH Z	H	X	X
Hardware Reset	X	X	X	X	HIGH Z	L	X	X
Burst Read Operations (Synchronous)								
Load Starting Burst Address	L	X	H	Addr In	X	H		
Advance Burst to next address with appropriate Data presented on the Data Bus	L	L	H	X	Burst Data Out	H		H
Terminate current Burst read cycle	H	X	H	X	HIGH Z	H		X
Terminate current Burst read cycle via RESET#	X	X	H	X	HIGH Z	L	X	X
Terminate current Burst read cycle and start new Burst read cycle	L	X	H	Addr In	I/O	H		

Legend: L = Logic 0, H = Logic 1, X = Don't Care.

Note: Default active edge of CLK is the rising edge.

Requirements for Asynchronous Read Operation (Non-Burst)

To read data from the memory array, the system must first assert a valid address on A23–A0 for WS256N, while driving AVD# and CE# to V_{IL} . WE# should remain at V_{IH} . The rising edge of AVD# latches the address. The data will appear on DQ15–DQ0. Since the memory array is divided into sixteen banks, each bank remains enabled for read access until the command register contents are altered.

Address access time (t_{ACC}) is equal to the delay from stable addresses to valid output data. The chip enable access time (t_{CE}) is the delay from the stable addresses and stable CE# to valid data at the outputs. The output enable access time (t_{OE}) is the delay from the falling edge of OE# to valid data at the output.

The internal state machine is set for reading array data in asynchronous mode upon device power-up, or after a hardware reset. This ensures that no spurious alteration of the memory content occurs during the power transition.

Requirements for Synchronous (Burst) Read Operation

The device is capable of continuous sequential burst read and linear burst read of a preset length. When the device first powers up, it is enabled for asynchronous read operation.

Prior to entering burst mode, the system should determine how many wait states are desired for the initial word (t_{IACC}) of each burst access, what mode of burst operation is desired, which edge of the clock will be the active clock edge, and how the RDY signal will transition with valid data. The system would then write the configuration register command sequence. See "Set Configuration Register Command Sequence" section for further details.

Once the system has written the "Set Configuration Register" command sequence, the device is enabled for synchronous reads only.

The initial word is output t_{IACC} after the active edge of the first CLK cycle. Subsequent words are output t_{BACC} after the active edge of each successive clock cycle at which point the internal address counter is automatically incremented. Note that the device has a fixed internal address boundary that occurs every 128 words, starting at address 00007Fh. No boundary crossing latency is required when the device operates at or below 66 MHz to reach address 000080h. When the device operates above 66 MHz, a boundary crossing of one additional wait state is required. The timing diagram can be found in Figure 28.

When the starting burst address is not divisible by four, additional waits are required. For example, if the starting burst address is divisible by four $A1:0 = 00$, no additional wait state is required, but if the starting burst address is at address $A1:0 = 01, 10, \text{ or } 11$, one, two or three wait states are required, respectively, until data DQ4 is read. The RDY output indicates this condition to the system by deasserting (see Table 3 and Table 13).

Table 3. Address Dependent Additional Latency

Initial Address A[10]	Cycle						
	X	X+1	X+2	X+3	X+4	X+5	X+6
00	DQ0	DQ1	DQ2	DQ3	DQ4	DQ5	DQ6
01	DQ1	DQ2	DQ3	--	DQ4	DQ5	DQ6
10	DQ2	DQ3	--	--	DQ4	DQ5	DQ6
11	DQ3	--	--	--	DQ4	DQ5	DQ6

Continuous Burst

The device will continue to output sequential burst data, wrapping around to address 000000h after it reaches the highest addressable memory location, until the system drives CE# high, RESET# low, or AVD# low in conjunction with a new address. See Table 2.

If the host system crosses a bank boundary while reading in burst mode, and the subsequent bank is not programming or erasing, a one-cycle latency is required as described above if the device is operating above 66 MHz. If the device is operating at or below 66 MHz, no boundary crossing latency is required. If the host system crosses the bank boundary while the subsequent bank is programming or erasing, the device will provide read status information. The clock will be ignored. After the host has completed status reads, or the device has completed the program or erase operation, the host can restart a burst operation using a new address and AVD# pulse.

8-, 16-, and 32-Word Linear Burst with Wrap Around

The remaining three burst read modes are of the linear wrap around design, in which a fixed number of words are read from consecutive addresses. In each of these modes, the burst addresses read are determined by the group within which the starting address falls. The groups are sized according to the number of words read in a single burst sequence for a given mode (see [Table 4.](#))

Table 4. Burst Address Groups

Mode	Group Size	Group Address Ranges
8-word	8 words	0-7h, 8-Fh, 10-17h,...
16-word	16 words	0-Fh, 10-1Fh, 20-2Fh,...
32-word	32 words	00-1Fh, 20-3Fh, 40-5Fh,...

For example, if the starting address in the 8-word mode is 39h, the address range to be read would be 38-3Fh, and the burst sequence would be 39-3A-3B-3C-3D-3E-3F-38h if wrap around is enabled. The burst sequence begins with the starting address written to the device, but wraps back to the first address in the selected group. In a similar fashion, the 16-word and 32-word Linear Wrap modes begin their burst sequence on the starting address written to the device, and then wrap back to the first address in the selected address group. **Note that in these three burst read modes the address pointer does not cross the boundary that occurs every 128 words; thus, no wait states are inserted (except during the initial access).** (See [Figure 15](#))

8-, 16-, and 32-Word Linear Burst without Wrap Around

If wrap around is not enabled, 8-word, 16-word, or 32-word burst will execute linearly up to the maximum memory address of the selected number of words. The burst will stop after 8, 16, or 32 addresses and will not wrap around to the first address of the selected group. For example: if the starting address in the 8-word mode is 39h, the address range to be read would be 39-40h, and the burst sequence would be 39-3A-3B-3C-3D-3E-3F-40 if wrap around is not enabled. The next address to be read will require a new address and AVD# pulse.

The RDY pin indicates when data is valid on the bus.

Configuration Register

The device uses a configuration register to set the various burst parameters: number of wait states, burst read mode, active clock edge, RDY configuration, and synchronous mode active. For more information, see [Table 16](#).

Handshaking

The device is equipped with a handshaking feature that allows the host system to simply monitor the RDY signal from the device to determine when the burst data is ready to be read. The host system should use the programmable wait state configuration to set the number of wait states for optimal burst mode operation. The initial word of burst data is indicated by the rising edge of RDY after OE# goes low.

For optimal burst mode performance, the host system must set the appropriate number of wait states in the flash device depending on clock frequency. See the "[Set Configuration Register Command Sequence](#)" section and the "[Requirements for Synchronous \(Burst\) Read Operation](#)" section for more information.

Simultaneous Read/Write Operations with Zero Latency

This device is capable of reading data from one bank of memory while programming or erasing in another bank of memory. An erase operation may also be suspended to read from or program to another location within the same bank (except the sector being erased). [Figure 31](#) shows how read and write cycles may be initiated for simultaneous operation with zero latency. Refer to the DC Characteristics table for read-while-program and read-while-erase current specifications.

Writing Commands/Command Sequences

The device has the capability of performing an asynchronous or synchronous write operation. While the device is configured in Asynchronous read it is able to perform Asynchronous write operations only. CLK is ignored when the device is configured in the Asynchronous mode. When in the Synchronous read mode configuration, the device is able to perform both Asynchronous and Synchronous write operations. CLK and AVD# induced address latches are supported in the Synchronous programming mode. During a synchronous write operation, to write a command or command sequence (which includes programming data to the device and erasing sectors of memory), the system must drive AVD# and CE# to V_{IL} , and OE# to V_{IH} when providing an address to the device, and drive WE# and CE# to V_{IL} , and OE# to V_{IH} when writing commands or data. During an asynchronous write operation, the system must drive CE# and WE# to V_{IL} and OE# to V_{IH} when providing an address, command, and data. Addresses are latched on the last falling edge of WE# or CE#, while data is latched on the 1st rising edge of WE# or CE# (see [Table 16](#)).

An erase operation can erase one sector, multiple sectors, or the entire device. [Table 12](#) indicates the address space that each sector occupies. The device address space is divided into sixteen banks: Banks 1 through 14 contain only 64 Kword sectors, while Banks 0 and 15 contain both 16 Kword boot sectors in addition to 64 Kword sectors. A "bank address" is the set of address bits required to uniquely select a bank. Similarly, a "sector address" is the address bits required to uniquely select a sector.

I_{CC2} in "DC Characteristics" represents the active current specification for the write mode. "AC Characteristics—Synchronous" and "AC Characteristics—Asynchronous" contain timing specification tables and timing diagrams for write operations.

Unlock Bypass Mode

The device features an Unlock Bypass mode to facilitate faster programming. Once the device enters the Unlock Bypass mode, only two write cycles are required to program a set of words, instead of four. See the "Unlock Bypass Command Sequence" section for more details.

Accelerated Program/Erase Operations

The device offers accelerated program and accelerated chip erase operations through the ACC function. ACC is intended to allow faster manufacturing throughput at the factory and not to be used in system operations.

If the system asserts V_{HH} on this input, the device automatically enters the aforementioned Unlock Bypass mode and uses the higher voltage on the input to reduce the time required for program and erase operations. The system can then use the Write Buffer Load command sequence provided by the Unlock Bypass mode. Note that if a "Write-to-Buffer-Abort Reset" is required while in Unlock By-

pass mode, the **full 3-cycle RESET command sequence must be used to reset the device**. Removing V_{HH} from the ACC input, upon completion of the embedded program or erase operation, returns the device to normal operation. Note that sectors must be unlocked prior to raising ACC to V_{HH} . *Note that the ACC pin must not be at V_{HH} for operations other than accelerated programming and accelerated chip erase, or device damage may result. In addition, the ACC pin must not be left floating or unconnected; inconsistent behavior of the device may result.*

When at V_{IL} , ACC locks all sectors. ACC should be at V_{IH} for all other conditions.

Write Buffer Programming Operation

Write Buffer Programming allows the system to write a maximum of **32** words in one programming operation. This results in a faster effective word programming time than the standard "word" programming algorithms. The Write Buffer Programming command sequence is initiated by first writing two unlock cycles. This is followed by a third write cycle containing the Write Buffer Load command written at the Sector Address in which programming will occur. At this point, the system writes the number of "**word locations minus 1**" that will be loaded into the page buffer at the Sector Address in which programming will occur. This tells the device how many write buffer addresses will be loaded with data and therefore when to expect the "Program Buffer to Flash" confirm command. The number of locations to program cannot exceed the size of the write buffer or the operation will abort. (NOTE: the size of the write buffer is dependent upon which data are being loaded. Also note that the number loaded = the number of locations to program minus 1. For example, if the system will program 6 address locations, then 05h should be written to the device.)

The system then writes the starting address/data combination. This starting address is the first address/data pair to be programmed, and selects the "write-buffer-page" address. All subsequent address/data pairs **must** fall within the "selected-write-buffer-page".

The "write-buffer-page" is selected by using the addresses $A_{MAX} - A5$ where A_{MAX} is A23 for WS256N.

The "write-buffer-page" addresses **must be the same for all address/data pairs loaded into the write buffer**. (This means Write Buffer Programming **cannot** be performed across multiple "write-buffer-pages". This also means that Write Buffer Programming **cannot** be performed across multiple sectors. If the system attempts to load programming data outside of the selected "write-buffer-page", the operation will ABORT.)

After writing the Starting Address/Data pair, the system then writes the remaining address/data pairs into the write buffer. Write buffer locations may be loaded in any order.

Note that if a Write Buffer address location is loaded multiple times, the "address/data pair" counter **will be decremented for every data load operation**. Also, the **last data loaded** at a location before the "Program Buffer to Flash" confirm command will be programmed into the device. It is the software's responsibility to comprehend ramifications of loading a write-buffer location more than once. The counter decrements **for each data load operation, NOT for each unique write-buffer-address location**.

Once the specified number of write buffer locations have been loaded, the system must then write the "Program Buffer to Flash" command at the Sector Address.

Any other address/data write combinations will abort the Write Buffer Programming operation. The device will then "go busy." The Data Bar polling techniques should be used while monitoring the **last address location loaded into the write buffer**. This eliminates the need to store an address in memory because the system can load the last address location, issue the program confirm command at the last loaded address location, and then data bar poll at that same address. DQ7, DQ6, DQ5, DQ2, and DQ1 should be monitored to determine the device status during Write Buffer Programming.

The write-buffer "embedded" programming operation can be suspended using the standard suspend/resume commands. Upon successful completion of the Write Buffer Programming operation, the device will return to READ mode.

The Write Buffer Programming Sequence is ABORTED under any of the following conditions:

- Load a value that is greater than the page buffer size during the "Number of Locations to Program" step.
- Write to an address in a sector different than the one specified during the "Write-Buffer-Load" command.
- Write an Address/Data pair to a different write-buffer-page than the one selected by the "Starting Address" during the "write buffer data loading" stage of the operation.
- Write data other than the "Confirm Command" after the specified number of "data load" cycles.

The ABORT condition is indicated by DQ1 = 1, DQ7 = DATA# (for the "last address location loaded"), DQ6 = TOGGLE, DQ5 = 0. This indicates that the Write Buffer Programming Operation was ABORTED. A "Write-to-Buffer-Abort reset" command sequence is required when using the Write-Buffer-Programming features in Unlock Bypass mode. Note that the SecSI™ sector, autoselect, and CFI functions are unavailable when a program operation is in progress.

Write buffer programming is allowed in any sequence of memory (or address) locations. These flash devices are capable of handling multiple write buffer programming operations on the same write buffer address range without intervening erases. However, programming the same word address multiple times without intervening erases requires a modified programming method. Please contact your local Spansion™ representative for details.

Use of the write buffer is strongly recommended for programming when multiple words are to be programmed. Write buffer programming is approximately eight times faster than programming one word at a time.

Autoselect Mode

The autoselect mode provides manufacturer and device identification, and sector protection verification, through identifier codes output from the internal register (separate from the memory array) on DQ15–DQ0. This mode is primarily intended for programming equipment to automatically match a device to be programmed with its corresponding programming algorithm. The autoselect codes can also be accessed in-system.

When verifying sector protection, the sector address must appear on the appropriate highest order address bits (see [Table 12](#)). The remaining address bits are don't care. When all necessary bits have been set as required, the programming equipment may then read the corresponding identifier code on DQ15–DQ0. The autoselect codes can also be accessed in-system through the command register. The command sequence is illustrated in the "[Command Definition Summary](#)" sec-

tion. Note that if a Bank Address (BA) on the four uppermost address bits is asserted during the third write cycle of the autoselect command, the host system can read autoselect data from that bank and then immediately read array data from the other bank, without exiting the autoselect mode.

To access the autoselect codes, the host system must issue the autoselect command via the command register, as shown in the "Command Definition Summary" section. Refer to the "Autoselect Command Sequence" section for more information.

Advanced Sector Protection and Unprotection

This advanced security feature provides an additional level of protection to all sectors against inadvertent program or erase operations.

The advanced sector protection feature disables both programming and erase operations in a sector while the advanced sector unprotection feature re-enables both program and erase operations in previously protected sectors. Sector protection/unprotection can be implemented using either or both of the two methods

- Hardware method
- Software method

Persistent/Password Sector Protection is achieved by using the software method while the sector protection with WP# pin is achieved by using the hardware method.

All parts default to operate in the Persistent Sector Protection mode. The customer must then choose if the Persistent or Password Protection method is most desirable. There are two one-time programmable non-volatile bits that define which sector protection method will be used.

- Persistent Mode Lock Bit
- Password Mode Lock Bit

If the customer decides to continue using the Persistent Sector Protection method, they must set the **Persistent Mode Lock Bit**. This will permanently set the part to operate using only Persistent Sector Protection. However, if the customer decides to use the Password Sector Protection method, they must set the **Password Mode Lock Bit**. This will permanently set the part to operate using only Password Sector Protection.

It is important to remember that setting either the **Persistent Mode Lock Bit** or the **Password Mode Lock Bit** permanently selects the protection mode. It is not possible to switch between the two methods once a locking bit has been set. **It is important that one mode is explicitly selected when the device is first programmed, rather than relying on the default mode alone. If both are selected to be set at the same time, the operation will abort.** This is done so that it is not possible for a system program or virus to later set the Password Mode Locking Bit, which would cause an unexpected shift from the default Persistent Sector Protection Mode into the Password Sector Protection Mode.

The device is shipped with all sectors unprotected. Optional Spansion™ programming services enable programming and protecting sectors at the factory prior to shipping the device. Contact your local sales office for more details.

Persistent Mode Lock Bit

A Persistent Mode Lock Bit exists to guarantee that the device remain in software sector protection. Once programmed (set to "0"), the Persistent Mode Lock Bit prevents programming of the Password Mode Lock Bit. This allows protection

from potential hackers locking the device by placing the device in password sector protection mode and then changing the password accordingly.

Password Mode Lock Bit

In order to select the Password Sector Protection scheme, the customer must first program the password. Spansion LLC recommends that the password be somehow correlated to the unique Electronic Serial Number (ESN) of the particular flash device. Each ESN is different for every flash device; therefore each password should be different for every flash device. While programming in the password region, the customer may perform Password Verify operations.

Once the desired password is programmed in, the customer must then set the Password Mode Locking Bit. This operation achieves two objectives:

1. It permanently sets the device to operate using the Password Sector Protection Mode. It is not possible to reverse this function.
2. It also disables *all further commands* to the password region. All program and read operations are ignored.

Both of these objectives are important, and if not carefully considered, may lead to unrecoverable errors. The user must be sure that the Password Sector Protection method is desired when setting the Password Mode Locking Bit. More importantly, the user must be sure that the password is correct when the Password Mode Locking Bit is set. Due to the fact that read operations are disabled, there is no means to verify what the password is after it is set. If the password is lost after setting the Password Mode Lock Bit, there will be no way to clear the PPB Lock Bit.

The Password Mode Lock Bit, once set, prevents reading the 64-bit password on the DQ bus and further password programming. **The Password Mode Lock Bit is not erasable.** Once the Password Mode Lock Bit is programmed, the Persistent Mode Lock Bit is disabled from programming, guaranteeing that no changes to the protection scheme are allowed.

Sector Protection

The device features several levels of sector protection, which can disable both the program and erase operations in certain sectors.

- Persistent Sector Protection: A software enabled command sector protection method that replaces the old 12 V controlled protection method.
- Password Sector Protection: A highly sophisticated software enabled protection method that requires a password before changes to certain sectors or sector groups are permitted
- WP# Hardware Protection: A write protect pin (WP#) can prevent program or erase operations in the outermost sectors. The WP# Hardware Protection feature is always available, independent of the software managed protection method chosen.

Persistent Sector Protection

The Persistent Sector Protection method replaces the old 12 V controlled protection method while at the same time enhancing flexibility by providing three different sector protection states:

- Persistently Locked—A sector is protected and cannot be changed.
- Dynamically Locked—The sector is protected and can be changed by a simple command

- Unlocked—The sector is unprotected and can be changed by a simple command

In order to achieve these states, three types of “bits” namely Persistent Protection Bit (PPB), Dynamic Protection Bit (DYB), and Persistent Protection Bit Lock (PPB Lock) are used to achieve the desired sector protection scheme

Persistent Protection Bit (PPB)

PPB is used to as an advanced security feature to protect individual sectors from being programmed or erased thereby providing additional level of protection. Every sector is assigned a Persistent Protection Bit.

Each PPB is individually programmed through the **PPB Program Command**. However all PPBs are erased in parallel through the **All PPB Erase Command**. Prior to erasing, these bits dont have to be preprogrammed. The Embedded Erase algorithm automatically preprograms and verifies prior to an electrical erase. The system is not required to provide any controls or timings during these operations.

The PPBs retain their state across power cycles because they are Non-Volatile. The PPBs have the same endurance as the flash memory.

Persistent Protection Bit Lock (PPB Lock Bit) in Persistent Sector Protection Mode

PPB Lock Bit is a global volatile bit and provides an additional level of protection to the sectors. When **programmed (set to “0”)**, all the PPBs are locked and hence none of them can be changed. When **erased (cleared to “1”)**, the PPBs are changeable. There is only one PPB Lock Bit in every device. Only a hardware reset or a power-up clears the PPB Lock Bit. It is to be noted that there is no software solution, ie. command sequence to unlock the PPB Lock Bit.

Once all PPBs are set (programmed to “0”) to the desired settings, the PPB Lock Bit may be set (programmed to “0”). The PPB Lock Bit is set by issuing the PPB Lock Bit Set Command. Programming or setting the PPB Lock Bit disables program and erase commands to all the PPBs. In effect, the PPB Lock Bit locks the PPBs into their current state. The only way to clear the PPB Lock Bit is to go through a hardware or powerup reset. System boot code can determine if any changes to the PPB are needed e.g. to allow new system code to be downloaded. If no changes are needed then the boot code can disable the PPB Lock Bit to prevent any further changes to the PPBs during system operation.

Dynamic Protection Bit (DYB)

DYB is another security feature used to protect individual sectors from being programmed or erased inadvertently. It is a volatile protection bit and is assigned to each sector. Each DYB can be individually modified through the DYB Set Command or the DYB Clear Command.

The Protection Status for a particular sector is determined by the status of the PPB and the DYB relative to that sector. For the sectors that have the PPBs cleared (erased to “1”), the DYBs control whether or not the sector is protected or unprotected. By issuing the DYB Set or Clear command sequences, the DYBs will be set (programmed to “0”) or cleared (erased to “1”), thus placing each sector in the protected or unprotected state respectively. These states are the so-called **Dynamic Locked or Unlocked** states due to the fact that they can switch back and forth between the protected and unprotected states. This feature allows software to easily protect sectors against inadvertent changes yet does not prevent the easy removal of protection when changes are needed. The DYBs maybe set (programmed to “0”) or cleared (erased to “1”) as often as needed.

When the parts are first shipped, the PPBs are cleared (erased to "1") and upon power up or reset, the DYBs are set or cleared depending upon the ordering option chosen. If the option to clear the DYBs after power up is chosen, (erased to "1"), then the sectors may be modified depending upon the PPB state of that sector. (See Table 5) If the option to set the DYBs after power up is chosen (programmed to "0"), then the sectors would be in the protected state. The PPB Lock Bit defaults to the cleared state (erased to "1") after power up and the PPBs retain their previous state as they are non-volatile. The default DYB state is cleared (erased to "1") with the sectors in the unprotected state.

It is possible to have sectors that have been persistently locked, and sectors that are left in the dynamic state. The sectors in the dynamic state are all unprotected. If there is a need to protect some of them, a simple DYB Set command sequence is all that is necessary. The DYB Set or Clear command for the dynamic sectors signify protected or unprotected state of the sectors respectively. However, if there is a need to change the status of the persistently locked sectors, a few more steps are required. First, the PPB Lock Bit must be cleared by either putting the device through a power-cycle, or hardware reset. The PPBs can then be changed to reflect the desired settings. Setting the PPB Lock Bit once again will lock the PPBs, and the device operates normally again.

Note: to achieve the best protection, it's recommended to execute the PPB Lock Bit Set command early in the boot code, and protect the boot code by holding $WP\# = V_{IL}$. Note that the PPB and DYB bits have the same function when $ACC = V_{HH}$ as they do when $ACC = V_{IH}$.

Table 5. Sector Protection Schemes

DYB	PPB	PPB Lock	Sector State
1	1	1	Sector Unprotected
0	1	1	Sector Protected through DYB
1	0	1	Sector Protected through PPB
0	0	1	Sector Protected through PPB and DYB
1	1	0	Sector Unprotected
0	1	0	Sector Protected through DYB
1	0	0	Sector Protected through PPB
0	0	0	Sector Protected through PPB and DYB

Table 5 contains all possible combinations of the DYB, PPB, and PPB Lock relating to the status of the sector.

In summary, if the PPB is set (programmed to "0"), and the PPB Lock is set (programmed to "0"), the sector is protected and the protection can not be removed until the next power cycle clears (erase to "1") the PPB Lock Bit. Once the PPB Lock Bit is cleared (erased to "1"), the sector can be persistently locked or unlocked. Likewise, if both PPB Lock Bit or PPB is cleared (erased to "1") the sector can then be dynamically locked or unlocked. The DYB then controls whether or not the sector is protected or unprotected.

If the user attempts to program or erase a protected sector, the device ignores the command and returns to read mode. A program or erase command to a pro-

ected sector enables status polling and returns to read mode without having modified the contents of the protected sector.

The programming of the DYB, PPB, and PPB Lock for a given sector can be verified by writing individual status read commands DYB Status, PPB Status, and PPB Lock Status to the device.

Password Sector Protection

The Password Sector Protection Mode method allows an even higher level of security than the Persistent Sector Protection Mode. There are two main differences between the Persistent Sector Protection Mode and the Password Sector Protection Mode:

- When the device is first powered up, or comes out of a reset cycle, the **PPB Lock Bit is set to the locked state**, rather than cleared to the unlocked state.
- The only means to clear the PPB Lock Bit is by writing a unique **64-bit Password** to the device.

The Password Sector Protection method is otherwise identical to the Persistent Sector Protection method.

A 64-bit password is the only additional tool utilized in this method.

The password is stored in a **one-time programmable (OTP)** region of the flash memory. Once the Password Mode Lock Bit is set, the password is permanently set with no means to read, program, or erase it. The password is used to clear the PPB Lock Bit. The Password Unlock command must be written to the flash, along with a password. The flash device internally compares the given password with the pre-programmed password. If they match, the PPB Lock Bit is cleared, and the PPBs can be altered. If they do not match, the flash device does nothing. There is a built-in 1 μ s delay for each "password check." This delay is intended to thwart any efforts to run a program that tries all possible combinations in order to crack the password.

64-bit Password

The 64-bit Password is located in its own memory space and is accessible through the use of the Password Program and Verify commands. The password function works in conjunction with the Password Mode Locking Bit, which when set, prevents the Password Verify command from reading the contents of the password on the pins of the device.

Persistent Protection Bit Lock (PPB Lock Bit) in Password Sector Protection Mode

The Persistent Protection Bit Lock (PPB Lock Bit) is a volatile bit that reflects the state of the Password Mode Lock Bit after power-up reset. If the Password Mode Lock Bit is also set, after a hardware reset (RESET# asserted) or a power-up reset, the **ONLY** means for clearing the PPB Lock Bit in Password Protection Mode is to issue the Password Unlock command. Successful execution of the Password Unlock command to enter the entire password clears the PPB Lock Bit, allowing for sector PPBs modifications. Asserting RESET# or taking the device through a power-on reset, resets the PPB Lock Bit to a "1".

If the Password Mode Lock Bit is not set (device is operating in the default Persistent Protection Mode). The Password Unlock command is ignored in Persistent Sector Protection Mode.

Lock Register

The Lock Register consists of 4 bits. The Customer SecSi Sector Protection Bit is DQ0, Persistent Protection Mode Lock Bit is DQ1, Password Protection Mode Lock Bit is DQ2, and Persistent Sector Protection OTP Bit is DQ3. Each of these bits are non-volatile. DQ15-DQ4 are reserved and will be 1's.

Table 6. Lock Register

DQ15-3	DQ2	DQ1	DQ0
1's	Password Protection Mode Lock Bit	Persistent Protection Mode Lock Bit	Customer SecSi Sector Protection Bit

Hardware Data Protection Mode

The device offers two types of data protection at the sector level:

- When WP# is at V_{IL} , the four outermost sectors are locked (device specific).
- When ACC is at V_{IL} , all sectors are locked.

The write protect pin (WP#) adds a final level of hardware program and erase protection to the outermost boot sectors. The outermost boot sectors are the sectors containing both the lower and upper set of outermost sectors in a dual-boot-configured device. **When this pin is low it is not possible to change the contents of these outermost sectors.** These sectors generally hold system boot code. So, the WP# pin can prevent any changes to the boot code that could override the choices made while setting up sector protection during system initialization.

The following hardware data protection measures prevent accidental erasure or programming, which might otherwise be caused by spurious system level signals during V_{CC} power-up and power-down transitions, or from system noise.

Write Protect (WP#)

The Write Protect feature provides a hardware method of protecting the four outermost sectors. This function is provided by the WP# pin and overrides the previously discussed Sector Protection/Unprotection method.

If the system asserts V_{IL} on the WP# pin, the device disables program and erase functions in the "outermost" boot sectors. The outermost boot sectors are the sectors containing both the lower and upper set of sectors in a dual-boot-configured device.

If the system asserts V_{IH} on the WP# pin, the device reverts to whether the boot sectors were last set to be protected or unprotected. That is, sector protection or unprotection for these sectors depends on whether they were last protected or unprotected.

Note that the WP# pin must not be left floating or unconnected; inconsistent behavior of the device may result. The WP# pin must be held stable during a command sequence execution.

Low V_{CC} Write Inhibit

When V_{CC} is less than V_{LKO} , the device does not accept any write cycles. This protects data during V_{CC} power-up and power-down. The command register and all internal program/erase circuits are disabled, and the device resets to reading array data. Subsequent writes are ignored until V_{CC} is greater than V_{LKO} . The system must provide the proper signals to the control inputs to prevent unintentional writes when V_{CC} is greater than V_{LKO} .

Write Pulse “Glitch” Protection

Noise pulses of less than 3 ns (typical) on OE#, CE# or WE# do not initiate a write cycle.

Logical Inhibit

Write cycles are inhibited by holding any one of OE# = V_{IL} , CE# = V_{IH} or WE# = V_{IH} . To initiate a write cycle, CE# and WE# must be a logical zero while OE# is a logical one.

Power-Up Write Inhibit

If WE# = CE# = RESET# = V_{IL} and OE# = V_{IH} during power up, the device does not accept commands on the rising edge of WE#. The internal state machine is automatically reset to the read mode on power-up

Standby Mode

When the system is not reading or writing to the device, it can place the device in the standby mode. In this mode, current consumption is greatly reduced, and the outputs are placed in the high impedance state, independent of the OE# input.

The device enters the CMOS standby mode when the CE# and RESET# inputs are both held at $V_{CC} \pm 0.2$ V. The device requires standard access time (t_{CE}) for read access, before it is ready to read data.

If the device is deselected during erasure or programming, the device draws active current until the operation is completed.

I_{CC3} in “DC Characteristics” represents the standby current specification.

Automatic Sleep Mode

The automatic sleep mode minimizes Flash device energy consumption. While in asynchronous mode, the device automatically enables this mode when addresses remain stable for $t_{ACC} + 20$ ns. The automatic sleep mode is independent of the CE#, WE#, and OE# control signals. Standard address access timings provide new data when addresses are changed. While in sleep mode, output data is latched and always available to the system. While in synchronous mode, the automatic sleep mode is disabled. Note that a new burst operation is required to provide new data.

I_{CC6} in “DC Characteristics” represents the automatic sleep mode current specification.

RESET#: Hardware Reset Input

The RESET# input provides a hardware method of resetting the device to reading array data. When RESET# is driven low for at least a period of t_{RP} , the device immediately terminates any operation in progress, tristates all outputs, resets the configuration register, and ignores all read/write commands for the duration of the RESET# pulse. The device also resets the internal state machine to reading array data. The operation that was interrupted should be reinitiated once the device is ready to accept another command sequence, to ensure data integrity.

Current is reduced for the duration of the RESET# pulse. When RESET# is held at $V_{SS} \pm 0.2$ V, the device draws CMOS standby current (I_{CC4}). If RESET# is held at V_{IL} but not within $V_{SS} \pm 0.2$ V, the standby current will be greater.

RESET# may be tied to the system reset circuitry. A system reset would thus also reset the Flash memory, enabling the system to read the boot-up firmware from the Flash memory.

If RESET# is asserted during a program or erase operation, the device requires a time of $t_{RP}+t_{RP}$ (during Embedded Algorithms) before the device is ready to read data again. If RESET# is asserted when a program or erase operation is not executing, the reset operation is completed within a time of t_{RP} (not during Embedded Algorithms). The system can read data t_{RH} after RESET# returns to V_{IH} .

Refer to the "[Hardware Reset \(RESET#\)](#)" section for RESET# parameters and to [Figure 20](#) for the timing diagram.

Output Disable Mode

When the OE# input is at V_{IH} , output from the device is disabled. The outputs are placed in the high impedance state.

SecSi™ (Secured Silicon) Sector Flash Memory Region

The SecSi (Secured Silicon) Sector feature provides an extra Flash memory region that enables permanent part identification through an Electronic Serial Number (ESN). The SecSi Sector is 256 words in length. All reads outside of the 256 word address range will return non-valid data. The Factory Indicator Bit (DQ7) is used to indicate whether or not the Factory SecSi Sector is locked when shipped from the factory. The Customer Indicator Bit (DQ6) is used to indicate whether or not the Customer SecSi Sector is locked when shipped from the factory. The Factory SecSi bits are permanently set at the factory and cannot be changed, which prevents cloning of a factory locked part. This ensures the security of the ESN and customer code once the product is shipped to the field.

The Factory portion of the SecSi Sector is locked when shipped and the Customer SecSi Sector that is either locked or is lockable. The Factory SecSi Sector is always protected when shipped from the factory, and has the Factory Indicator Bit (DQ7) permanently set to a "1". The Customer SecSi Sector is typically shipped unprotected, allowing customers to utilize that sector in any manner they choose. The Customer Indicator Bit set to "0." Once the Customer SecSi Sector area is protected, the Customer Indicator Bit will be permanently set to "1."

The system accesses the SecSi Sector through a command sequence (see the "[Enter SecSi™ Sector/Exit SecSi Sector Command Sequence](#)" section). After the system has written the Enter SecSi Sector command sequence, it may read the SecSi Sector by using the addresses normally occupied by the memory array. This mode of operation continues until the system issues the Exit SecSi Sector command sequence, or until power is removed from the device. While SecSi Sector access is enabled, Memory Array read access, program operations, and erase operations to all sectors other than SA0 are also available. On power-up, or following a hardware reset, the device reverts to sending commands to the normal address space.

Factory Locked: Factor SecSi Sector Programmed and Protected At the Factory

In a factory sector locked device, the Factory SecSi Sector is protected when the device is shipped from the factory. The Factory SecSi Sector cannot be modified in any way. The device is pre programmed with both a random number and a secure ESN. The Factory SecSi Sector is located at addresses 000000h-00007Fh.

The device is available pre programmed with one of the following:

- A random, secure ESN only within the Factor SecSi Sector
- Customer code within the Customer SecSi Sector through the Spansion™ programming service
- Both a random, secure ESN and customer code through the Spansion™ programming service.

Table 7. SecSi™ Sector Addresses

Sector	Sector Size	Address Range
Customer	128 words	000080h-0000FFh
Factory	128 words	000000h-00007Fh

Customers may opt to have their code programmed by Spansion through the Spansion™ programming services. Spansion programs the customer’s code, with or without the random ESN. The devices are then shipped from Spansion’s factory with the Factory SecSi Sector and Customer SecSi Sector permanently locked. Contact your local representative for details on using Spansion™ programming services.

Customer SecSi Sector

If the security feature is not required, the Customer SecSi Sector can be treated as an additional Flash memory space. The Customer SecSi Sector can be read any number of times, but can be programmed and locked only once. Note that the accelerated programming (ACC) and unlock bypass functions are not available when programming the Customer SecSi Sector, but reading in Banks 1 through 15 is available. The Customer SecSi Sector is located at addresses 000080h–0000FFh.

The Customer SecSi Sector area can be protected by writing the SecSi Sector Protection Bit Lock command sequence.

Once the Customer SecSi Sector is locked and verified, the system must write the Exit SecSi Sector Region command sequence to return to reading and writing the remainder of the array.

The Customer SecSi Sector lock must be used with caution since, once locked, there is no procedure available for unlocking the Customer SecSi Sector area and none of the bits in the Customer SecSi Sector memory space can be modified in any way.

SecSi Sector Protection Bit

The Customer SecSi Sector Protection Bit prevents programming of the Customer SecSi Sector memory area. Once set, the Customer SecSi Sector memory area contents are non-modifiable.

Common Flash Memory Interface (CFI)

The Common Flash Interface (CFI) specification outlines device and host system software interrogation handshake, which allows specific vendor-specified software algorithms to be used for entire families of devices. Software support can then be device-independent, JEDEC ID-independent, and forward- and backward-compatible for the specified flash device families. Flash vendors can standardize their existing interfaces for long-term compatibility.

This device enters the CFI Query mode when the system writes the CFI Query command, 98h, to address (BA)555h any time the device is ready to read array data. The system can read CFI information at the addresses given in [Table 8](#)

through [Table 11](#) within that bank. All reads outside of the CFI address range, within the bank, will return non-valid data. Reads from other banks are allowed, writes are not. To terminate reading CFI data, the system must write the reset command.

The system can also write the CFI query command when the device is in the autoselect mode. The device enters the CFI query mode, and the system can read CFI data at the addresses given in [Table 8](#) through [Table 11](#). The system must write the reset command to return the device to the autoselect mode.

For further information, please refer to the CFI Specification and CFI Publication 100. Please contact your sales office for copies of these documents.

Table 8. CFI Query Identification String

Addresses	Data	Description
10h 11h 12h	0051h 0052h 0059h	Query Unique ASCII string "QRY"
13h 14h	0002h 0000h	Primary OEM Command Set
15h 16h	0040h 0000h	Address for Primary Extended Table
17h 18h	0000h 0000h	Alternate OEM Command Set (00h = none exists)
19h 1Ah	0000h 0000h	Address for Alternate OEM Extended Table (00h = none exists)

Table 9. System Interface String

Addresses	Data	Description
1Bh	0017h	V _{CC} Min. (write/erase) DQ7-DQ4: volt, DQ3-DQ0: 100 millivolt
1Ch	0019h	V _{CC} Max. (write/erase) DQ7-DQ4: volt, DQ3-DQ0: 100 millivolt
1Dh	0000h	V _{pp} Min. voltage (00h = no V _{pp} pin present)
1Eh	0000h	V _{pp} Max. voltage (00h = no V _{pp} pin present)
1Fh	0005h	Typical timeout per single byte/word write 2 ⁿ μs (Note)
20h	0009h	Typical timeout for Min. size buffer write 2 ⁿ μs (00h = not supported) (Note)
21h	0008h	Typical timeout per individual block erase 2 ⁿ ms
22h	0000h	Typical timeout for full chip erase 2 ⁿ ms (00h = not supported)
23h	0003h	Max. timeout for byte/word write 2 ⁿ times typical (Note)
24h	0001h	Max. timeout for buffer write 2 ⁿ times typical (Note)
25h	0003h	Max. timeout per individual block erase 2 ⁿ times typical
26h	0000h	Max. timeout for full chip erase 2 ⁿ times typical (00h = not supported)

Not supported due to page programming requirement

Table I0. Device Geometry Definition

Addresses	Data	Description
27h	0019h (WS256N)	Device Size = 2 ^N byte
28h 29h	0001h 0000h	Flash Device Interface description (refer to CFI publication 100)
2Ah 2Bh	0005h 0000h	Max. number of bytes in multi-byte write = 2 ^N (00h = not supported)
2Ch	0003h	Number of Erase Block Regions within device
2Dh 2Eh 2Fh 30h	0003h 0000h 0080h 0000h	Erase Block Region 1 Information (refer to the CFI specification or CFI publication 100)
31h	00FDh (WS256N)	Erase Block Region 2 Information
32h	0000h	
33h	0000h	
34h	0002h	
35h 36h 37h 38h	0003h 0000h 0080h 0000h	Erase Block Region 3 Information
39h 3Ah 3Bh 3Ch	0000h 0000h 0000h 0000h	Erase Block Region 4 Information

Table II. Primary Vendor-Specific Extended Query

Addresses	Data	Description
40h 41h 42h	0050h 0052h 0049h	Query-unique ASCII string "PRI"
43h	0031h	Major version number, ASCII
44h	0034h	Minor version number, ASCII
45h	0010h	Address Sensitive Unlock (Bits 1-0) 0 = Required, 1 = Not Required Silicon Technology (Bits 5-2) 0011 = 0.13 μm
46h	0002h	Erase Suspend 0 = Not Supported, 1 = To Read Only, 2 = To Read & Write
47h	0001h	Sector Protect 0 = Not Supported, X = Number of sectors in per group
48h	0000h	Sector Temporary Unprotect 00 = Not Supported, 01 = Supported
49h	0008h	Sector Protect/Unprotect scheme 08 = Advanced Sector Protection
4Ah	00DFh (WS256N)	Simultaneous Operation Number of Sectors in all banks except boot bank

Table II. Primary Vendor-Specific Extended Query (Continued)

Addresses	Data	Description
4Bh	0001h	Burst Mode Type 00 = Not Supported, 01 = Supported
4Ch	0000h	Page Mode Type 00 = Not Supported, 01 = 4 Word Page, 02 = 8 Word Page, 04 = 16 Word Page
4Dh	0085h	ACC (Acceleration) Supply Minimum 00h = Not Supported, DQ7-DQ4: Volt, DQ3-DQ0: 100 mV
4Eh	0095h	ACC (Acceleration) Supply Maximum 00h = Not Supported, DQ7-DQ4: Volt, DQ3-DQ0: 100 mV
4Fh	0001h	Top/Bottom Boot Sector Flag 0001h = Dual Boot Device
50h	0001h	Program Suspend. 00h = not supported
51h	0001h	Unlock Bypass 00 = Not Supported, 01=Supported
52h	0007h	SecSi Sector (Customer OTP Area) Size 2 ⁿ bytes
53h	0014h	Hardware Reset Low Time-out during an embedded algorithm to read mode Maximum 2 ⁿ ns
54h	0014h	Hardware Reset Low Time-out not during an embedded algorithm to read mode Maximum 2 ⁿ ns
55h	0005h	Erase Suspend Time-out Maximum 2 ⁿ ns
56h	0005h	Program Suspend Time-out Maximum 2 ⁿ ns
57h	0010h	Bank Organization: X = Number of banks
58h	0013h (WS256N)	Bank 0 Region Information. X = Number of sectors in bank
59h	0010h (WS256N)	Bank 1 Region Information. X = Number of sectors in bank
5Ah	0010h (WS256N)	Bank 2 Region Information. X = Number of sectors in bank
5Bh	0010h (WS256N)	Bank 3 Region Information. X = Number of sectors in bank
5Ch	0010h (WS256N)	Bank 4 Region Information. X = Number of sectors in bank
5Dh	0010h (WS256N)	Bank 5 Region Information. X = Number of sectors in bank
5Eh	0010h (WS256N)	Bank 6 Region Information. X = Number of sectors in bank
5Fh	0010h (WS256N)	Bank 7 Region Information. X = Number of sectors in bank
60h	0010h (WS256N)	Bank 8 Region Information. X = Number of sectors in bank
61h	0010h (WS256N)	Bank 9 Region Information. X = Number of sectors in bank
62h	0010h (WS256N)	Bank 10 Region Information. X = Number of sectors in bank
63h	0010h (WS256N)	Bank 11 Region Information. X = Number of sectors in bank
64h	0010h (WS256N)	Bank 12 Region Information. X = Number of sectors in bank
65h	0010h (WS256N)	Bank 13 Region Information. X = Number of sectors in bank
66h	0010h (WS256N)	Bank 14 Region Information. X = Number of sectors in bank
67h	0013h (WS256N)	Bank 15 Region Information. X = Number of sectors in bank

Table 12. Sector Address / Memory Address Map for the WS256N

Bank	Sector	Sector Size	A23-A14	(x16) Address Range
Bank 0	SA0	16 Kwords	000000000	000000h-003FFFh
	SA1	16 Kwords	000000001	004000h-007FFFh
	SA2	16 Kwords	000000010	008000h-00BFFFh
	SA3	16 Kwords	000000011	00C000h-00FFFFh
	SA4	64 Kwords	00000001XX	010000h-01FFFFh
	SA5	64 Kwords	00000010XX	020000h-02FFFFh
	SA6	64 Kwords	00000011XX	030000h-03FFFFh
	SA7	64 Kwords	00000100XX	040000h-04FFFFh
	SA8	64 Kwords	00000101XX	050000h-05FFFFh
	SA9	64 Kwords	00000110XX	060000h-06FFFFh
	SA10	64 Kwords	00000111XX	070000h-07FFFFh
	SA11	64 Kwords	00001000XX	080000h-08FFFFh
	SA12	64 Kwords	00001001XX	090000h-09FFFFh
	SA13	64 Kwords	00001010XX	0A0000h-0AFFFFh
	SA14	64 Kwords	00001011XX	0B0000h-0BFFFFh
	SA15	64 Kwords	00001100XX	0C0000h-0CFFFFh
	SA16	64 Kwords	00001101XX	0D0000h-0DFFFFh
	SA17	64 Kwords	00001110XX	0E0000h-0EFFFFh
SA18	64 Kwords	00001111XX	0F0000h-0FFFFFh	
Bank 1	SA19	64 Kwords	00010000XX	100000h-10FFFFh
	SA20	64 Kwords	00010001XX	110000h-11FFFFh
	SA21	64 Kwords	00010010XX	120000h-12FFFFh
	SA22	64 Kwords	00010011XX	130000h-13FFFFh
	SA23	64 Kwords	00010100XX	140000h-14FFFFh
	SA24	64 Kwords	00010101XX	150000h-15FFFFh
	SA25	64 Kwords	00010110XX	160000h-16FFFFh
	SA26	64 Kwords	00010111XX	170000h-17FFFFh
	SA27	64 Kwords	00011000XX	180000h-18FFFFh
	SA28	64 Kwords	00011001XX	190000h-19FFFFh
	SA29	64 Kwords	00011010XX	1A0000h-1AFFFFh
	SA30	64 Kwords	00011011XX	1B0000h-1BFFFFh
	SA31	64 Kwords	00011100XX	1C0000h-1CFFFFh
	SA32	64 Kwords	00011101XX	1D0000h-1DFFFFh
	SA33	64 Kwords	00011110XX	1E0000h-1EFFFFh
	SA34	64 Kwords	00011111XX	1F0000h-1FFFFFh

Table 12. Sector Address / Memory Address Map for the WS256N (Continued)

Bank	Sector	Sector Size	A23-A14	(x16) Address Range
Bank 2	SA35	64 Kwords	00100000XX	200000h-20FFFFh
	SA36	64 Kwords	00100001XX	210000h-21FFFFh
	SA37	64 Kwords	00100010XX	220000h-22FFFFh
	SA38	64 Kwords	00100011XX	230000h-23FFFFh
	SA39	64 Kwords	00100100XX	240000h-24FFFFh
	SA40	64 Kwords	00100101XX	250000h-25FFFFh
	SA41	64 Kwords	00100110XX	260000h-26FFFFh
	SA42	64 Kwords	00100111XX	270000h-27FFFFh
	SA43	64 Kwords	00101000XX	280000h-28FFFFh
	SA44	64 Kwords	00101001XX	290000h-29FFFFh
	SA45	64 Kwords	00101010XX	2A0000h-2AFFFFh
	SA46	64 Kwords	00101011XX	2B0000h-2BFFFFh
	SA47	64 Kwords	00101100XX	2C0000h-2CFFFFh
	SA48	64 Kwords	00101101XX	2D0000h-2DFFFFh
	SA49	64 Kwords	00101110XX	2E0000h-2EFFFFh
	SA50	64 Kwords	00101111XX	2F0000h-2FFFFFh
Bank 3	SA51	64 Kwords	00110000XX	300000h-30FFFFh
	SA52	64 Kwords	00110001XX	310000h-31FFFFh
	SA53	64 Kwords	00110010XX	320000h-32FFFFh
	SA54	64 Kwords	00110011XX	330000h-33FFFFh
	SA55	64 Kwords	00110100XX	340000h-34FFFFh
	SA56	64 Kwords	00110101XX	350000h-35FFFFh
	SA57	64 Kwords	00110110XX	360000h-36FFFFh
	SA58	64 Kwords	00110111XX	370000h-37FFFFh
	SA59	64 Kwords	00111000XX	380000h-38FFFFh
	SA60	64 Kwords	00111001XX	390000h-39FFFFh
	SA61	64 Kwords	00111010XX	3A0000h-3AFFFFh
	SA62	64 Kwords	00111011XX	3B0000h-3BFFFFh
	SA63	64 Kwords	00111100XX	3C0000h-3CFFFFh
	SA64	64 Kwords	00111101XX	3D0000h-3DFFFFh
	SA65	64 Kwords	00111110XX	3E0000h-3EFFFFh
	SA66	64 Kwords	00111111XX	3F0000h-3FFFFFh

Table 12. Sector Address / Memory Address Map for the WS256N (Continued)

Bank	Sector	Sector Size	A23-A14	(x16) Address Range
Bank 4	SA67	64 Kwords	01000000XX	400000h-40FFFFh
	SA68	64 Kwords	01000001XX	410000h-41FFFFh
	SA69	64 Kwords	01000010XX	420000h-42FFFFh
	SA70	64 Kwords	01000011XX	430000h-43FFFFh
	SA71	64 Kwords	01000100XX	440000h-44FFFFh
	SA72	64 Kwords	01000101XX	450000h-45FFFFh
	SA73	64 Kwords	01000110XX	460000h-46FFFFh
	SA74	64 Kwords	01000111XX	470000h-47FFFFh
	SA75	64 Kwords	01001000XX	480000h-48FFFFh
	SA76	64 Kwords	01001001XX	490000h-49FFFFh
	SA77	64 Kwords	01001010XX	4A0000h-4AFFFFh
	SA78	64 Kwords	01001011XX	4B0000h-4BFFFFh
	SA79	64 Kwords	01001100XX	4C0000h-4CFFFFh
	SA80	64 Kwords	01001101XX	4D0000h-4DFFFFh
	SA81	64 Kwords	01001110XX	4E0000h-4EFFFFh
	SA82	64 Kwords	01001111XX	4F0000h-4FFFFFFh
Bank 5	SA83	64 Kwords	01010000XX	500000h-50FFFFh
	SA84	64 Kwords	01010001XX	510000h-51FFFFh
	SA85	64 Kwords	01010010XX	520000h-52FFFFh
	SA86	64 Kwords	01010011XX	530000h-53FFFFh
	SA87	64 Kwords	01010100XX	540000h-54FFFFh
	SA88	64 Kwords	01010101XX	550000h-55FFFFh
	SA89	64 Kwords	01010110XX	560000h-56FFFFh
	SA90	64 Kwords	01010111XX	570000h-57FFFFh
	SA91	64 Kwords	01011000XX	580000h-58FFFFh
	SA92	64 Kwords	01011001XX	590000h-59FFFFh
	SA93	64 Kwords	01011010XX	5A0000h-5AFFFFh
	SA94	64 Kwords	01011011XX	5B0000h-5BFFFFh
	SA95	64 Kwords	01011100XX	5C0000h-5CFFFFh
	SA96	64 Kwords	01011101XX	5D0000h-5DFFFFh
	SA97	64 Kwords	01011110XX	5E0000h-5EFFFFh
	SA98	64 Kwords	01011111XX	5F0000h-5FFFFFFh

Table 12. Sector Address / Memory Address Map for the WS256N (Continued)

Bank	Sector	Sector Size	A23-A14	(x16) Address Range
Bank 6	SA99	64 Kwords	01100000XX	600000h-60FFFFh
	SA100	64 Kwords	01100001XX	610000h-61FFFFh
	SA101	64 Kwords	01100010XX	620000h-62FFFFh
	SA102	64 Kwords	01100011XX	630000h-63FFFFh
	SA103	64 Kwords	01100100XX	640000h-64FFFFh
	SA104	64 Kwords	01100101XX	650000h-65FFFFh
	SA105	64 Kwords	01100110XX	660000h-66FFFFh
	SA106	64 Kwords	01100111XX	670000h-67FFFFh
	SA107	64 Kwords	01101000XX	680000h-68FFFFh
	SA108	64 Kwords	01101001XX	690000h-69FFFFh
	SA109	64 Kwords	01101010XX	6A0000h-6AFFFFh
	SA110	64 Kwords	01101011XX	6B0000h-6BFFFFh
	SA111	64 Kwords	01101100XX	6C0000h-6CFFFFh
	SA112	64 Kwords	01101101XX	6D0000h-6DFFFFh
Bank 7	SA113	64 Kwords	01101110XX	6E0000h-6EFFFFh
	SA114	64 Kwords	01101111XX	6F0000h-6FFFFFh
	SA115	64 Kwords	01110000XX	700000h-70FFFFh
	SA116	64 Kwords	01110001XX	710000h-71FFFFh
	SA117	64 Kwords	01110010XX	720000h-72FFFFh
	SA118	64 Kwords	01110011XX	730000h-73FFFFh
	SA119	64 Kwords	01110100XX	740000h-74FFFFh
	SA120	64 Kwords	01110101XX	750000h-75FFFFh
	SA121	64 Kwords	01110110XX	760000h-76FFFFh
	SA122	64 Kwords	01110111XX	770000h-77FFFFh
	SA123	64 Kwords	01111000XX	780000h-78FFFFh
	SA124	64 Kwords	01111001XX	790000h-79FFFFh
	SA125	64 Kwords	01111010XX	7A0000h-7AFFFFh
	SA126	64 Kwords	01111011XX	7B0000h-7BFFFFh
	SA127	64 Kwords	01111100XX	7C0000h-7CFFFFh
	SA128	64 Kwords	01111101XX	7D0000h-7DFFFFh
	SA129	64 Kwords	01111110XX	7E0000h-7EFFFFh
SA130	64 Kwords	01111111XX	7F0000h-7FFFFFh	

Table 12. Sector Address / Memory Address Map for the WS256N (Continued)

Bank	Sector	Sector Size	A23-A14	(x16) Address Range
Bank 8	SA131	64 Kwords	10000000XX	800000h-80FFFFh
	SA132	64 Kwords	10000001XX	810000h-81FFFFh
	SA133	64 Kwords	10000010XX	820000h-82FFFFh
	SA134	64 Kwords	10000011XX	830000h-83FFFFh
	SA135	64 Kwords	10000100XX	840000h-84FFFFh
	SA136	64 Kwords	10000101XX	850000h-85FFFFh
	SA137	64 Kwords	10000110XX	860000h-86FFFFh
	SA138	64 Kwords	10000111XX	870000h-87FFFFh
	SA139	64 Kwords	10001000XX	880000h-88FFFFh
	SA140	64 Kwords	10001001XX	890000h-89FFFFh
	SA141	64 Kwords	10001010XX	8A0000h-8AFFFFh
	SA142	64 Kwords	10001011XX	8B0000h-8BFFFFh
	SA143	64 Kwords	10001100XX	8C0000h-8CFFFFh
	SA144	64 Kwords	10001101XX	8D0000h-8DFFFFh
	SA145	64 Kwords	10001110XX	8E0000h-8EFFFFh
	SA146	64 Kwords	10001111XX	8F0000h-8FFFFFh
Bank 9	SA147	64 Kwords	10010000XX	900000h-90FFFFh
	SA148	64 Kwords	10010001XX	910000h-91FFFFh
	SA149	64 Kwords	10010010XX	920000h-92FFFFh
	SA150	64 Kwords	10010011XX	930000h-93FFFFh
	SA151	64 Kwords	10010100XX	940000h-94FFFFh
	SA152	64 Kwords	10010101XX	950000h-95FFFFh
	SA153	64 Kwords	10010110XX	960000h-96FFFFh
	SA154	64 Kwords	10010111XX	970000h-97FFFFh
	SA155	64 Kwords	10011000XX	980000h-98FFFFh
	SA156	64 Kwords	10011001XX	990000h-99FFFFh
	SA157	64 Kwords	10011010XX	9A0000h-9AFFFFh
	SA158	64 Kwords	10011011XX	9B0000h-9BFFFFh
	SA159	64 Kwords	10011100XX	9C0000h-9CFFFFh
	SA160	64 Kwords	10011101XX	9D0000h-9DFFFFh
	SA161	64 Kwords	10011110XX	9E0000h-9EFFFFh
	SA162	64 Kwords	10011111XX	9F0000h-9FFFFFh

Table 12. Sector Address / Memory Address Map for the WS256N (Continued)

Bank	Sector	Sector Size	A23-A14	(x16) Address Range
Bank 10	SA163	64 Kwords	10100000XX	A00000h-A0FFFFh
	SA164	64 Kwords	10100001XX	A10000h-A1FFFFh
	SA165	64 Kwords	10100010XX	A20000h-A2FFFFh
	SA166	64 Kwords	10100011XX	A30000h-A3FFFFh
	SA167	64 Kwords	10100100XX	A40000h-A4FFFFh
	SA168	64 Kwords	10100101XX	A50000h-A5FFFFh
	SA169	64 Kwords	10100110XX	A60000h-A6FFFFh
	SA170	64 Kwords	10100111XX	A70000h-A7FFFFh
	SA171	64 Kwords	10101000XX	A80000h-A8FFFFh
	SA172	64 Kwords	10101001XX	A90000h-A9FFFFh
	SA173	64 Kwords	10101010XX	AA0000h-AAFFFFh
	SA174	64 Kwords	10101011XX	AB0000h-ABFFFFh
	SA175	64 Kwords	10101100XX	AC0000h-ACFFFFh
	SA176	64 Kwords	10101101XX	AD0000h-ADFFFFh
	SA177	64 Kwords	10101110XX	AE0000h-AEFFFFh
	SA178	64 Kwords	10101111XX	AF0000h-AFFFFFFh
Bank 11	SA179	64 Kwords	10110000XX	B00000h-B0FFFFh
	SA180	64 Kwords	10110001XX	B10000h-B1FFFFh
	SA181	64 Kwords	10110010XX	B20000h-B2FFFFh
	SA182	64 Kwords	10110011XX	B30000h-B3FFFFh
	SA183	64 Kwords	10110100XX	B40000h-B4FFFFh
	SA184	64 Kwords	10110101XX	B50000h-B5FFFFh
	SA185	64 Kwords	10110110XX	B60000h-B6FFFFh
	SA186	64 Kwords	10110111XX	B70000h-B7FFFFh
	SA187	64 Kwords	10111000XX	B80000h-B8FFFFh
	SA188	64 Kwords	10111001XX	B90000h-B9FFFFh
	SA189	64 Kwords	10111010XX	BA0000h-BAFFFFh
	SA190	64 Kwords	10111011XX	BB0000h-BBFFFFh
	SA191	64 Kwords	10111100XX	BC0000h-BCFFFFh
	SA192	64 Kwords	10111101XX	BD0000h-BDFFFFh
	SA193	64 Kwords	10111110XX	BE0000h-BEFFFFh
	SA194	64 Kwords	10111111XX	BF0000h-BFFFFFFh

Table 12. Sector Address / Memory Address Map for the WS256N (Continued)

Bank	Sector	Sector Size	A23-A14	(x16) Address Range
Bank 12	SA195	64 Kwords	11000000XX	C0000h-C0FFFFh
	SA196	64 Kwords	11000001XX	C1000h-C1FFFFh
	SA197	64 Kwords	11000010XX	C2000h-C2FFFFh
	SA198	64 Kwords	11000011XX	C3000h-C3FFFFh
	SA199	64 Kwords	11000100XX	C4000h-C4FFFFh
	SA200	64 Kwords	11000101XX	C5000h-C5FFFFh
	SA201	64 Kwords	11000110XX	C6000h-C6FFFFh
	SA202	64 Kwords	11000111XX	C7000h-C7FFFFh
	SA203	64 Kwords	11001000XX	C8000h-C8FFFFh
	SA204	64 Kwords	11001001XX	C9000h-C9FFFFh
	SA205	64 Kwords	11001010XX	CA000h-CAFFFFh
	SA206	64 Kwords	11001011XX	CB000h-CBFFFFh
	SA207	64 Kwords	11001100XX	CC000h-CCFFFFh
	SA208	64 Kwords	11001101XX	CD000h-CDFFFFh
	SA209	64 Kwords	11001110XX	CE000h-CEFFFFh
	SA210	64 Kwords	11001111XX	CF000h-CFFFFFh
Bank 13	SA211	64 Kwords	11010000XX	D0000h-D0FFFFh
	SA212	64 Kwords	11010001XX	D1000h-D1FFFFh
	SA213	64 Kwords	11010010XX	D2000h-D2FFFFh
	SA214	64 Kwords	11010011XX	D3000h-D3FFFFh
	SA215	64 Kwords	11010100XX	D4000h-D4FFFFh
	SA216	64 Kwords	11010101XX	D5000h-D5FFFFh
	SA217	64 Kwords	11010110XX	D6000h-D6FFFFh
	SA218	64 Kwords	11010111XX	D7000h-D7FFFFh
	SA219	64 Kwords	11011000XX	D8000h-D8FFFFh
	SA220	64 Kwords	11011001XX	D9000h-D9FFFFh
	SA221	64 Kwords	11011010XX	DA000h-DAFFFFh
	SA222	64 Kwords	11011011XX	DB000h-DBFFFFh
	SA223	64 Kwords	11011100XX	DC000h-DCFFFFh
	SA224	64 Kwords	11011101XX	DD000h-DDFFFFh
	SA225	64 Kwords	11011110XX	DE000h-DEFFFFh
	SA226	64 Kwords	11011111XX	DF000h-DFFFFFh

Table 12. Sector Address / Memory Address Map for the WS256N (Continued)

Bank	Sector	Sector Size	A23-A14	(x16) Address Range
Bank 14	SA227	64 Kwords	11100000XX	E0000h-E0FFFFh
	SA228	64 Kwords	11100001XX	E10000h-E1FFFFh
	SA229	64 Kwords	11100010XX	E20000h-E2FFFFh
	SA230	64 Kwords	11100011XX	E30000h-E3FFFFh
	SA231	64 Kwords	11100100XX	E40000h-E4FFFFh
	SA232	64 Kwords	11100101XX	E50000h-E5FFFFh
	SA233	64 Kwords	11100110XX	E60000h-E6FFFFh
	SA234	64 Kwords	11100111XX	E70000h-E7FFFFh
	SA235	64 Kwords	11101000XX	E80000h-E8FFFFh
	SA236	64 Kwords	11101001XX	E90000h-E9FFFFh
	SA237	64 Kwords	11101010XX	EA0000h-EAFFFFh
	SA238	64 Kwords	11101011XX	EB0000h-EBFFFFh
	SA239	64 Kwords	11101100XX	EC0000h-ECFFFFh
	SA240	64 Kwords	11101101XX	ED0000h-EDFFFFh
	SA241	64 Kwords	11101110XX	EE0000h-EEFFFFh
	SA242	64 Kwords	11101111XX	EF0000h-EFFFFFFh
Bank 15	SA243	64 Kwords	11110000XX	F0000h-F0FFFFh
	SA244	64 Kwords	11110001XX	F10000h-F1FFFFh
	SA245	64 Kwords	11110010XX	F20000h-F2FFFFh
	SA246	64 Kwords	11110011XX	F30000h-F3FFFFh
	SA247	64 Kwords	11110100XX	F40000h-F4FFFFh
	SA248	64 Kwords	11110101XX	F50000h-F5FFFFh
	SA249	64 Kwords	11110110XX	F60000h-F6FFFFh
	SA250	64 Kwords	11110111XX	F70000h-F7FFFFh
	SA251	64 Kwords	11111000XX	F80000h-F8FFFFh
	SA252	64 Kwords	11111001XX	F90000h-F9FFFFh
	SA253	64 Kwords	11111010XX	FA0000h-FAFFFFh
	SA254	64 Kwords	11111011XX	FB0000h-FBFFFFh
	SA255	64 Kwords	11111100XX	FC0000h-FCFFFFh
	SA256	64 Kwords	11111101XX	FD0000h-FDFFFFh
	SA257	64 Kwords	11111110XX	FE0000h-FEFFFFh
	SA258	16 Kwords	1111111100	FF0000h-FF3FFFh
	SA259	16 Kwords	1111111101	FF4000h-FF7FFFh
	SA260	16 Kwords	1111111110	FF8000h-FFBFFFh
	SA261	16 Kwords	1111111111	FFC000h-FFFFFFh

Command Definitions

Writing specific address and data commands or sequences into the command register initiates device operations. The "[Command Definition Summary](#)" section defines the valid register command sequences. Writing incorrect address and data values or writing them in the improper sequence may place the device in an unknown state. The system must write the reset command to return the device to reading array data. Refer to "[AC Characteristics—Synchronous](#)" and "[AC Characteristics—Asynchronous](#)" for timing diagrams.

Reading Array Data

The device is automatically set to reading asynchronous array data after device power-up. No commands are required to retrieve data in asynchronous mode. Each bank is ready to read array data after completing an Embedded Program or Embedded Erase algorithm.

After the device accepts an Erase Suspend command, the corresponding bank enters the erase-suspend-read mode, after which the system can read data from any non-erase-suspended sector within the same bank. After completing a programming operation in the Erase Suspend mode, the system may once again read array data from any non-erase-suspended sector within the same bank. See the "[Erase Suspend/Erase Resume Commands](#)" section for more information.

After the device accepts a Program Suspend command, the corresponding bank enters the program-suspend-read mode, after which the system can read data from any non-program-suspended sector within the same bank. See the "[Program Suspend/Program Resume Commands](#)" section for more information.

The system must issue the reset command to return a bank to the read (or erase-suspend-read) mode if DQ5 goes high during an active program or erase operation, or if the bank is in the autoselect mode. See the "[Reset Command](#)" section for more information. If DQ1 goes high during Write Buffer Programming, the system must issue the Write Buffer Abort Reset command.

See also "[Requirements for Asynchronous Read Operation \(Non-Burst\)](#)" section and "[Requirements for Synchronous \(Burst\) Read Operation](#)" section for more information. The Asynchronous Read and Synchronous/Burst Read tables provide the read parameters, and [Figure 13](#), [Figure 14](#), and [Figure 18](#) show the timings.

Set Configuration Register Command Sequence

The device uses a configuration register to set the various burst parameters: number of wait states, burst read mode, active clock edge, RDY configuration, and synchronous mode active (see [Figure 16](#) for details). The configuration register must be set before the device will enter burst mode. On power up or reset, the device is set in asynchronous read mode and the configuration register is reset. The configuration register is not reset after deasserting CE#.

The configuration register is loaded with a four-cycle command sequence. The first two cycles are standard unlock sequences. On the third cycle, the data should be D0h and address bits should be 555h. During the fourth cycle, the configuration code should be entered onto the data bus with the address bus set to address 000h. Once the data has been programmed into the configuration register, a software reset command is required to set the device into the correct state. The device will power up or after a hardware reset with the default setting, which is in asynchronous mode. The register must be set before the device can enter

synchronous mode. The configuration register can not be changed during device operations (program, erase, or sector lock).

Read Configuration Register Command Sequence

The configuration register can be read with a four-cycle command sequence. The first two cycles are standard unlock sequences. On the third cycle, the data should be C6h and address bits should be 555h. During the fourth cycle, the configuration code should be read out of the data bus with the address bus set to address 000h. Once the data has been read from the configuration register, a software reset command is required to set the device into the correct state.

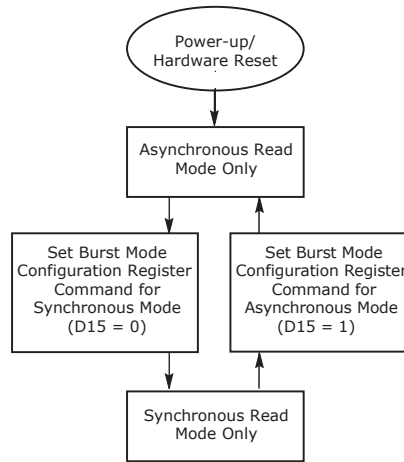

Figure I. Synchronous/Asynchronous State Diagram

Read Mode Setting

This setting allows the system to enable or disable burst mode during system operations. **Configuration Bit CR15** determines this setting: "1" for asynchronous mode, "0" for synchronous mode.

Programmable Wait State Configuration

The programmable wait state feature informs the device of the number of clock cycles that must elapse after AVD# is driven active before data will be available. This value is determined by the input frequency of the device. **Configuration Bit CR13–CR11** determine the setting (see [Table 13](#)).

The wait state command sequence instructs the device to set a particular number of clock cycles for the initial access in burst mode. The number of wait states that should be programmed into the device is directly related to the clock frequency.

Table I3. Programmable Wait State Settings

CR13	CR12	CR11	Total Initial Access Cycles
0	0	0	2
0	0	1	3
0	1	0	4
0	1	1	5
1	0	0	6
1	0	1	7 (default)
1	1	0	Reserved
1	1	1	Reserved

Notes:

1. Upon power-up or hardware reset, the default setting is seven wait states.
2. RDY will default to being active with data when the Wait State Setting is set to a total initial access cycle of 2.

It is recommended that the wait state command sequence be written, even if the default wait state value is desired, to ensure the device is set as expected. A hardware reset will set the wait state to the default setting.

Programmable Wait State

If the device is equipped with the handshaking option, the host system should set **CR13-CR11** to 010 for a clock frequency of 54 MHz or to 011 for a clock frequency of 66 MHz for the system/device to execute at maximum speed.

Table 14 describes the typical number of clock cycles (wait states) for various conditions.

Boundary Crossing Latency

If the device is operating above 66 MHz, an additional wait state must be inserted to account for boundary crossing latency. This is done by setting **CR14** to a '1' (default). If the device is operating at or below 66 MHz, the additional wait state for boundary crossing is not needed. Therefore the **CR14** can be changed to a '0' to remove boundary crossing latency.

Set Internal Clock Frequency

The device switches at the full frequency of the external clock up to 66 MHz when **CR9** is set to a '1' (default).

Table I4. Wait States for Handshaking

Conditions at Address	Typical No. of Clock Cycles after AVD# Low	
	54 MHz	66 MHz
Initial address ($V_{IO} = 1.8 V$)	4	5

Handshaking

For optimal burst mode performance, the host system must set the appropriate number of wait states in the flash device depending on the clock frequency.

The autoselect function allows the host system to determine whether the flash device is enabled for handshaking. See the "Autoselect Command Sequence" section for more information.

Burst Sequence

Only sequential burst is allowed in the device. **CR7** defaults to a '1' and must always be set to a '1'.

Burst Length Configuration

The device supports four different read modes: continuous mode, and 8, 16, and 32 word linear with or without wrap around modes. A continuous sequence (default) begins at the starting address and advances the address pointer until the burst operation is complete. If the highest address in the device is reached during the continuous burst read mode, the address pointer wraps around to the lowest address.

For example, an eight-word linear read with wrap around begins on the starting address written to the device and then advances to the next 8 word boundary. The address pointer then returns to the 1st word after the previous eight word boundary, wrapping through the starting location. The sixteen- and thirty-two linear wrap around modes operate in a fashion similar to the eight-word mode.

Table 15 shows the **CR2-CR0** and settings for the four read modes.

Table 15. Burst Length Configuration

Burst Modes	Address Bits		
	CR2	CR1	CR0
Continuous	0	0	0
8-word linear	0	1	0
16-word linear	0	1	1
32-word linear	1	0	0

Note: Upon power-up or hardware reset the default setting is continuous.

Burst Wrap Around

By default, the device will perform burst wrap around with **CR3** set to a '1'. Changing the **CR3** to a '0' disables burst wrap around.

Burst Active Clock Edge Configuration

By default, the device will deliver data on the rising edge of the clock after the initial synchronous access time. Subsequent outputs will also be on the following rising edges, barring any delays. The device can be set so that the falling clock edge is active for all synchronous accesses. **CR6** determines this setting; "1" for rising active (default), "0" for falling active.

RDY Configuration

By default, the device is set so that the RDY pin will output V_{OH} whenever there is valid data on the outputs. The device can be set so that RDY goes active one data cycle before active data. **CR8** determines this setting; "1" for RDY active (default) with data, "0" for RDY active one clock cycle before valid data. In asynchronous mode, RDY is an open-drain output.

RDY Polarity

By default, the RDY pin will always indicate that the device is ready to handle a new transaction with **CR10** set to a '1' when high. In this case, the RDY pin is active high. Changing the **CR10** to a '0' sets the RDY pin to be active low. In this

case, the RDY pin will always indicate that the device is ready to handle a new transaction when low.

Configuration Register

Table 16 shows the address bits that determine the configuration register settings for various device functions.

Table 16. Configuration Register

CR Bit	Function	Settings (Binary)
CR15	Set Device Read Mode	0 = Synchronous Read (Burst Mode) Enabled 1 = Asynchronous Mode (default)
CR14	Boundary Crossing	0 = No extra boundary crossing latency 1 = With extra boundary crossing latency (default)
CR13	Programmable Wait State	000 = Data is valid on the 2nd active CLK edge after addresses are latched
CR12		001 = Data is valid on the 3rd active CLK edge after addresses are latched
CR11		010 = Data is valid on the 4th active CLK edge after addresses are latched
		011 = Data is valid on the 5th active CLK edge after addresses are latched
		100 = Data is valid on the 6th active CLK edge after addresses are latched
		101 = Data is valid on the 7th active CLK edge after addresses are latched (default)
		110 = Reserved
		111 = Reserved
CR10	RDY Polarity	0 = RDY signal is active low 1 = RDY signal is active high (default)
CR9	Set Internal Clock Frequency	0 = Reserved for Future Use 1 = Internal clock switches at full frequency of the external clock (default)
CR8	RDY	0 = RDY active one clock cycle before data 1 = RDY active with data (default)
CR7	Burst Sequence	0 = Reserved for Future Use 1 = Sequential Burst Order (default)
CR6	Clock	0 = Burst starts and data is output on the falling edge of CLK 1 = Burst starts and data is output on the rising edge of CLK (default)
CR3	Burst Wrap Around	0 = No Wrap Around Burst 1 = Wrap Around Burst (default)
CR2	Burst Length	000 = Continuous (default)
		010 = 8-Word Linear Burst
CR1		011 = 16-Word Linear Burst
		100 = 32-Word Linear Burst
CR0		(All other bit settings are reserved)

Notes: Device will be in the default state upon power-up or hardware reset.

Reset Command

Writing the reset command resets the banks to the read or erase-suspend-read mode. Address bits are don't cares for this command.

The reset command may be written between the sequence cycles in an erase command sequence before erasing begins. This resets the bank to which the system was writing to the read mode. Once erasure begins, however, the device ignores reset commands until the operation is complete.

The reset command may be written between the sequence cycles in a program command sequence before programming begins (prior to the third cycle). This resets the bank to which the system was writing to the read mode. If the program command sequence is written to a bank that is in the Erase Suspend mode, writing the reset command returns that bank to the erase-suspend-read mode. Once programming begins, however, the device ignores reset commands until the operation is complete.

The reset command may be written between the sequence cycles in an autoselect command sequence. Once in the autoselect mode, the reset command must be written to return to the read mode. If a bank entered the autoselect mode while in the Erase Suspend mode, writing the reset command returns that bank to the erase-suspend-read mode.

If DQ5 goes high during a program or erase operation, writing the reset command returns the banks to the read mode (or erase-suspend-read mode if that bank was in Erase Suspend and program-suspend-read mode if that bank was in Program Suspend).

Note: If DQ1 goes high during a Write Buffer Programming operation, the system must write the "Write to Buffer Abort Reset" command sequence to RESET the device to reading array data. The standard RESET command will not work. See Table 17 for details on this command sequence.

Autoselect Command Sequence

The autoselect command sequence allows the host system to access the manufacturer and device codes, and determine whether or not a sector is protected. The "[Command Definition Summary](#)" section shows the address and data requirements. The autoselect command sequence may be written to an address within a bank that is either in the read or erase-suspend-read mode. The autoselect command may not be written while the device is actively programming or erasing in the other bank. Autoselect does not support simultaneous operations nor synchronous mode.

The autoselect command sequence is initiated by first writing two unlock cycles. This is followed by a third write cycle that contains the bank address and the autoselect command. The bank then enters the autoselect mode. The system may read at any address within the same bank any number of times without initiating another autoselect command sequence. Read commands to other banks will return data from the array. Writes to other banks is not allowed. The following table describes the address requirements for the various autoselect functions, and the resulting data. BA represents the bank address. The device ID is read in three cycles.

Table 17. Autoselect Addresses

Description	Address	Read Data
Manufacturer ID	(BA) + 00h	0001h
Device ID, Word 1	(BA) + 01h	227Eh

Table 17. Autoselect Addresses

Description	Address	Read Data
Device ID, Word 2	(BA) + 0Eh	2230 (WS256N)
Device ID, Word 3	(BA) + 0Fh	2200
Indicator Bits	(BA) + 03h	DQ15 - DQ8 = 0 DQ7 - Factory Lock Bit 1 = Locked, 0 = Not Locked DQ6 - Customer Lock Bit 1 = Locked, 0 = Not Locked DQ5 - Handshake Bit 1 = Reserved, 0 = Standard Handshake DQ4 & DQ3 - WP# Protection Boot Code 00 = WP# Protects both Top Boot and Bottom Boot Sectors, 01 = Reserved, 10 = Reserved 11 = Reserved DQ2 = 0 DQ1 - DYB Power up state (DQ1 = Lock Register DQ4) 1 = Unlocked (user option) 0 = Locked (default) DQ0 - PPB Eraseability (DQ0 = Lock Register DQ3) 1 = Erase allowed 0 = Erase disabled

The system must write the reset command to return to the read mode (or erase-suspend-read mode if the bank was previously in Erase Suspend).

Enter SecSi™ Sector/Exit SecSi Sector Command Sequence

The SecSi Sector region provides a secured data area containing a random, eight word electronic serial number (ESN). The system can access the SecSi Sector region by issuing the three-cycle Enter SecSi Sector command sequence. The device continues to access the SecSi Sector region until the system issues the four-cycle Exit SecSi Sector command sequence. The Exit SecSi Sector command sequence returns the device to normal operation. The SecSi Sector is not accessible when the device is executing an Embedded Program or embedded Erase algorithm. The "[Command Definition Summary](#)" section shows the address and data requirements for both command sequences.

Word Program Command Sequence

Programming is a four-bus-cycle operation. The program command sequence is initiated by writing two unlock write cycles, followed by the program set-up command. The program address and data are written next, which in turn initiate the Embedded Program algorithm. The system is *not* required to provide further controls or timings. The device automatically provides internally generated program pulses and verifies the programmed cell margin.

When the Embedded Program algorithm is complete, the device then returns to the read mode and addresses are no longer latched. The system can determine the status of the program operation by using DQ7 or DQ6. Refer to the Write Operation Status section for information on these status bits.

Any commands written to the device during the Embedded Program Algorithm are ignored. **Note that the SecSi Sector, autoselect, and CFI functions are unavailable when a program operation is in progress.** Note that a **hardware reset** immediately terminates the program operation. The program command sequence should be reinitiated once the device has returned to the read mode, to ensure data integrity.

Programming is allowed in any sequence and across sector boundaries. Programming to the same word address multiple times without intervening erases is limited. For such application requirements, please contact your local Spansion representative. **Any word cannot be programmed from "0" back to a "1."** Attempting to do so may cause the device to set DQ5 = 1, or cause the DQ7 and DQ6 status bits to indicate the operation was successful. However, a succeeding read will show that the data is still "0." Only erase operations can convert a "0" to a "1."

Write Buffer Programming Command Sequence

Write Buffer Programming Sequence allows for faster programming compared to the standard Program Command Sequence. Write Buffer Programming allows the system to write 32 words in one programming operation. See the "[Write Buffer Programming Operation](#)" section for the program command sequence.

Table 18. Write Buffer Command Sequence

Sequence	Address	Data	Comment
Unlock Command 1	555	00AA	Not required in the Unlock Bypass mode
Unlock Command 2	2AA	0055	Same as above
Write Buffer Load	Starting Address	0025h	
Specify the Number of Program Locations	Starting Address	Word Count	Number of locations to program minus 1 (must be 32 - 1 = 31)
Load 1st data word	Starting Address	Program Data	All addresses must be within write-buffer-page boundaries, but do not have to be loaded in any order
Load next data word	Write Buffer Location	Program Data	Same as above
...	Same as above
Load last data word	Write Buffer Location	Program Data	Same as above
Write Buffer Program Confirm	Sector Address	0029h	This command must follow the last write buffer location loaded, or the operation will ABORT
Device goes busy			
Status monitoring through DQ pins (Perform Data Bar Polling on the Last Loaded Address)			

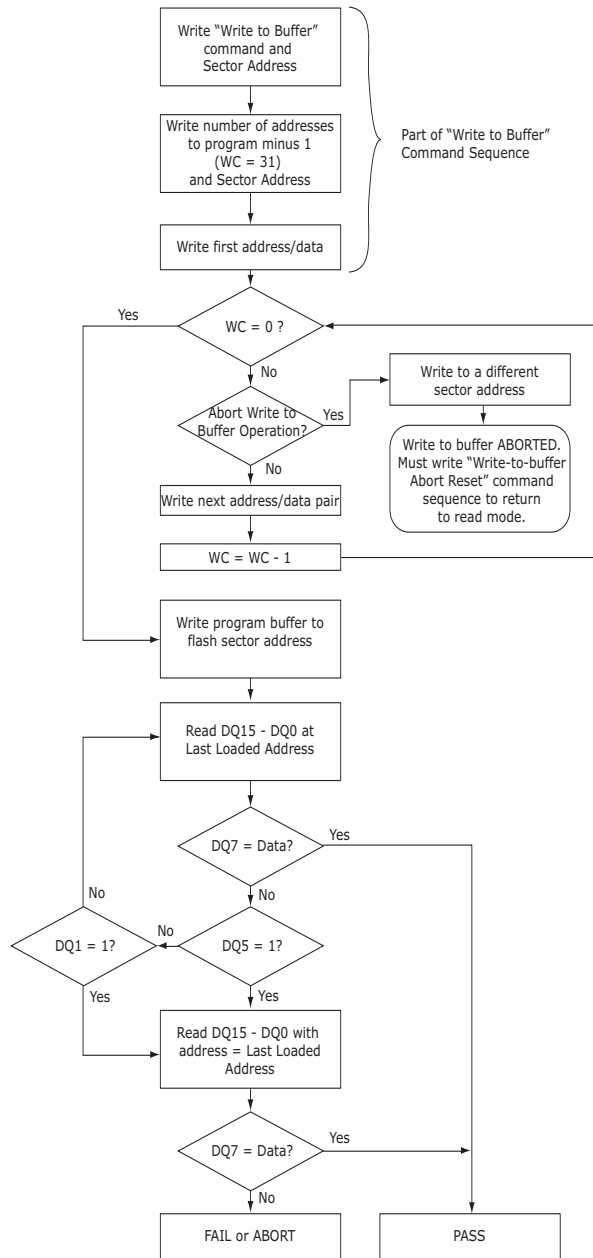

Figure 2. Write Buffer Programming Operation

Unlock Bypass Command Sequence

The unlock bypass feature allows faster programming than the standard program command sequence. The unlock bypass command sequence is initiated by first writing two unlock cycles. This is followed by a third write cycle containing the unlock bypass command, 20h. The device then enters the unlock bypass mode. A two-cycle unlock bypass program command sequence is all that is required to program in this mode. The first cycle in this sequence contains the unlock bypass program command, A0h; the second cycle contains the program address and data. Additional data is programmed in the same manner. This mode dispenses with the initial two unlock cycles required in the standard program command se-

quence, resulting in faster total programming time. The host system may also initiate the chip erase and sector erase sequences in the unlock bypass mode. The erase command sequences are four cycles in length instead of six cycles. The "Command Definition Summary" section shows the requirements for the unlock bypass command sequences.

During the unlock bypass mode, only the Read, Unlock Bypass Program, Unlock Bypass Sector Erase, Unlock Bypass Chip Erase, and Unlock Bypass Reset commands are valid. To exit the unlock bypass mode, the system must issue the two-cycle unlock bypass reset command sequence. The first cycle must contain the bank address and the data 90h. The second cycle need only contain the data 00h. The bank then returns to the read mode.

The device offers accelerated program operations through the ACC input. When the system asserts V_{HH} on this input, the device automatically enters the Unlock Bypass mode. The system may then write the two-cycle Unlock Bypass program command sequence. The device uses the higher voltage on the ACC input to accelerate the operation.

Figure 3 illustrates the algorithm for the program operation. Refer to the Erase/Program Operations table in "AC Characteristics—Asynchronous" for parameters, and Figure 21 for timing diagrams.

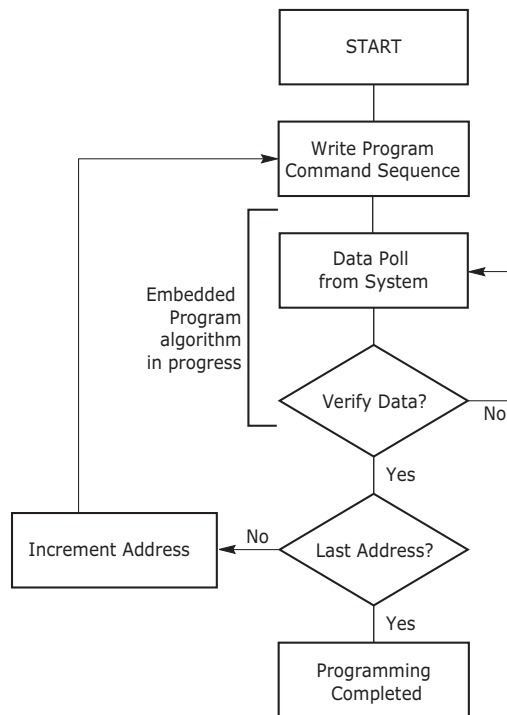

Note: See the "Command Definition Summary" section for program command sequence.

Figure 3. Program Operation

Chip Erase Command Sequence

Chip erase is a six bus cycle operation or, in the unlock bypass mode, a four-cycle operation. The chip erase command sequence is initiated by writing two unlock cycles, followed by a set-up command. Two additional unlock write cycles are then followed by the chip erase command, which in turn invokes the Embedded Erase algorithm. The device does not require the system to preprogram prior to

erase. The Embedded Erase algorithm automatically preprograms and verifies the entire memory for an all zero data pattern prior to electrical erase. The system is not required to provide any controls or timings during these operations. The "[Command Definition Summary](#)" section shows the address and data requirements for the chip erase command sequence.

When the Embedded Erase algorithm is complete, that bank returns to the read mode and addresses are no longer latched. The system can determine the status of the erase operation by using DQ7 or DQ6/DQ2. Refer to "[Write Operation Status](#)" for information on these status bits.

Any commands written during the chip erase operation are ignored. However, note that a **hardware reset** immediately terminates the erase operation. If that occurs, the chip erase command sequence should be reinitiated once that bank has returned to reading array data, to ensure data integrity.

The host system may also initiate the chip erase command sequence while the device is in the unlock bypass mode. The command sequence is two cycles in length instead of six cycles.

[Figure 4](#) illustrates the algorithm for the erase operation. Refer to the "[Erase/Program Operations @ \$V_{IO} = 1.8\text{ V}\$](#) " section for parameters and timing diagrams.

Sector Erase Command Sequence

Sector erase is a six bus cycle operation or, in the unlock bypass mode, a four-cycle operation. The sector erase command sequence is initiated by writing two unlock cycles, followed by a set-up command. Two additional unlock cycles are written, and are then followed by the address of the sector to be erased, and the sector erase command. The "[Command Definition Summary](#)" section shows the address and data requirements for the sector erase command sequence.

The device does not require the system to preprogram prior to erase. The Embedded Erase algorithm automatically programs and verifies the entire memory for an all zero data pattern prior to electrical erase. The system is not required to provide any controls or timings during these operations.

After the command sequence is written, a sector erase time-out of no less than 50 μs occurs. During the time-out period, additional sector addresses and sector erase commands may be written. Loading the sector erase buffer may be done in any sequence, and the number of sectors may be from one sector to all sectors. The time between these additional cycles must be less than 50 μs , otherwise erasure may begin. Any sector erase address and command following the exceeded time-out may or may not be accepted. It is recommended that processor interrupts be disabled during this time to ensure all commands are accepted. The interrupts can be re-enabled after the last Sector Erase command is written. Any command other than Sector Erase or Erase Suspend during the time-out period resets that bank to the read mode. The system must rewrite the command sequence and any additional addresses and commands.

The system can monitor DQ3 to determine if the sector erase timer has timed out (See the "[DQ3: Sector Erase Timer](#)" section.) The time-out begins from the rising edge of the final WE# pulse in the command sequence.

When the Embedded Erase algorithm is complete, the bank returns to reading array data and addresses are no longer latched. Note that while the Embedded Erase operation is in progress, the system can read data from the non-erasing bank. The system can determine the status of the erase operation by reading

DQ7 or DQ6/DQ2 in the erasing bank. Refer to ["Write Operation Status"](#) for information on these status bits.

Once the sector erase operation has begun, only the Erase Suspend command is valid. All other commands are ignored. However, note that a hardware reset immediately terminates the erase operation. If that occurs, the sector erase command sequence should be reinitiated once that bank has returned to reading array data, to ensure data integrity.

The host system may also initiate the sector erase command sequence while the device is in the unlock bypass mode. The command sequence is four cycles in length instead of six cycles.

[Figure 4](#) illustrates the algorithm for the erase operation. Refer to the ["Erase/Program Operations @ \$V_{IO} = 1.8\text{ V}\$ "](#) section for parameters and timing diagrams.

Erase Suspend/Erase Resume Commands

The Erase Suspend command allows the system to interrupt a sector erase operation and then read data from, or program data to, any sector not selected for erasure. The bank address is required when writing this command. This command is valid only during the sector erase operation, including the minimum 50 μs time-out period during the sector erase command sequence. The Erase Suspend command is ignored if written during the chip erase operation or Embedded Program algorithm.

When the Erase Suspend command is written during the sector erase operation, the device requires a maximum of 20 μs to suspend the erase operation. However, when the Erase Suspend command is written during the sector erase time-out, the device immediately terminates the time-out period and suspends the erase operation.

After the erase operation has been suspended, the bank enters the erase-suspend-read mode. The system can read data from or program data to any sector not selected for erasure. (The device "erase suspends" all sectors selected for erasure.) Reading at any address within erase-suspended sectors produces status information on DQ7–DQ0. The system can use DQ7, or DQ6 and DQ2 together, to determine if a sector is actively erasing or is erase-suspended. Refer to [Table 20](#) for information on these status bits.

After an erase-suspended program operation is complete, the bank returns to the erase-suspend-read mode. The system can determine the status of the program operation using the DQ7 or DQ6 status bits, just as in the standard program operation.

In the erase-suspend-read mode, the system can also issue the autoselect command sequence. Refer to the ["Write Buffer Programming Operation"](#) section and the ["Autoselect Command Sequence"](#) section for details.

To resume the sector erase operation, the system must write the Erase Resume command. The bank address of the erase-suspended bank is required when writing this command. Further writes of the Resume command are ignored. Another Erase Suspend command can be written after the chip has resumed erasing.

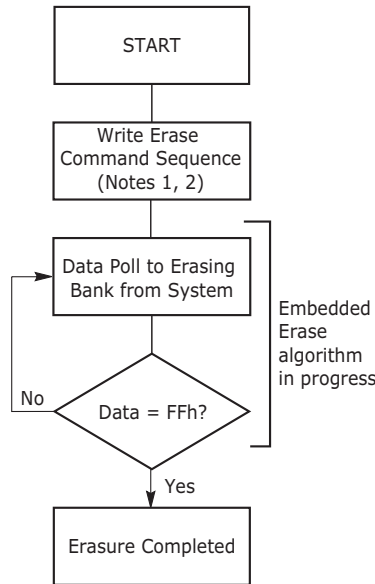

Notes:

1. See the "Command Definition Summary" section for erase command sequence.
2. See the section on DQ3 for information on the sector erase timer.

Figure 4. Erase Operation

Program Suspend/Program Resume Commands

The Program Suspend command allows the system to interrupt an embedded programming operation or a "Write to Buffer" programming operation so that data can read from any non-suspended sector. When the Program Suspend command is written during a programming process, the device halts the programming operation within 20 μs and updates the status bits. Addresses are "don't-cares" when writing the Program Suspend command.

After the programming operation has been suspended, the system can read array data from any non-suspended sector. The Program Suspend command may also be issued during a programming operation while an erase is suspended. In this case, data may be read from any addresses not in Erase Suspend or Program Suspend. If a read is needed from the SecSi Sector area, then user must use the proper command sequences to enter and exit this region.

The system may also write the autoselect command sequence when the device is in Program Suspend mode. The device allows reading autoselect codes in the suspended sectors, since the codes are not stored in the memory array. When the device exits the autoselect mode, the device reverts to Program Suspend mode, and is ready for another valid operation. See "Autoselect Command Sequence" for more information.

After the Program Resume command is written, the device reverts to programming. The system can determine the status of the program operation using the DQ7 or DQ6 status bits, just as in the standard program operation. See "Write Operation Status" for more information.

The system must write the Program Resume command (address bits are "don't care") to exit the Program Suspend mode and continue the programming operation. Further writes of the Program Resume command are ignored. Another

Program Suspend command can be written after the device has resumed programming.

Lock Register Command Set Definitions

The Lock Register Command Set permits the user to program the SecSi Sector Protection Bit, Persistent Protection Mode Lock Bit, or Password Protection Mode Lock Bit one time. The Lock Command Set also allows for the reading of the SecSi Sector Protection Bit, Persistent Protection Mode Lock Bit, or Password Protection Mode Lock Bit.

The **Lock Register Command Set Entry** command sequence must be issued prior to any of the following commands to enable proper command execution.

- Lock Register Program Command
- Lock Register Read Command
- Lock Register Exit Command

Note that issuing the **Lock Register Command Set Entry** command disables reads and writes for Bank 0. Reads from other banks excluding Bank 0 are allowed.

The **Lock Register Command Set Exit** command must be issued after the execution of the commands to reset the device to read mode. Otherwise the device will hang.

For either the SecSi Sector to be locked, or the device to be permanently set to the Persistent Protection Mode or the Password Protection Mode, the sequence of a **Lock Register Command Set Exit command**, must be initiated after issuing the **SecSi Protection Bit Program, Persistent Protection Mode Locking Bit Program**, or the **Password Protection Mode Locking Bit Program** commands. Note that if the **Persistent Protection Mode Locking Bit** and the **Password Protection Mode Locking Bit** are programmed at the same time, neither will be programmed.

Note that issuing the **Lock Register Command Set Exit** command re-enables reads and writes for Bank 0.

Password Protection Command Set Definitions

The Password Protection Command Set permits the user to program the 64-bit password, verify the programming of the 64-bit password, and then later unlock the device by issuing the valid 64-bit password.

The **Password Protection Command Set Entry** command sequence must be issued prior to any of the following commands to enable proper command execution.

- Password Program Command
- Password Read Command
- Password Unlock Command

Note that issuing the **Password Protection Command Set Entry** command disables reads and writes for Bank 0. Reads and Writes for other banks excluding Bank 0 are allowed.

The Password Program Command permits programming the password that is used as part of the hardware protection scheme. The actual password is 64-bits long. There is no special addressing order required for programming the password.

Once the Password is written and verified, the Password Mode Locking Bit must be set in order to prevent verification. The Password Program Command is only capable of programming "0"s. Programming a "1" after a cell is programmed as a "0" results in a time-out by the Embedded Program Algorithm™ with the cell remaining as a "0". The password is all F's when shipped from the factory. All 64-bit password combinations are valid as a password.

The Password Verify Command is used to verify the Password. The Password is verifiable only when the Password Mode Locking Bit is not programmed. If the Password Mode Locking Bit is programmed and the user attempts to verify the Password, the device will always drive all F's onto the DQ data bus.

The lower two address bits (A1–A0) are valid during the Password Read, Password Program, and Password Unlock.

The Password Unlock command is used to clear the PPB Lock Bit so that the PPBs can be unlocked for modification, thereby allowing the PPBs to become accessible for modification. The exact password must be entered in order for the unlocking function to occur. This command cannot be issued any faster than 1 μs at a time to prevent a hacker from running through all the 64-bit combinations in an attempt to correctly match a password. If the command is issued before the 1 μs execution window for each portion of the unlock, the command will be ignored.

The Password Unlock function is accomplished by writing Password Unlock command and data to the device to perform the clearing of the PPB Lock Bit. The password is 64 bits long. A1 and A0 are used for matching. Writing the Password Unlock command does not need to be address order specific. An example sequence is starting with the lower address A1–A0= 00, followed by A1–A0= 01, A1–A0= 10, and A1–A0= 11.

Approximately 1 μSec is required for unlocking the device after the valid 64-bit password is given to the device. It is the responsibility of the microprocessor to keep track of the 64-bit password as it is entered with the Password Unlock command, the order, and when to read the PPB Lock bit to confirm successful password unlock. In order to re-lock the device into the Password Mode, the PPB Lock Bit Set command can be re-issued.

The **Password Protection Command Set Exit** command must be issued after the execution of the commands listed previously to reset the device to read mode. Otherwise the device will hang.

Note that issuing the **Password Protection Command Set Exit** command re-enables reads and writes for Bank 0.

Non-Volatile Sector Protection Command Set Definitions

The Non-Volatile Sector Protection Command Set permits the user to program the Persistent Protection Bits (PPBs), erase all of the Persistent Protection Bits (PPBs), and read the logic state of the Persistent Protection Bits (PPBs).

The **Non-Volatile Sector Protection Command Set Entry** command sequence must be issued prior to any of the following commands to enable proper command execution.

- PPB Program Command
- All PPB Erase Command
- PPB Status Read Command

Note that issuing the **Non-Volatile Sector Protection Command Set Entry** command disables reads and writes for the bank selected. Reads within that

bank, will return the PPB status for that sector. Writes within that bank, will set the PPB for that sector. Reads from other banks are allowed, writes are not allowed. All Reads must be performed using the Asynchronous mode.

The PPB Program command is used to program, or set, a given PPB. Each PPB is individually programmed (but is bulk erased with the other PPBs). The specific sector address (A23–A14 WS256N) are written at the same time as the program command. If the PPB Lock Bit is set, the PPB Program command will not execute and the command will time-out without programming the PPB.

The All PPB Erase command is used to erase all PPBs in bulk. There is no means for individually erasing a specific PPB. Unlike the PPB program, no specific sector address is required. However, when the PPB erase command is written, all Sector PPBs are erased in parallel. If the PPB Lock Bit is set the ALL PPB Erase command will not execute and the command will time-out without erasing the PPBs.

The device will preprogram all PPBs prior to erasing when issuing the All PPB Erase command. Also note that the total number of PPB program/erase cycles has the same endurance as the flash memory array.

The programming state of the PPB for a given sector can be verified by writing a PPB Status Read Command to the device.

The **Non-Volatile Sector Protection Command Set Exit** command must be issued after the execution of the commands listed previously to reset the device to read mode.

Note that issuing the **Non-Volatile Sector Protection Command Set Exit** command re-enables reads and writes for Bank 0.

Global Volatile Sector Protection Freeze Command Set

The Global Volatile Sector Protection Freeze Command Set permits the user to set the PPB Lock Bit and reading the logic state of the PPB Lock Bit.

The **Volatile Sector Protection Freeze Command Set Entry** command sequence must be issued prior to any of the commands listed following to enable proper command execution.

- PPB Lock Bit Set Command
- PPB Lock Bit Status Read Command

Reads from all banks are allowed.

The PPB Lock Bit Set command is used to set the PPB Lock bit if it is cleared either at reset or if the Password Unlock command was successfully executed. There is no PPB Lock Bit Clear command. Once the PPB Lock Bit is set, it cannot be cleared unless the device is taken through a power-on clear (for Persistent Sector Protection Mode) or the Password Unlock command is executed (for Password Sector Protection Mode). If the Password Mode Locking Bit is set, the PPB Lock Bit status is reflected as set, even after a power-on reset cycle.

The programming state of the PPB Lock Bit can be verified by executing a PPB Lock Bit Status Read Command to the device.

The **Global Volatile Sector Protection Freeze Command Set Exit** command must be issued after the execution of the commands listed previously to reset the device to read mode.

Volatile Sector Protection Command Set

The Volatile Sector Protection Command Set permits the user to set the Dynamic Protection Bit (DYB), clear the Dynamic Protection Bit (DYB), and read the logic state of the Dynamic Protection Bit (DYB).

The **Volatile Sector Protection Command Set Entry** command sequence must be issued prior to any of the following commands to enable proper command execution.

- DYB Set Command
- DYB Clear Command
- DYB Status Read Command

Note that issuing the **Volatile Sector Protection Command Set Entry** command disables reads and writes for the bank selected with the command. Reads within that bank, will return the DYB status for that sector. Writes within that bank, will set the DYB for that sector. Reads for other banks excluding that bank are allowed, writes are not allowed. All Reads must be performed using the Asynchronous mode.

The DYB Set/Clear command is used to set or clear a DYB for a given sector. The high order address bits (A23–A14 for the WS256N) are issued at the same time as the code 00h or 01h on DQ7–DQ0. All other DQ data bus pins are ignored during the data write cycle. The DYBs are modifiable at any time, regardless of the state of the PPB or PPB Lock Bit. The DYBs are cleared at power-up or hardware reset.

The programming state of the DYB for a given sector can be verified by writing a DYB Status Read Command to the device.

The **Volatile Sector Protection Command Set Exit** command must be issued after the execution of the commands listed previously to reset the device to read mode.

Note that issuing the **Volatile Sector Protection Command Set Exit** command re-enables reads and writes for Bank 0.

SecSi Sector Entry Command

The SecSi Sector Entry Command allows the following commands to be executed

- Read from SecSi Sector
- Program to SecSi Sector

Sector 0 is remapped from memory array to SecSi Sector array. Reads can be performed using the Asynchronous or Synchronous mode. Burst mode reads within SecSi Sector will wrap from address FFh back to address 00h. Reads outside of sector 0 will return memory array data. Continuous burst read past the maximum address is undefined.

Simultaneous operations are allowed except for Bank 0. Once the SecSi Sector Entry Command is issued, the SecSi Sector Exit command has to be issued to exit SecSi Sector Mode.

Command Definition Summary

Command Sequence (Note 1)		Cycles	Bus Cycles (Notes 1-6)													
			First		Second		Third		Fourth		Fifth		Sixth		Seventh	
			Addr	Data	Addr	Data	Addr	Data	Addr	Data	Addr	Data	Addr	Data	Addr	Data
Asynchronous Read (Note 7)		1	RA	RD												
Reset (Note 8)		1	XXX	F0												
Autoselect (Note 9)	Manufacturer ID	4	555	AA	2AA	55	(BA) 555	90	(BA) X00	0001						
	Device ID (Note 10)	6	555	AA	2AA	55	(BA) 555	90	(BA) X01	227E	(BA) X0E	(Note 10)	(BA) X0F	2200		
	Indicator Bits	4	555	AA	2AA	55	(BA) 555	90	(BA) X03	(Note 12)						
Program		4	555	AA	2AA	55	555	A0	PA	Data						
Write to Buffer (Note 18)		6	555	AA	2AA	55	PA	25	PA	WC	PA	PD	WBL	PD		
Program Buffer to Flash		1	SA	29												
Write to Buffer Abort Reset (Note 22)		3	555	AA	2AA	55	555	F0								
Chip Erase		6	555	AA	2AA	55	555	80	555	AA	2AA	55	555	10		
Sector Erase		6	555	AA	2AA	55	555	80	555	AA	2AA	55	SA	30		
Erase/Program Suspend (Note 15)		1	BA	B0												
Erase/Program Resume (Note 16)		1	BA	30												
Set Configuration Register		4	555	AA	2AA	55	555	D0	X00	CR						
Read Configuration Register		4	555	AA	2AA	55	555	C6	X00	CR						
CFI Query (Note 18)		1	(BA) 555	98												
Unlock Bypass Mode	Unlock Bypass Entry (Note 24)	3	555	AA	2AA	55	555	20								
	Unlock Bypass Program (Notes 13, 14)	2	XX	A0	PA	PD										
	Unlock Bypass Sector Erase (Notes 13, 14)	2	XX	80	SA	30										
	Unlock Bypass Erase (Notes 13, 14)	2	XX	80	XXX	10										
	Unlock Bypass CFI (Notes 13, 14)	1	XX	98												
	Unlock Bypass Reset	2	XX	90	XXX	00										
SecSi Sector Command Definitions																
SecSi Sector	SecSi Sector Entry (Note 23)	3	555	AA	2AA	55	555	88								
	SecSi Sector Program	6	555	AA	2AA	55	SA	25	SA	WC	PA	PD	WBL	PD		
	SecSi Sector Read	1	00	data												
	SecSi Sector Exit (Note 26)	4	555	AA	2AA	55	555	90	XX	00						
Lock Register Command Set Definitions																
Lock	Lock Register Command Set Entry (Note 23)	3	555	AA	2AA	55	555	40								
	Lock Register Bits Program (Note 25)	2	XX	A0	⁷⁷ (Note 25)	data										
	Lock Register Bits Read (Note 25)	1	⁷⁷ (Note 25)	data												
	Lock Register Command Set Exit (Note 26)	2	XX	90	XX	00										

(Continued)

Command Sequence (Note 1)		Cycles	Bus Cycles (Notes 1-6)													
			First		Second		Third		Fourth		Fifth		Sixth		Seventh	
			Addr	Data	Addr	Data	Addr	Data	Addr	Data	Addr	Data	Addr	Data	Addr	Data
Password Protection Command Set Definitions																
Password	Password Protection Command Set Entry (Note 23)	3	555	AA	2AA	55	555	60								
	Password Program*	2	XX	A0	00	PWD 0										
			XX	A0	01	PWD 1										
			XX	A0	02	PWD 2										
			XX	A0	03	PWD 3										
	Password Read**	4	00	PWD 0	01	PWD 1	02	PWD 2	03	PWD 3						
Password Unlock***	7	00	25	00	03	00	PWD 0	01	PWD 1	02	PWD 2	03	PWD 3	00	29	
Password Protection Command Set Exit (Note 26)	2	XX	90	XX	00											
Non-Volatile Sector Protection Command Set Definitions																
PPB	Non-Volatile Sector Protection Command Set Entry (Note 23)	3	555	AA	2AA	55	(BA) 555	C0								
	PPB Program	2	XX	A0	(BA) SA	00										
	All PPB Erase (Note 20)	2	XX	80	XX	30										
	PPB Status Read	1	(BA) SA	RD (0)												
	Non-Volatile Sector Protection Command Set Exit (Note 26)	2	XX	90	XX	00										
Global Non-Volatile Sector Protection Freeze Command Set Definitions																
PPB Lock Bit	Global Volatile Sector Protection Freeze Command Set Entry (Note 23)	3	555	AA	2AA	55	555	50								
	PPB Lock Bit Set	2	XX	A0	XX	00										
	PPB Lock Bit Status Read	1	XX	RD (0)												
	Global Volatile Sector Protection Freeze Command Set Exit (Note 26)	2	XX	90	XX	00										

* Only A7-A0 used during 2nd cycle
 ** Amax-A0 used during 1st, 2nd, 3rd, 4th cycle
 *** Only A7-A0 used during 3rd, 4th, 5th 6th cycle

Volatile Sector Protection Command Set Definitions																
DYB	Volatile Sector Protection Command Set Entry (Note 23)	3	555	AA	2AA	55	(BA) 555	E0								
	DYB Set	2	XX	A0	(BA) SA	00										
	DYB Clear	2	XX	A0	(BA) SA	01										
	DYB Status Read	1	(BA) SA	RD (0)												
	Volatile Sector Protection Command Set Exit (Note 26)	2	XX	90	XX	00										

Legend:

X = Don't care

RA = Address of the memory location to be read.

RD = Data read from location RA during read operation.

PA = Address of the memory location to be programmed. Addresses latch on the rising edge of the AVD# pulse or active edge of CLK which ever comes first.

PD = Data to be programmed at location PA. Data latches on the rising edge of WE# or CE# pulse, whichever happens first.

PD(0) = SecSi Sector Lock Bit. PD(0), or bit[0].

PD(1) = Persistent Protection Mode Lock Bit. PD(1), or bit[1], must be set to '0' for protection while PD(2), bit[2] must be left as '1'.

PD(2) = Password Protection Mode Lock Bit. PD(2), or bit[2], must be set to '0' for protection while PD(1), bit[1] must be left as '1'.

PD(3) = Protection Mode OTP Bit. PD(3) or bit[3].

SA = Address of the sector to be verified (in autoselect mode) or erased. Address bits A23-A14 for the WS256N uniquely select any sector.

Notes:

1. See [Table 2](#) for description of bus operations.
2. All values are in hexadecimal.
3. Except for the following, all bus cycles are write cycle: read cycle, fourth through sixth cycles of the Autoselect commands, fourth cycle of the configuration register verify and password verify commands, and any cycle reading at RD(0) and RD(1).
4. Data bits DQ15-DQ8 are don't care in command sequences, except for RD, PD, WD, PWD, and PWD3-PWD0.
5. Unless otherwise noted, address bits A23-A12 for the WS256N are don't cares.
6. Writing incorrect address and data values or writing them in the improper sequence may place the device in an unknown state. The system must write the reset command to return the device to reading array data.
7. No unlock or command cycles required when bank is reading array data.
8. The Reset command is required to return to reading array data (or to the erase-suspend-read mode if previously in Erase Suspend) when a bank is in the autoselect mode, or if DQ5 goes high (while the bank is providing status information) or performing sector lock/unlock.
9. The fourth cycle of the autoselect command sequence is a read cycle. The system must provide the bank address. See the "Autoselect Command Sequence" section
10. WS25N6 = 2230
11. The data is 0000h for an unlocked sector and 0001h for a locked sector
12. See the "Autoselect Command Sequence" section
13. The Unlock Bypass command sequence is required prior to this command sequence.
14. The Unlock Bypass Reset command is required to return to reading array data when the bank is in the unlock bypass mode.
15. The system may read and program in non-erasing sectors, or enter the autoselect mode, when in the Erase Suspend mode. The Erase Suspend command is valid only during a sector erase operation, and requires the bank address.
16. The Erase Resume command is valid only during the Erase Suspend mode, and requires the bank address.
17. Command is valid when device is ready to read array data or when device is in autoselect mode.

BA = Address of the bank (A23, A22, A21, and A20 for the WS256N/ A22, A21, A20, that is being switched to autoselect mode, is in bypass mode, or is being erased.

CR = Configuration Register data bits DQ15-DQ0.

PWD3-PWD0 = Password Data. PD3-PD0 present four 16 bit combinations that represent the 64-bit Password

PWA = Password Address. Address bits A1 and A0 are used to select each 16-bit portion of the 64-bit entity.

PWD = Password Data.

RD(0) = DQ0 protection indicator bit. If protected, DQ0 = 0, if unprotected, DQ0 = 1.

RD(1) = DQ1 protection indicator bit. If protected, DQ1 = 0, if unprotected, DQ1 = 1.

RD(2) = DQ2 protection indicator bit. If protected, DQ2 = 0, if unprotected, DQ2 = 1.

WBL = Write Buffer Location. Address must be within the same write buffer page as PA.]

WC = Word Count. Number of write buffer locations to load minus 1.

18. The total number of cycles in the command sequence is determined by the number of words written to the write buffer. The number of cycles in the command sequence is 37 for full page programming (32 words). Less than 32 word programming is not recommended.
19. The entire four bus-cycle sequence must be entered for which portion of the password.
20. The ALL PPB ERASE command will pre-program all PPBs before erasure to prevent over-erasure of PPBs.
21. ACC must be at V_{HH} during the entire operation of this command
22. Command sequence resets device for next command after write-to-buffer operation.
23. Entry commands are needed to enter a specific mode to enable instructions only available within that mode.
24. Write Buffer Programming can be initiated after Unlock Bypass Entry.
25. If both the Persistent Protection Mode Locking Bit and the password Protection Mode Locking Bit are set at the same time, the command operation will abort and return the device to the default Persistent Sector Protection Mode during 2nd Bus cycle. Addresses will equal 00h on all future devices, but 77h for WS256N.
26. The Exit command must be issued to reset the device into read mode. Otherwise the device will hang.

Write Operation Status

The device provides several bits to determine the status of a program or erase operation: DQ1, DQ2, DQ3, DQ5, DQ6, and DQ7. [Table 20](#) and the following subsections describe the function of these bits. DQ7 and DQ6 each offers a method for determining whether a program or erase operation is complete or in progress.

DQ7: Data# Polling

The Data# Polling bit, DQ7, indicates to the host system whether an Embedded Program or Erase algorithm is in progress or completed, or whether a bank is in Erase Suspend. Data# Polling is valid after the rising edge of the final WE# pulse in the command sequence. **Note that the Data# Polling is valid only for the last word being programmed in the write-buffer-page during Write Buffer Programming. Reading Data# Polling status on any word other than the last word to be programmed in the write-buffer-page will return false status information.**

During the Embedded Program algorithm, the device outputs on DQ7 the complement of the datum programmed to DQ7. This DQ7 status also applies to programming during Erase Suspend. When the Embedded Program algorithm is complete, the device outputs the datum programmed to DQ7. The system must provide the program address to read valid status information on DQ7. If a program address falls within a protected sector, Data# Polling on DQ7 is active for approximately 1 μ s, then that bank returns to the read mode.

During the Embedded Erase algorithm, Data# Polling produces a "0" on DQ7. When the Embedded Erase algorithm is complete, or if the bank enters the Erase Suspend mode, Data# Polling produces a "1" on DQ7. The system must provide an address within any of the sectors selected for erasure to read valid status information on DQ7.

After an erase command sequence is written, if all sectors selected for erasing are protected, Data# Polling on DQ7 is active for approximately 100 μ s, then the bank returns to the read mode. If not all selected sectors are protected, the Embedded Erase algorithm erases the unprotected sectors, and ignores the selected sectors that are protected. However, if the system reads DQ7 at an address within a protected sector, the status may not be valid.

Just prior to the completion of an Embedded Program or Erase operation, DQ7 may change asynchronously with DQ6–DQ0 while Output Enable (OE#) is asserted low. That is, the device may change from providing status information to valid data on DQ7. Depending on when the system samples the DQ7 output, it may read the status or valid data. Even if the device has completed the program or erase operation and DQ7 has valid data, the data outputs on DQ6–DQ0 may be still invalid. Valid data on DQ7–DQ0 will appear on successive read cycles.

[Table 20](#) shows the outputs for Data# Polling on DQ7. [Figure 5](#) shows the Data# Polling algorithm. [Figure 24](#) in "AC Characteristics—Asynchronous" shows the Data# Polling timing diagram.

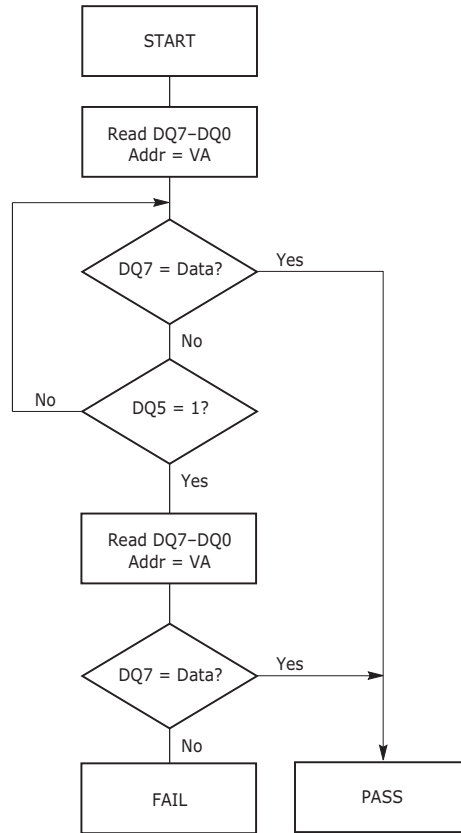

Figure 5. Data# Polling Algorithm

RDY: Ready

The RDY is a dedicated output, controlled by CE#, that indicates the number of clock cycles in the system should write before expecting valid data. When the device is configured in the Synchronous mode and RDY is at logic low, the system should wait 1 clock cycle before expecting the next word of data. Using the RDY Configuration Command Sequence, RDY can be set so that a logic low indicates the system should wait 2 clock cycles before expecting valid data.

The RDY output is at logic low if the frequency is greater than 66 MHz during the initial access in burst mode and at the boundary crossing that occurs every 128 words beginning with address 7Fh.

DQ6: Toggle Bit I

Toggle Bit I on DQ6 indicates whether an Embedded Program or Erase algorithm is in progress or complete, or whether the device has entered the Erase Suspend mode. Toggle Bit I may be read at any address in the same bank, and is valid after the rising edge of the final WE# pulse in the command sequence (prior to the program or erase operation), and during the sector erase time-out.

During an Embedded Program or Erase algorithm operation, successive read cycles to any address cause DQ6 to toggle. When the operation is complete, DQ6 stops toggling.

After an erase command sequence is written, if all sectors selected for erasing are protected, DQ6 toggles for approximately 100 μs, then returns to reading

array data. If not all selected sectors are protected, the Embedded Erase algorithm erases the unprotected sectors, and ignores the selected sectors that are protected.

The system can use DQ6 and DQ2 together to determine whether a sector is actively erasing or is erase-suspended. When the device is actively erasing (that is, the Embedded Erase algorithm is in progress), DQ6 toggles. When the device enters the Erase Suspend mode, DQ6 stops toggling. However, the system must also use DQ2 to determine which sectors are erasing or erase-suspended. Alternatively, the system can use DQ7 (see the subsection on DQ7: Data# Polling).

If a program address falls within a protected sector, DQ6 toggles for approximately 1 ms after the program command sequence is written, then returns to reading array data.

DQ6 also toggles during the erase-suspend-program mode, and stops toggling once the Embedded Program algorithm is complete.

See the following for additional information: [Figure 6](#), "DQ6: Toggle Bit I" section, [Figure 25](#) (toggle bit timing diagram), and [Table 19](#).

Toggle Bit I on DQ6 requires either OE# or CE# to be deasserted and reasserted to show the change in state.

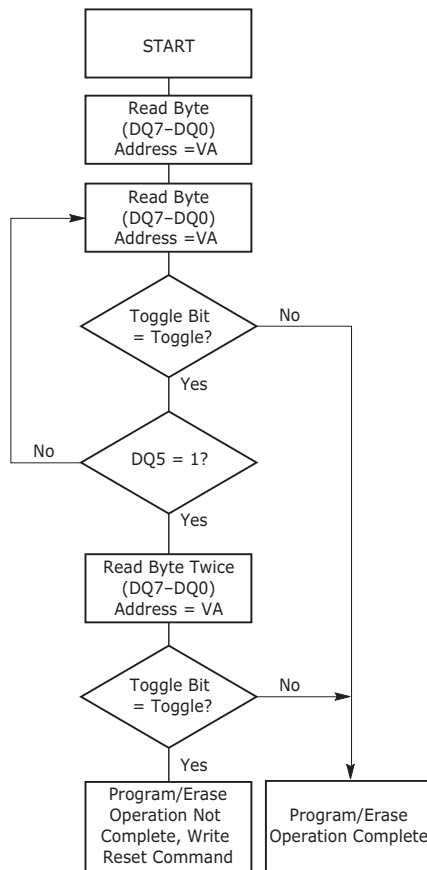

Note: The system should recheck the toggle bit even if DQ5 = "1" because the toggle bit may stop toggling as DQ5 changes to "1." See the subsections on DQ6 and DQ2 for more information.

Figure 6. Toggle Bit Algorithm

DQ2: Toggle Bit II

The "Toggle Bit II" on DQ2, when used with DQ6, indicates whether a particular sector is actively erasing (that is, the Embedded Erase algorithm is in progress), or whether that sector is erase-suspended. Toggle Bit II is valid after the rising edge of the final WE# pulse in the command sequence.

DQ2 toggles when the system reads at addresses within those sectors that have been selected for erasure. But DQ2 cannot distinguish whether the sector is actively erasing or is erase-suspended. DQ6, by comparison, indicates whether the device is actively erasing, or is in Erase Suspend, but cannot distinguish which sectors are selected for erasure. Thus, both status bits are required for sector and mode information. Refer to [Table 19](#) to compare outputs for DQ2 and DQ6.

See the following for additional information: [Figure 6](#), the "DQ6: Toggle Bit I" section, and [Figure 25](#).

Table 19. DQ6 and DQ2 Indications

If device is	and the system reads	then DQ6	and DQ2
programming,	at any address,	toggles,	does not toggle.
actively erasing,	at an address within a sector selected for erasure,	toggles,	also toggles.
	at an address within sectors <i>not</i> selected for erasure,	toggles,	does not toggle.
erase suspended,	at an address within a sector selected for erasure,	does not toggle,	toggles.
	at an address within sectors <i>not</i> selected for erasure,	returns array data,	returns array data. The system can read from any sector not selected for erasure.
programming in erase suspend	at any address,	toggles,	is not applicable.

Reading Toggle Bits DQ6/DQ2

Whenever the system initially begins reading toggle bit status, it must read DQ7–DQ0 at least twice in a row to determine whether a toggle bit is toggling. Typically, the system would note and store the value of the toggle bit after the first read. After the second read, the system would compare the new value of the toggle bit with the first. If the toggle bit is not toggling, the device has completed the program or erase operation. The system can read array data on DQ7–DQ0 on the following read cycle.

However, if after the initial two read cycles, the system determines that the toggle bit is still toggling, the system also should note whether the value of DQ5 is high (see the section on DQ5). If it is, the system should then determine again whether the toggle bit is toggling, since the toggle bit may have stopped toggling just as DQ5 went high. If the toggle bit is no longer toggling, the device has successfully completed the program or erase operation. If it is still toggling, the device did not completed the operation successfully, and the system must write the reset command to return to reading array data.

The remaining scenario is that the system initially determines that the toggle bit is toggling and DQ5 has not gone high. The system may continue to monitor the toggle bit and DQ5 through successive read cycles, determining the status as described in the previous paragraph. Alternatively, it may choose to perform other

system tasks. In this case, the system must start at the beginning of the algorithm when it returns to determine the status of the operation. Refer to [Figure 6](#) for more details.

DQ5: Exceeded Timing Limits

DQ5 indicates whether the program or erase time has exceeded a specified internal pulse count limit. Under these conditions DQ5 produces a "1," indicating that the program or erase cycle was not successfully completed.

The device may output a "1" on DQ5 if the system tries to program a "1" to a location that was previously programmed to "0." Only an erase operation can change a "0" back to a "1." Under this condition, the device halts the operation, and when the timing limit has been exceeded, DQ5 produces a "1."

Under both these conditions, the system must write the reset command to return to the read mode (or to the erase-suspend-read mode if a bank was previously in the erase-suspend-program mode).

DQ3: Sector Erase Timer

After writing a sector erase command sequence, the system may read DQ3 to determine whether or not erasure has begun. (The sector erase timer does not apply to the chip erase command.) If additional sectors are selected for erasure, the entire time-out also applies after each additional sector erase command. When the time-out period is complete, DQ3 switches from a "0" to a "1." If the time between additional sector erase commands from the system can be assumed to be less than 50 μ s, the system need not monitor DQ3. See the "[Sector Erase Command Sequence](#)" section for more details.

After the sector erase command is written, the system should read the status of DQ7 (Data# Polling) or DQ6 (Toggle Bit I) to ensure that the device has accepted the command sequence, and then read DQ3. If DQ3 is "1," the Embedded Erase algorithm has begun; all further commands (except Erase Suspend) are ignored until the erase operation is complete. If DQ3 is "0," the device will accept additional sector erase commands. To ensure the command has been accepted, the system software should check the status of DQ3 prior to and following each subsequent sector erase command. If DQ3 is high on the second status check, the last command might not have been accepted.

[Table 20](#) shows the status of DQ3 relative to the other status bits.

DQ1: Write to Buffer Abort

DQ1 indicates whether a Write to Buffer operation was aborted. Under these conditions DQ1 produces a '1'. The system must issue the Write to Buffer Abort Reset command sequence to return the device to reading array data. See the "[Write Buffer Programming Operation](#)" section for more details.

Table 20. Write Operation Status

Status		DQ7 (Note 2)	DQ6	DQ5 (Note 1)	DQ3	DQ2 (Note 2)	DQ1 (Note 4)	
Standard Mode	Embedded Program Algorithm	DQ7#	Toggle	0	N/A	No toggle	0	
	Embedded Erase Algorithm	0	Toggle	0	1	Toggle	N/A	
Program Suspend Mode (Note 3)	Reading within Program Suspended Sector	INVALID (Not Allowed)	INVALID (Not Allowed)	INVALID (Not Allowed)	INVALID (Not Allowed)	INVALID (Not Allowed)	INVALID (Not Allowed)	
	Reading within Non-Program Suspended Sector	Data	Data	Data	Data	Data	Data	
Erase Suspend Mode	Erase-Suspend-Read	Erase Suspended Sector	1	No toggle	0	N/A	Toggle	N/A
		Non-Erase Suspended Sector	Data	Data	Data	Data	Data	Data
	Erase-Suspend-Program		DQ7#	Toggle	0	N/A	N/A	N/A
Write to Buffer (Note 5)	BUSY State	DQ7#	Toggle	0	N/A	N/A	0	
	Exceeded Timing Limits	DQ7#	Toggle	1	N/A	N/A	0	
	ABORT State	DQ7#	Toggle	0	N/A	N/A	1	

Notes:

1. DQ5 switches to '1' when an Embedded Program or Embedded Erase operation has exceeded the maximum timing limits. Refer to the section on DQ5 for more information.
2. DQ7 and DQ2 require a valid address when reading status information. Refer to the appropriate subsection for further details.
3. Data are invalid for addresses in a Program Suspended sector.
4. DQ1 indicates the Write to Buffer ABORT status during Write Buffer Programming operations.
5. The data-bar polling algorithm should be used for Write Buffer Programming operations. Note that DQ7# during Write Buffer Programming indicates the data-bar for DQ7 data **for the LAST LOADED WRITE-BUFFER ADDRESS location**.

DC Characteristics

CMOS Compatible

Parameter	Description	Test Conditions (Note: 1 & 2)	Min	Typ	Max	Unit
I_{LI}	Input Load Current	$V_{IN} = V_{SS}$ to V_{CC} , $V_{CC} = V_{CCmax}$			± 1	μA
I_{LO}	Output Leakage Current (Note 7)	$V_{OUT} = V_{SS}$ to V_{CC} , $V_{CC} = V_{CCmax}$			± 1	μA
I_{CCB}	V_{CC} Active burst Read Current	CE# = V_{IL} , OE# = V_{IH} , WE# = V_{IH} , burst length = 8	54 MHz	36	54	mA
			66 MHz	40	60	mA
		CE# = V_{IL} , OE# = V_{IH} , WE# = V_{IH} , burst length = 16	54 MHz	32	48	mA
			66 MHz	36	54	mA
		CE# = V_{IL} , OE# = V_{IH} , WE# = V_{IH} , burst length = 32	54 MHz	28	42	mA
			66 MHz	32	48	mA
CE# = V_{IL} , OE# = V_{IH} , WE# = V_{IH} , burst length = Continuous	54 MHz	24	36	mA		
	66 MHz	28	42	mA		
I_{IO1}	V_{IO} Non-active Output	OE# = V_{IH}		20	30	μA
I_{CC1}	V_{CC} Active Asynchronous Read Current (Note 3)	CE# = V_{IL} , OE# = V_{IH} , WE# = V_{IH}	10 MHz	30	36	mA
			5 MHz	15	18	mA
			1 MHz	3	4	mA
I_{CC2}	V_{CC} Active Write Current (Note 4)	CE# = V_{IL} , OE# = V_{IH} , ACC = V_{IH}	V_{ACC}	1	5	μA
			V_{CC}	<35	<52.5	mA
I_{CC3}	V_{CC} Standby Current (Note 5)	CE# = RESET# = $V_{CC} \pm 0.2 V$	V_{ACC}	1	5	μA
			V_{CC}	20	30	μA
I_{CC4}	V_{CC} Reset Current	RESET# = V_{IL} , CLK = V_{IL}		20	30	μA
I_{CC5}	V_{CC} Active Current (Read While Write)	CE# = V_{IL} , OE# = V_{IH} , ACC = V_{IH}		<50	<60	mA
I_{CC6}	V_{CC} Sleep Current	CE# = V_{IL} , OE# = V_{IH}		20	30	μA
I_{ACC}	Accelerated Program Current (Note 6)	CE# = V_{IL} , OE# = V_{IH} , $V_{ACC} = 9.5 V$	V_{ACC}	<30	<20	mA
			V_{CC}	<15	<20	mA
V_{IL}	Input Low Voltage	$V_{IO} = 1.8 V$	-0.5		0.4	V
V_{IH}	Input High Voltage	$V_{IO} = 1.8 V$	$V_{IO} - 0.4$		$V_{IO} + 0.4$	
V_{OL}	Output Low Voltage	$I_{OL} = 100 \mu A$, $V_{CC} = V_{CC min} = V_{IO}$			0.1	V
V_{OH}	Output High Voltage	$I_{OH} = -100 \mu A$, $V_{CC} = V_{CC min} = V_{IO}$	$V_{IO} - 0.1$			V
V_{HH}	Voltage for Accelerated Program		8.5		9.5	V
V_{LKO}	Low V_{CC} Lock-out Voltage		1.0		1.4	V

Note:

1. Maximum I_{CC} specifications are tested with $V_{CC} = V_{CCmax}$.
2. $V_{CC} = V_{IO}$
3. The I_{CC} current listed is typically less than 3 mA/MHz, with OE# at V_{IH} .
4. I_{CC} active while Embedded Erase or Embedded Program is in progress.
5. Device enters automatic sleep mode when addresses are stable for $t_{ACC} + 20ns$. Typical sleep mode current is equal to I_{CC3} .
6. Total current during accelerated programming is the sum of V_{ACC} and V_{CC} currents.
7. CE# must be set high when measuring the RDY pin.

Test Conditions

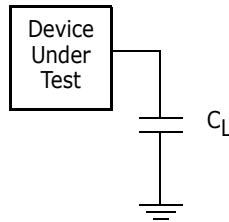

Figure 9. Test Setup

Table 21. Test Specifications

Test Condition	All Speed Options	Unit
Output Load Capacitance, C_L (including jig capacitance)	30	pF
Input Rise and Fall Times	3.0 @ 54, 66 MHz	ns
Input Pulse Levels	0.0– V_{IO}	V
Input timing measurement reference levels	$V_{IO}/2$	V
Output timing measurement reference levels	$V_{IO}/2$	V

Switching Waveforms

Table 22. Key to Switching Waveforms

WAVEFORM	INPUTS	OUTPUTS
	Steady	
	Changing from H to L	
	Changing from L to H	
	Don't Care, Any Change Permitted	Changing, State Unknown
	Does Not Apply	Center Line is High Impedance State (High Z)

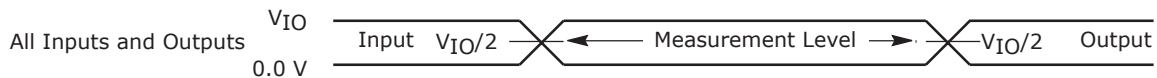

Figure 10. Input Waveforms and Measurement Levels

V_{CC} Power-up

Parameter	Description	Test Setup	Speed	Unit
t _{VCS}	V _{CC} Setup Time	Min	1	ms
t _{VIOS}	V _{I/O} Setup Time	Min	50	μs

Note:

1. V_{CC} ≥ V_{I/O} - 100mV and V_{CC} ramp rate is > 1V / 100μs
2. V_{CC} ramp rate < 1V / 100μs, a Hardware Reset will be required.

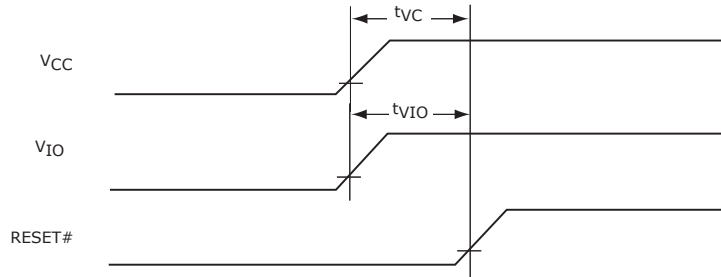

Figure II. V_{CC} Power-up Diagram

Pin Capacitance

Symbol	Parameter	Test Condition	Typ	Max	Unit
C _{IN1}	Input Capacitance	V _{IN} =0	4.2	5.0	pF
C _{IN2}	Output Capacitance	V _{out} =0	5.4	8.5	pF
C _{out}	Control Capacitance	V _{IN} =0	3.9	4.7	pF

AC Characteristics—Synchronous

CLK Characterization

Parameter	Description		54 MHz	66 MHz	Unit
f_{CLK}	CLK Frequency	Max	54	66	MHz
t_{CLK}	CLK Period	Min	18.5	15.1	ns
t_{CH}	CLK High Time	Min	7.4	6.1	ns
t_{CL}	CLK Low Time				
t_{CR}	CLK Rise Time	Max	3	3	ns
t_{CF}	CLK Fall Time				

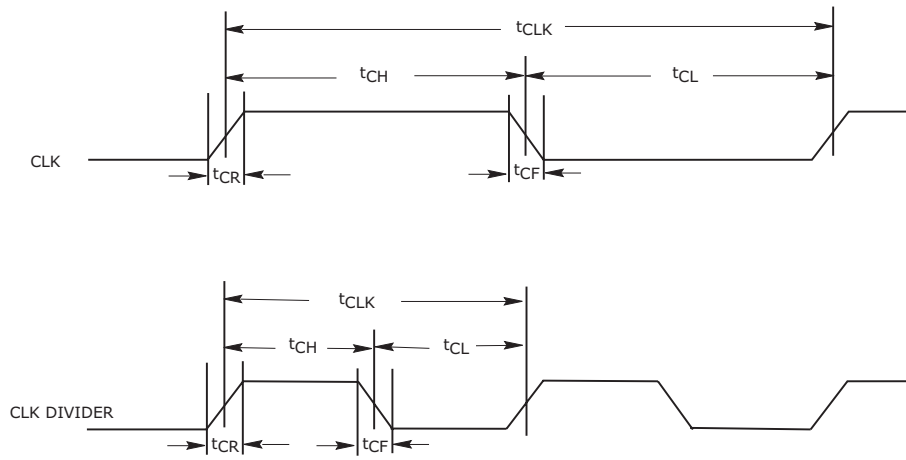

Figure I2. CLK Characterization

Synchronous/Burst Read @ $V_{IO} = 1.8\text{ V}$

Parameter		Description		54 MHz	66 MHz	Unit
JEDEC	Standard					
	t_{IACC}	Latency	Max	69		ns
	t_{BACC}	Burst Access Time Valid Clock to Output Delay	Max	13.5	11.2	ns
	t_{ACS}	Address Setup Time to CLK (Note 1)	Min	5	4	ns
	t_{ACH}	Address Hold Time from CLK (Note 1)	Min	7	6	ns
	t_{BDH}	Data Hold Time from Next Clock Cycle	Min	4	3	ns
	t_{CR}	Chip Enable to RDY Valid	Max	13.5	11.2	ns
	t_{OE}	Output Enable to Output Valid	Max	13.5	11.2	ns
	t_{CEZ}	Chip Enable to High Z	Max	10	8	ns
	t_{OEZ}	Output Enable to High Z	Max	10	8	ns
	t_{CES}	CE# Setup Time to CLK	Min	5	4	ns
	t_{RDYS}	RDY Setup Time to CLK	Min	5	4	ns
	t_{RACC}	Ready Access Time from CLK	Max	13.5	11.2	ns
	t_{AAS}	Address Setup Time to AVD# (Note 1)	Min	5	4	ns
	t_{AAH}	Address Hold Time to AVD# (Note 1)	Min	7	6	ns
	t_{CAS}	CE# Setup Time to AVD#	Min	0		ns
	t_{AVC}	AVD# Low to CLK	Min	5	4	ns
	t_{AVD}	AVD# Pulse	Min	12	10	ns
	t_{CKA}	CLK to access resume	Max	13.5	11.2	ns
	t_{CKZ}	CLK to High Z	Max	10	8	ns
	t_{OES}	Output Enable Setup Time	Min	5	4	ns
	t_{RCC}	Read cycle for continuous suspend	Max	1		ms

Notes:

1. Addresses are latched on the first of either the active edge of CLK or the rising edge of AVD#.
2. Clock Divider option

Timing Diagrams

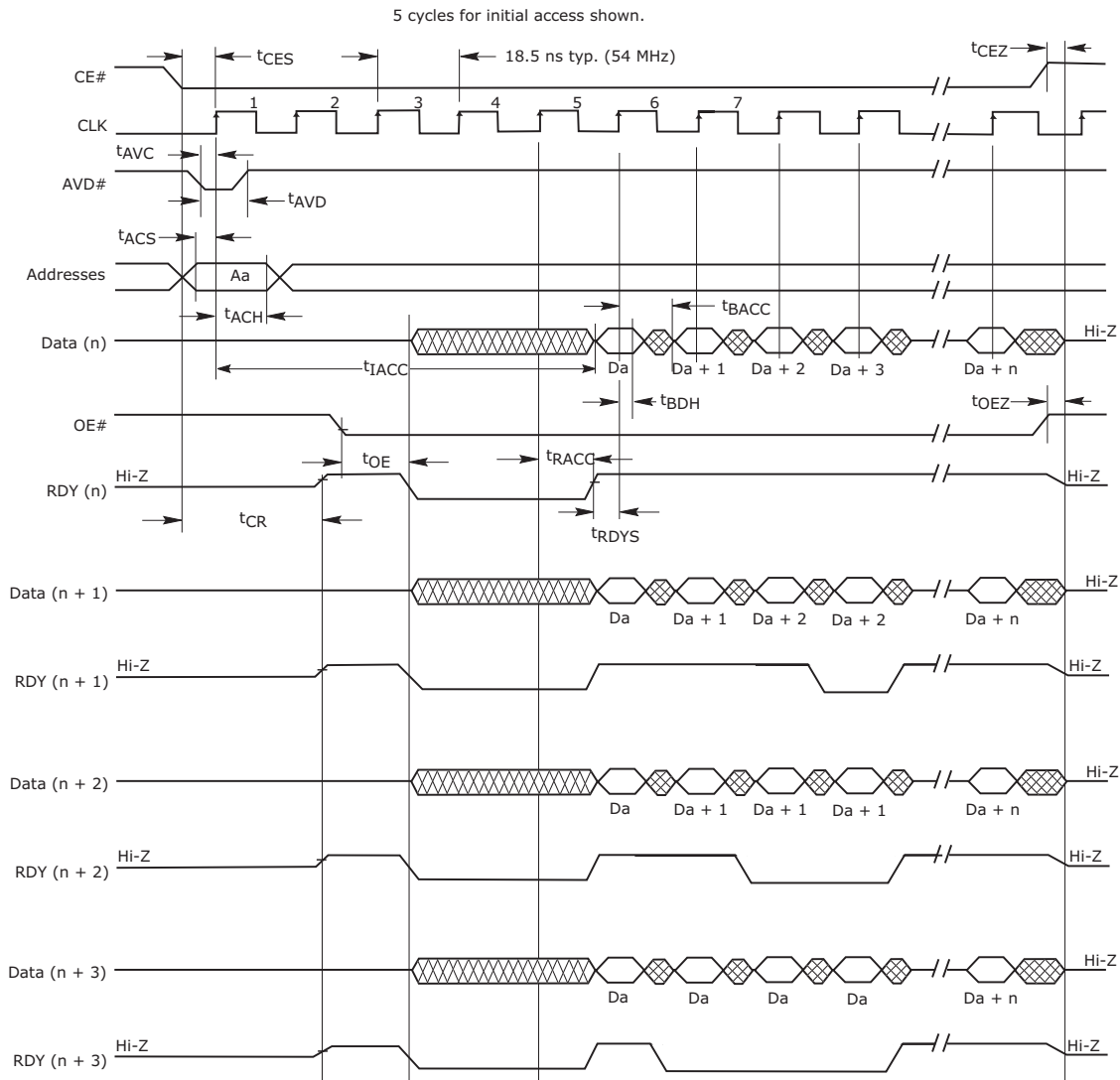

Notes:

1. Figure shows total number of wait states set to five cycles. The total number of wait states can be programmed from two cycles to seven cycles.
2. If any burst address occurs at "address + 1", "address + 2", or "address + 3", additional clock delay cycles are inserted, and are indicated by RDY.
3. The device is in synchronous mode.

Figure I3. CLK Synchronous Burst Mode Read (rising active CLK)

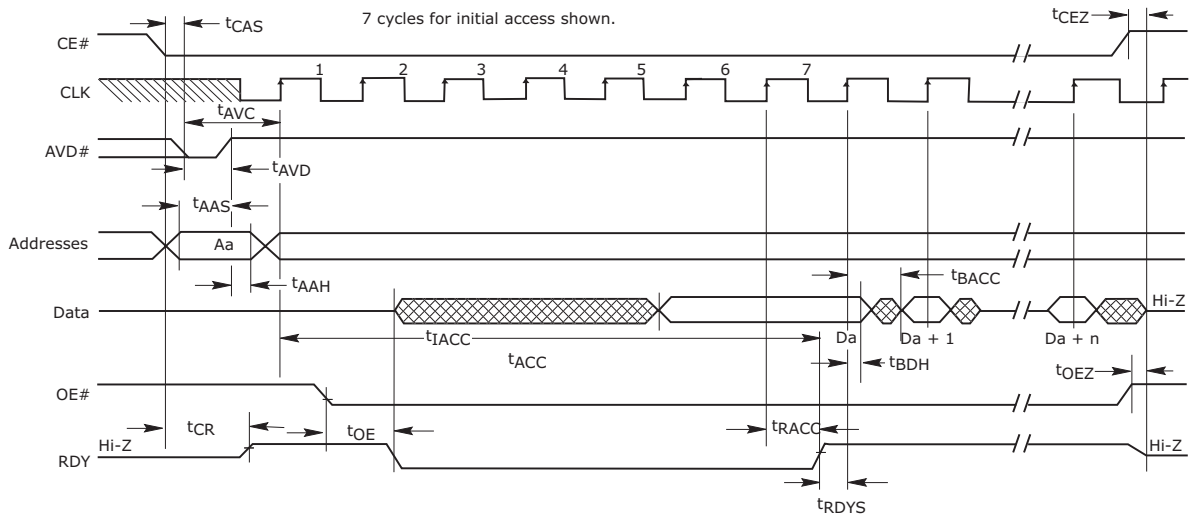

Notes:

1. Figure shows total number of wait states set to seven cycles. The total number of wait states can be programmed from two cycles to seven cycles. Clock is set for active rising edge.
2. If any burst address occurs at "address + 1", "address + 2", or "address + 3", additional clock delay cycles are inserted, and are indicated by RDY.
3. The device is in synchronous mode.

Figure I4. Synchronous Burst Mode Read

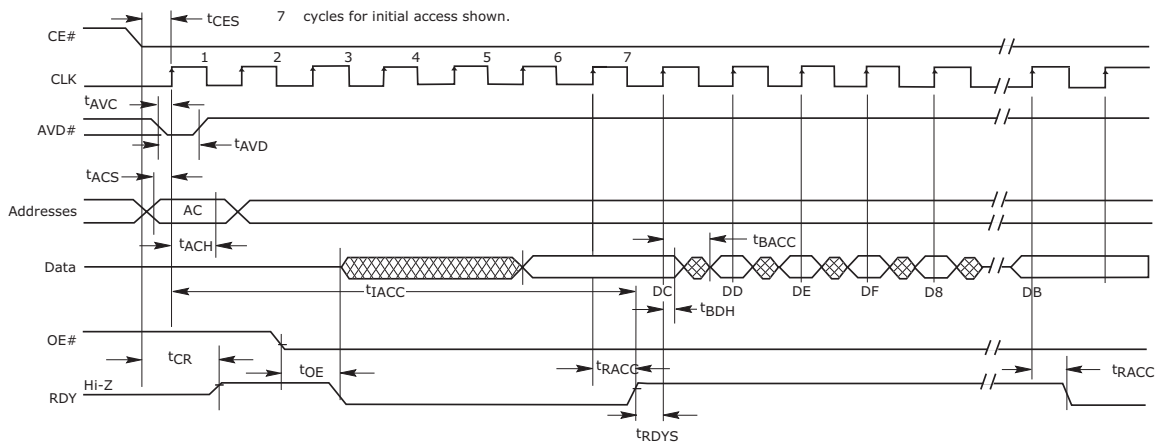

Notes:

1. Figure shows total number of wait states set to seven cycles. The total number of wait states can be programmed from two cycles to seven cycles. Clock is set for active rising edge.
2. If any burst address occurs at "address + 1", "address + 2", or "address + 3", additional clock delay cycles are inserted, and are indicated by RDY.
3. The device is in synchronous mode with wrap around.
4. DQ0-DQ7 in data waveform indicate the order of data within a given 8-word address range, from lowest to highest. Starting address in figure is the 4th address in range (AC).

Figure I5. Eight-word Linear Burst with Wrap Around

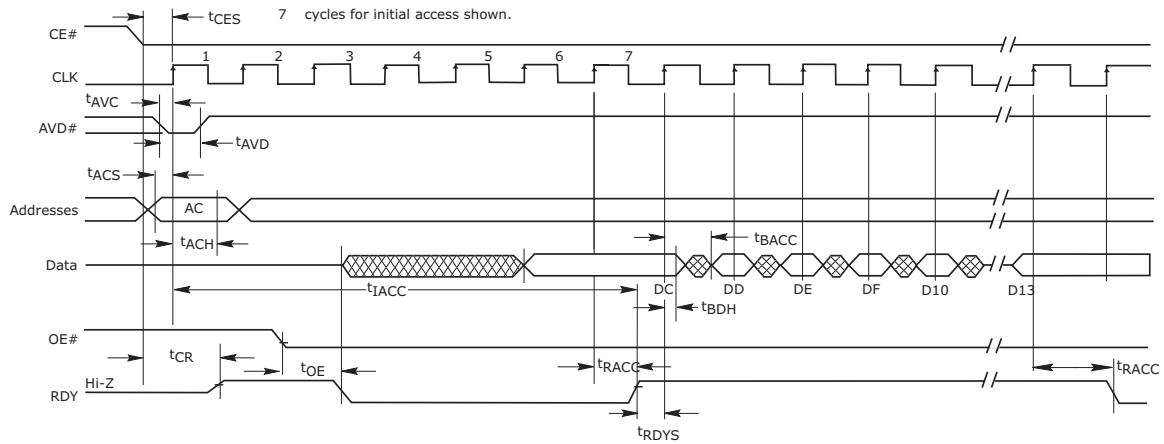

Notes:

1. Figure shows total number of wait states set to seven cycles. The total number of wait states can be programmed from two cycles to seven cycles. Clock is set for active rising edge.
2. If any burst address occurs at "address + 1", "address + 2", or "address + 3", additional clock delay cycles are inserted, and are indicated by RDY.
3. The device is in asynchronous mode with out wrap around.
4. DQ-DQ7 in data waveform indicate the order of data within a given 8-word address range, from lowest to highest. Starting address in figure is the 4th address in range (AC).

Figure 16. Eight-word Linear Burst without Wrap Around

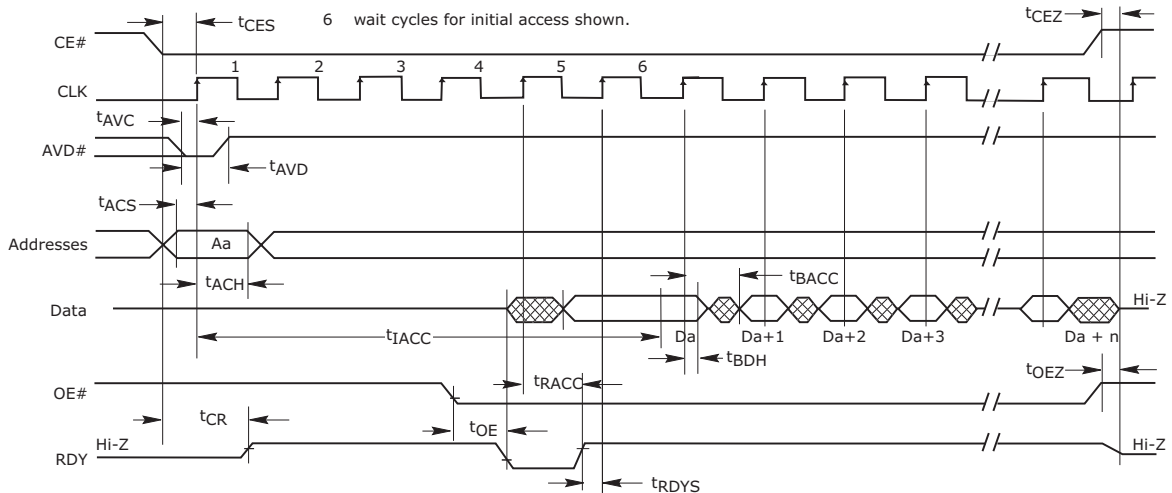

Notes:

1. Figure assumes 6 wait states for initial access and synchronous read.
2. The Set Configuration Register command sequence has been written with CR8=0; device will output RDY one cycle before valid data.

Figure 17. Linear Burst with RDY Set One Cycle Before Data

AC Characteristics—Asynchronous

Asynchronous Mode Read @ $V_{IOP5} = 1.8\text{ V}$

Parameter		Description		54 MHz	66 MHz	Unit
JEDEC	Standard					
	t_{CE}	Access Time from CE# Low	Max	70	70	ns
	t_{ACC}	Asynchronous Access Time (Note 1)	Max	70	70	ns
	t_{AVDP}	AVD# Low Time	Min	12	10	ns
	t_{AAVDS}	Address Setup Time to Rising Edge of AVD#	Min	5	4	ns
	t_{AAVDH}	Address Hold Time from Rising Edge of AVD#	Min	7	6	ns
	t_{OE}	Output Enable to Output Valid	Max	13.5	11.2	ns
	t_{OEH}	Output Enable Hold Time	Read	0		ns
			Toggle and Data# Polling	Min	10	8
	t_{OEZ}	Output Enable to High Z (Note 2)	Max	10	8	ns
	t_{CAS}	CE# Setup Time to AVD#	Min	0		ns

Notes:

1. Asynchronous Access Time is from the last of either stable addresses or the falling edge of AVD#.
2. Not 100% tested.

Timing Diagrams

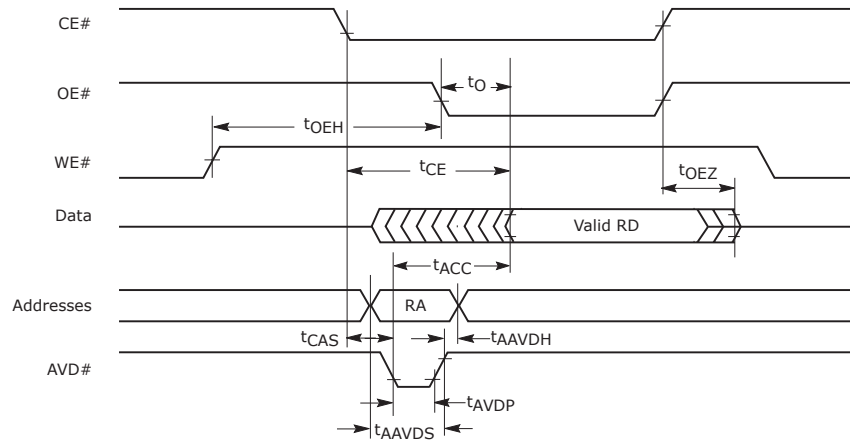

Note: RA = Read Address, RD = Read Data.

Figure 18. Asynchronous Mode Read with Latched Addresses

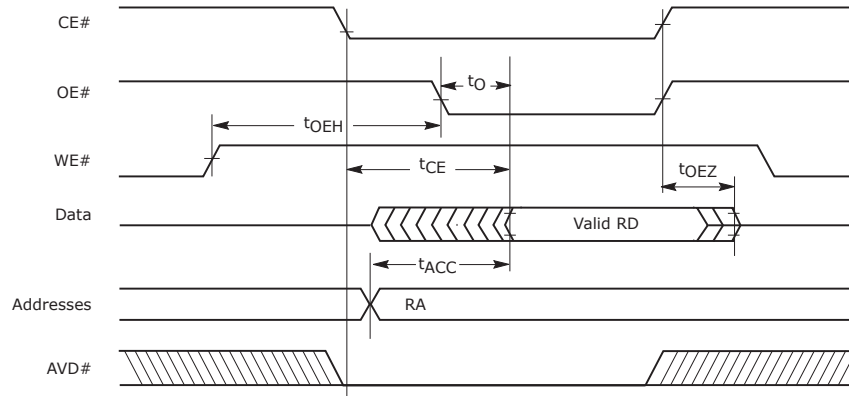

Note: RA = Read Address, RD = Read Data.

Figure 19. Asynchronous Mode Read

Hardware Reset (RESET#)

Parameter		Description		All Speed Options	Unit
JEDEC	Std				
	t_{RP}	RESET# Pulse Width	Min	1	ms
	t_{RH}	Reset High Time Before Read (During Embedded Algorithms) to Read Mode (See Note)	Min	30	μ s
		Reset High Time Before Read (NOT During Embedded Algorithms) to Read Mode (See Note)			

Note: Not 100% tested.

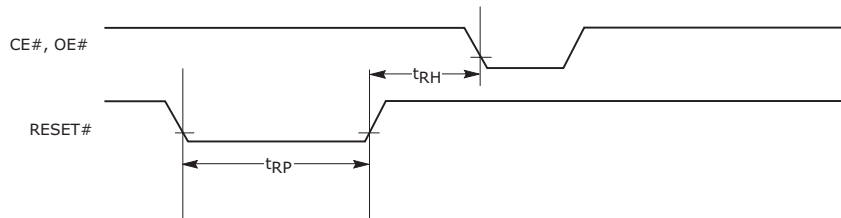

Figure 20. Reset Timings

Erase/Program Operations @ $V_{IO} = 1.8\text{ V}$

Parameter		Description		54 MHz	66 MHz	Unit
JEDEC	Standard			54 MHz	66 MHz	
t_{AVAV}	t_{WC}	Write Cycle Time (Note 1)	Min	70	70	ns
t_{AVWL}	t_{AS}	Address Setup Time (Notes 2, 3)	Synchronous	5	4	ns
			Asynchronous	0		
t_{WLAX}	t_{AH}	Address Hold Time (Notes 2, 3)	Synchronous	7	6	ns
			Asynchronous	20		
	t_{AVDP}	AVD# Low Time	Min	12	10	ns
t_{DVWH}	t_{DS}	Data Setup Time	Min	45	20	ns
t_{WHDX}	t_{DH}	Data Hold Time	Min	0		ns
t_{GHWL}	t_{GHWL}	Read Recovery Time Before Write	Min	0		ns
	t_{CAS}	CE# Setup Time to AVD#	Min	0		ns
t_{WHEH}	t_{CH}	CE# Hold Time	Min	0		ns
t_{WLWH}	t_{WP}	Write Pulse Width	Min	30	25	ns
t_{WHWL}	t_{WPH}	Write Pulse Width High	Min	20		ns
	$t_{SR/W}$	Latency Between Read and Write Operations	Min	0		ns
t_{WHWH1}	t_{WHWH1}	Programming Operation (Note 4)	Typ	<9.4		μs
t_{WHWH1}	t_{WHWH1}	Accelerated Programming Operation (Note 4)	Typ	<4		μs
t_{WHWH2}	t_{WHWH2}	Sector Erase Operation (Notes 4, 5)	Typ	0.4		sec
		Chip Erase Operation (Notes 4, 5)		<104 (WS256N)		
	t_{VID}	V_{ACC} Rise and Fall Time	Min	500		ns
	t_{VIDS}	V_{ACC} Setup Time (During Accelerated Programming)	Min	1		μs
	t_{VCS}	V_{CC} Setup Time	Min	50		μs
t_{ELWL}	t_{CS}	CE# Setup Time to WE#	Min	5	4	ns
	t_{AVSW}	AVD# Setup Time to WE#	Min	5	4	ns
	t_{AVHW}	AVD# Hold Time to WE#	Min	5	4	ns
	t_{AVSC}	AVD# Setup Time to CLK	Min	5	4	ns
	t_{AVHC}	AVD# Hold Time to CLK	Min	5	4	ns
	t_{CSW}	Clock Setup Time to WE#	Min	5		ns

Notes:

1. Not 100% tested.
2. Asynchronous read mode allows Asynchronous program operation only. Synchronous read mode allows both Asynchronous and Synchronous program operation.
3. In asynchronous program operation timing, addresses are latched on the falling edge of WE#. In synchronous program operation timing, addresses are latched on the active edge of CLK or rising edge of AVD#.
4. See the "Erase and Programming Performance" section for more information.
5. Does not include the preprogramming time.

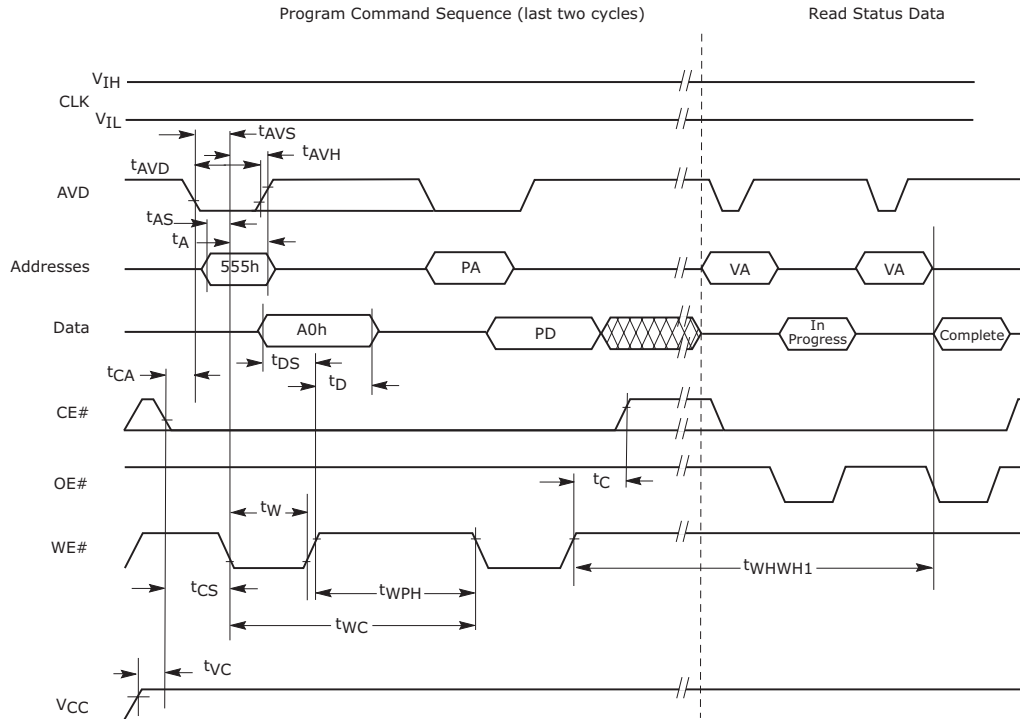

Notes:

1. PA = Program Address, PD = Program Data, VA = Valid Address for reading status bits.
2. "In progress" and "complete" refer to status of program operation.
3. A23-A14 for the WS256N are don't care during command sequence unlock cycles.
4. CLK can be either V_{IL} or V_{IH}.
5. The Asynchronous programming operation is independent of the Set Device Read Mode bit in the Configuration Register.

Figure 21. Asynchronous Program Operation Timings: WE# Latched Addresses

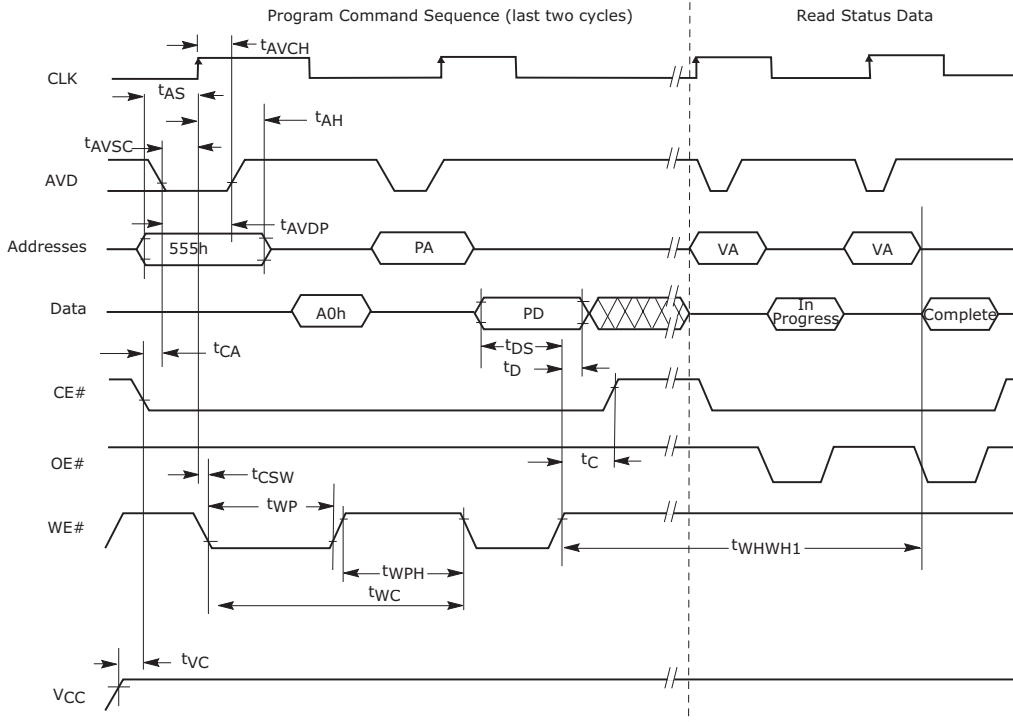

Notes:

1. PA = Program Address, PD = Program Data, VA = Valid Address for reading status bits.
2. "In progress" and "complete" refer to status of program operation.
3. A23-A14 for the WS256N are don't care during command sequence unlock cycles.
4. Addresses are latched on the first of either the rising edge of AVD# or the active edge of CLK.
5. Either CE# or AVD# is required to go from low to high in between programming command sequences.
6. The Synchronous programming operation is dependent of the Set Device Read Mode bit in the Configuration Register. The Configuration Register must be set to the Synchronous Read Mode.

Figure 22. Synchronous Program Operation Timings: CLK Latched Addresses

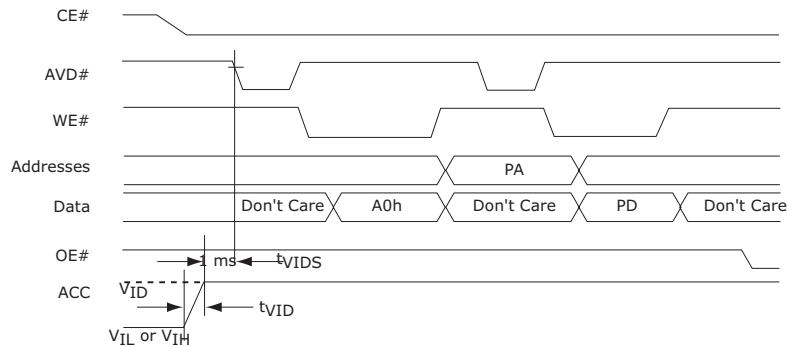

Note: Use setup and hold times from conventional program operation.

Figure 23. Accelerated Unlock Bypass Programming Timing

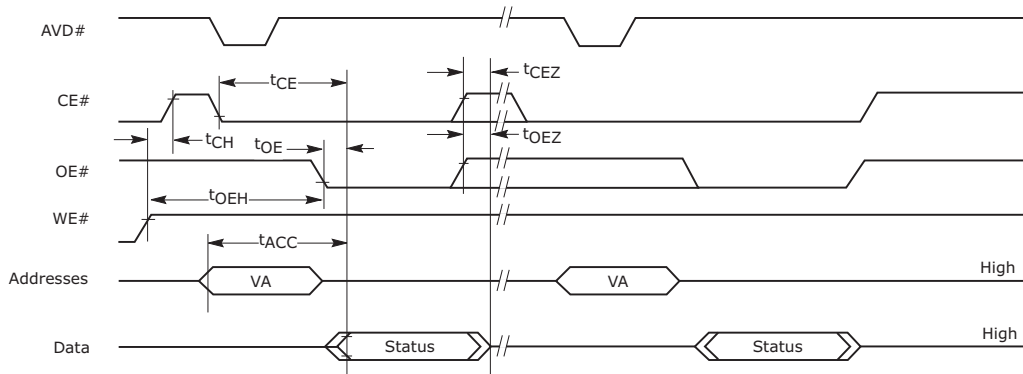

Notes:

1. Status reads in figure are shown as asynchronous.
2. VA = Valid Address. Two read cycles are required to determine status. When the Embedded Algorithm operation is complete, and Data# Polling will output true data.

Figure 24. Data# Polling Timings (During Embedded Algorithm)

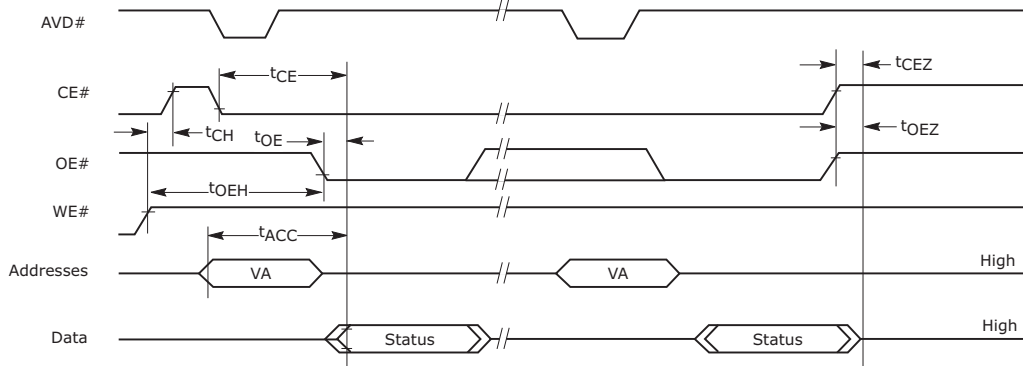

Notes:

1. Status reads in figure are shown as asynchronous.
2. VA = Valid Address. Two read cycles are required to determine status. When the Embedded Algorithm operation is complete, the toggle bits will stop toggling.

Figure 25. Toggle Bit Timings (During Embedded Algorithm)

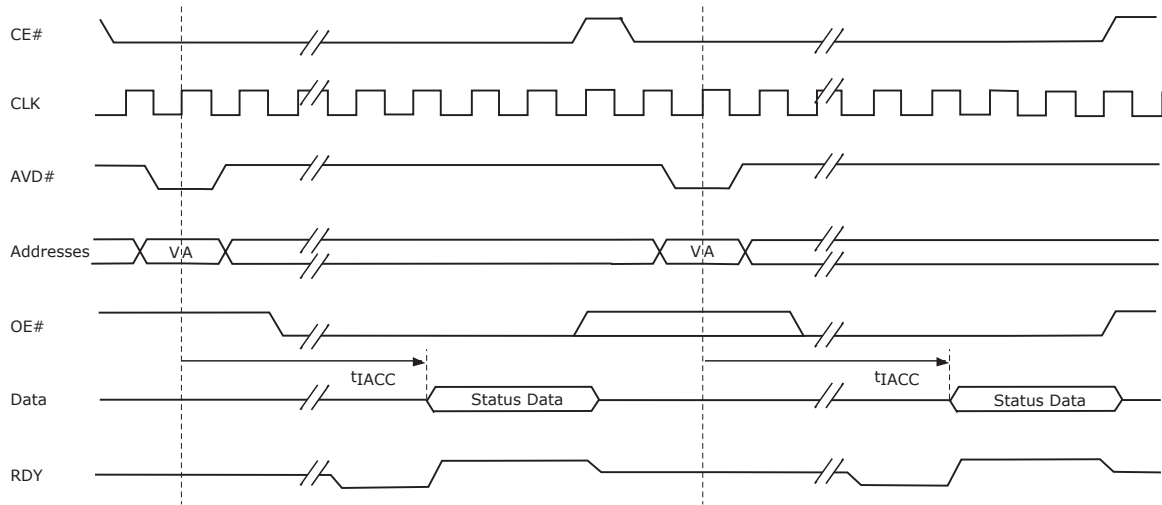

Notes:

1. The timings are similar to synchronous read timings.
2. VA = Valid Address. Two read cycles are required to determine status. When the Embedded Algorithm operation is complete, the toggle bits will stop toggling.
3. RDY is active with data (DQ8 = 0 in the Configuration Register). When DQ8 = 1 in the Configuration Register, RDY is active one clock cycle before data.

Figure 26. Synchronous Data Polling Timings/Toggle Bit Timings

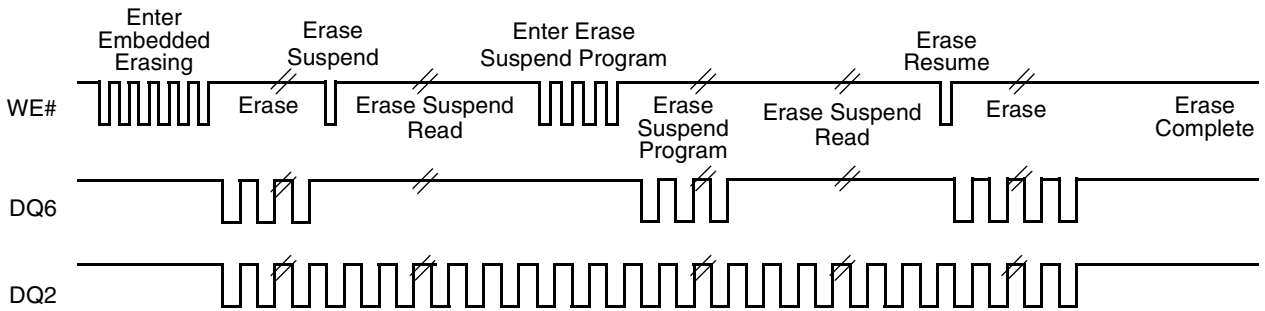

Note: DQ2 toggles only when read at an address within an erase-suspended sector. The system may use OE# or CE# to toggle DQ2 and DQ6

Figure 27. DQ2 vs. DQ6

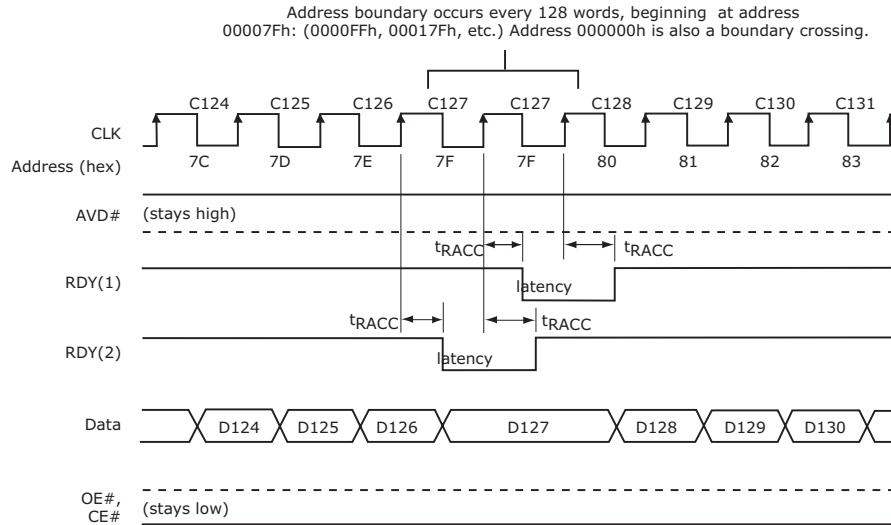

Notes:

1. RDY active with data (DQ8 = 0 in the Configuration Register).
2. RDY active one clock cycle before data (DQ8 = 1 in the Configuration Register).
3. Cxx indicates the clock that triggers Dxx on the outputs; for example, C60 triggers D60.
4. Figure shows the device not crossing a bank in the process of performing an erase or program.
5. RDY will not go low and no additional wait states will be required if the Burst frequency is ≤ 66 MHz and the Boundary Crossing bit (DQ14) in the Configuration Register is set to 0

Figure 28. Latency with Boundary Crossing when Frequency > 66 MHz

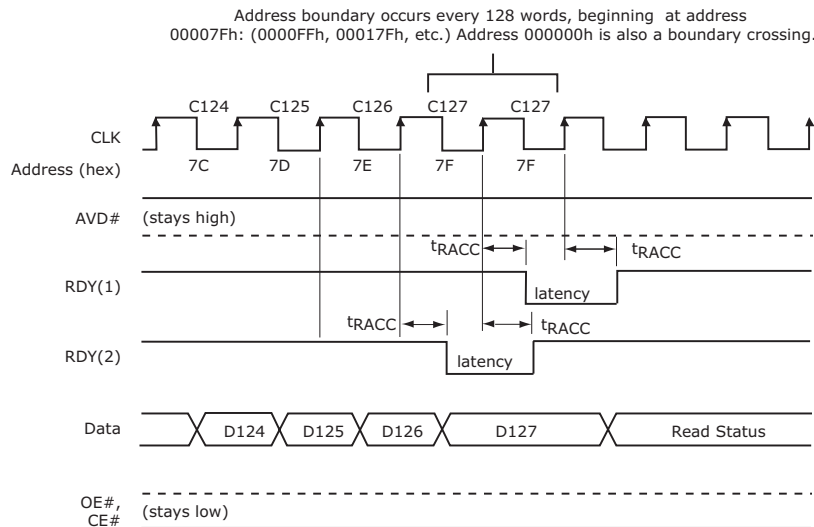

Notes:

1. RDY active with data (DQ8 = 0 in the Configuration Register).
2. RDY active one clock cycle before data (DQ8 = 1 in the Configuration Register).
3. Cxx indicates the clock that triggers Dxx on the outputs; for example, C60 triggers D60.
4. Figure shows the device crossing a bank in the process of performing an erase or program.
5. RDY will not go low and no additional wait states will be required if the Burst frequency is ≤ 66 MHz and the Boundary Crossing bit (DQ14) in the Configuration Register is set to 0

Figure 29. Latency with Boundary Crossing into Program/Erase Bank

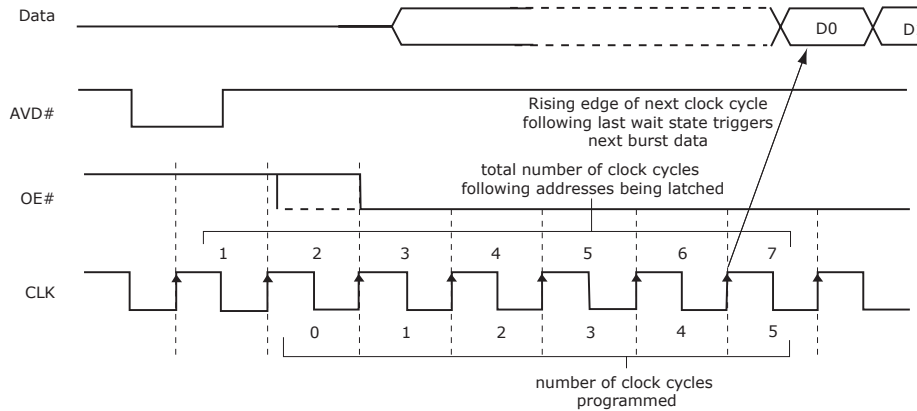

Wait State Configuration Register Setup:

- DQ13, DQ12, DQ11 = "111" ⇒ Reserved
- DQ13, DQ12, DQ11 = "110" ⇒ Reserved
- DQ13, DQ12, DQ11 = "101" ⇒ 5 programmed, 7 total
- DQ13, DQ12, DQ11 = "100" ⇒ 4 programmed, 6 total
- DQ13, DQ12, DQ11 = "011" ⇒ 3 programmed, 5 total
- DQ13, DQ12, DQ11 = "010" ⇒ 2 programmed, 4 total
- DQ13, DQ12, DQ11 = "001" ⇒ 1 programmed, 3 total
- DQ13, DQ12, DQ11 = "000" ⇒ 0 programmed, 2 total

Note: Figure assumes address DQ0 is not at an address boundary, active clock edge is rising, and wait state is set to "101".

Figure 30. Example of Wait States Insertion

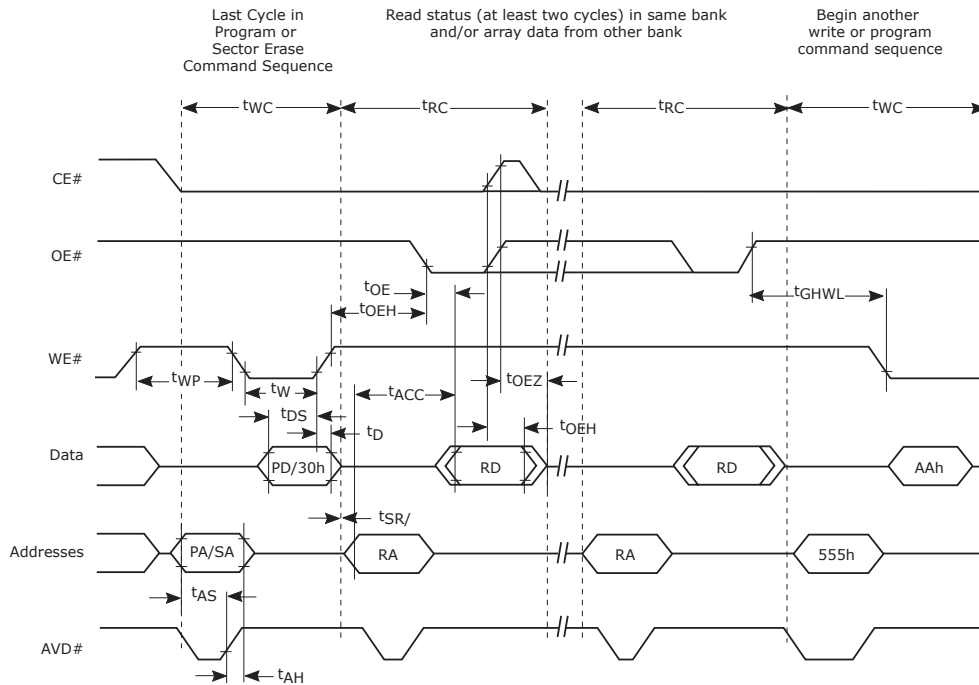

Note: Breakpoints in waveforms indicate that system may alternately read array data from the "non-busy bank" while checking the status of the program or erase operation in the "busy" bank. The system should read status twice to ensure valid information.

Figure 31. Back-to-Back Read/Write Cycle Timings

Erase and Programming Performance

Parameter			Typ (Note 1)	Max (Note 2)	Unit	Comments
Sector Erase Time	64 Kword	VCC	<0.4	2.5	s	Excludes 00h programming prior to erasure (Note 4)
	16 Kword	VCC	<0.15	2		
Chip Erase Time		VCC	<104 (WS256N)	<208 (WS256N)	s	
		ACC	<86.7(WS256N)	<173.4 (WS256N)		
Effective Word Programming Time utilizing Program Write Buffer		VCC	<9.4	<18.8	μs	
		ACC	<4	<8		
Total 32-Word Buffer Programming Time		VCC	<300	<600	μs	
		ACC	<64	<128		
Chip Programming Time (Note 3)		VCC	<335.5 (WS256N)	<671 (WS256N)	s	Excludes system level overhead (Note 5)
		ACC	<145.9 (WS256N)	<292 (WS256N)		
Erase Suspend/Erase Resume				<20	μs	
Program Suspend/Program Resume				<20	μs	

Notes:

1. Typical program and erase times assume the following conditions: 25°C, 1.8 V V_{CC} , 10,000 cycles; checkerboard data pattern.
2. Under worst case conditions of 90°C, $V_{CC} = 1.65$ V, 100,000 cycles.
3. The typical chip programming time is considerably less than the maximum chip programming time listed. Based upon single word programming, not page programming.
4. In the pre-programming step of the Embedded Erase algorithm, all words are programmed to 00h before erasure.
5. System-level overhead is the time required to execute the two- or four-bus-cycle sequence for the program command. See the "[Command Definition Summary](#)" section for further information on command definitions.
6. Contact the local sales office for minimum cycling endurance values in specific applications and operating conditions.

I28Mb pSRAM

(8M word x 16 bit) Pseudo SRAM with Page & Burst

FEATURES

- Fast Access Cycle Time
 $t_{CE} = 70\text{ns max}$
- 8 words Page Read Access Capability
 $t_{PAA} = 20\text{ns max}$
- Burst Read/Write Access Capability
 $t_{AC} = 11\text{ns max}$
- Low Voltage Operating Condition
 $V_{DD} = +2.6 \text{ to } +3.1\text{V}$
- $V_{DDQ} = +1.65\text{V to } +1.95\text{V}$

- Wide Operating Temperature
 $T_A = -30^\circ\text{C to } +85^\circ\text{C}$
- Byte Control by UB# and $\bar{\text{LB}}\#$
- Low Power Consumption
 $I_{DDA1} = 35\text{mA max}$
 $I_{DDS1} = 300 \text{ mA max}$
- Various Power Down mode
Sleep, 16M-bit and 32M-bit Partial

FUNCTION TRUTH TABLE

Asynchronous Operation (Page Mode)









Mode	Note	CE2pS2	CE#1pS	CLK	ADV#	WE#	OE#	LB#	UB#	A22-0	DQ0-7	DQ8-15	RDY
Standby (Deselect)		H	H	X	X	X	X	X	X	X	High-Z	High-Z	High-Z
Output Disable	*1	H	L	X	*3	H	H	X	X	*5	High-Z	High-Z	High-Z
Output Disable (No Read)	X			*3			H	H	Valid	High-Z	High-Z	High-Z	
Read (Upper Byte)	X			*3			H	L	Valid	High-Z	Output Valid	High-Z	
Read (Lower Byte)	X			*3	H	L	L	H	Valid	Output Valid	High-Z	High-Z	
Read (Word)	X			*3			L	L	Valid	Output Valid	Output Valid	High-Z	
Page Read	X			*3			L/H	L/H	Valid	*6	*6	High-Z	
No Write	X			*3			H	H	Valid	Invalid	Invalid	High-Z	
Write (Upper Byte)	X			*3	L	H	H	L	Valid	Invalid	Input Valid	High-Z	
Write (Lower Byte)	X			*3			L	H	Valid	Input Valid	Invalid	High-Z	
Write (Word)	X			*3			L	L	Valid	Input Valid	Input Valid	High-Z	
Power Down	*2			L	X	X	X	X	X	X	X	X	High-Z



Note: L = V_{IL} , H = V_{IH} , X can be either V_{IL} or V_{IH} , High-Z = High Impedance

- *1: Should not be kept this logic condition longer than 1ms.
Please contact local FUJITSU representative for the relaxation of 1ms limitation.
- *2: Power Down mode can be entered from Standby state and all DQ pins are in High-Z state.
Data retention depends on the selection of Partial Size.
Refer to "Power Down" in FUNCTIONAL DESCRIPTION for the details.
- *3: "L" for address pass through and "H" for address latch on the rising edge of ADV#.
- *4: OE# can be V_{IL} during Write operation if the following conditions are satisfied;
(1) Write pulse is initiated by CE#1 (refer to CE#1 Controlled Write timing), or cycle time of the previous operation cycle is satisfied.
(2) OE# stays V_{IL} during Write cycle.
- *5: Can be either V_{IL} or V_{IH} but must be valid before Read or Write.
- *6: Output is either Valid or High-Z depending on the level of UB# and LB# input.

FUNCTION TRUTH TABLE (Continued)

Synchronous Operation (Burst Mode)

Mode	Note	CE2	CE#1	CLK	ADV#	WE#	OE#	LB#	UB#	A22-0	DQ8-1	DQ16-9	WAIT#
Standby (Deselect)			H	X	X	X	X	X	X	X	High-Z	High-Z	High-Z
Start Address Latch	*1					*4 X	*4 X			*7 Valid	*8 High-Z	*8 High-Z	*11 High-Z
Advance Burst Read to Next Address	*1					H	L				*9 Output Valid	*9 Output Valid	Output Valid
Burst Read Suspend	*1		L				H				High-Z	High-Z	*12 High
Advance Burst Write to Next Address	*1				H	*5 L	H			X	*10 Input Valid	*10 Input Valid	*13 High
Burst Write Suspend	*1					*5 H		*6 X	*6 X		Input Invalid	Input Invalid	*12 High
Terminate Burst Read				X		H	X				High-Z	High-Z	High-Z
Terminate Burst Write				X		X	H				High-Z	High-Z	High-Z
Power Down	*2	L	X	X	X	X	X	X	X	X	High-Z	High-Z	High-Z

Notes: L = V_{IL} , H = V_{IH} , X can be either V_{IL} or V_{IH} ,  = valid edge,  = positive edge of Low pulse, High-Z = High Impedance

- *1: Should not be kept this logic condition longer than 4ms. Please contact local FUJITSU representative for the relaxation of 4ms limitation.
- *2: Power Down mode can be entered from Standby state and all DQ pins are in High-Z state. Data retention depends on the selection of Partial Size. Refer to "Power Down" in FUNCTIONAL DESCRIPTION for the details.
- *3: Valid clock edge shall be set on either positive or negative edge through CR Set. CLK must be started and stable prior to memory access.
- *4: Can be either V_{IL} or V_{IH} except for the case the both of OE# and WE# are V_{IL} . It is prohibited to bring the both of OE# and WE# to V_{IL} .
- *5: When device is operating in "WE# Single Clock Pulse Control" mode, WE# is don't care once write operation is determined by WE# Low Pulse at the beginning of write access together with address latching. Write suspend feature is not supported in "WE# Single Clock Pulse Control" mode
- *6: Can be either V_{IL} or V_{IH} but must be valid before Read or Write is determined. And once UB# and LB# inputs are determined, they must not be changed until the end of burst.
- *7: Once valid address is determined, input address must not be changed during ADV#=L.
- *8: If OE#=L, output is either Invalid or High-Z depending on the level of UB# and LB# input. If WE#=L, Input is Invalid. If OE#=WE#=H, output is High-Z.
- *9: Output is either Valid or High-Z depending on the level of UB# and LB# input.
- *10: Input is either Valid or Invalid depending on the level of UB# and LB# input.
- *11: Output is either High-Z or Invalid depending on the level of OE# and WE# input.
- *12: Keep the level from previous cycle except for suspending on last data. Refer to "WAIT# Output Function" in FUNCTIONAL DESCRIPTION for the details.
- *13: WAIT# output is driven in High level during write operation.

STATE DIAGRAM

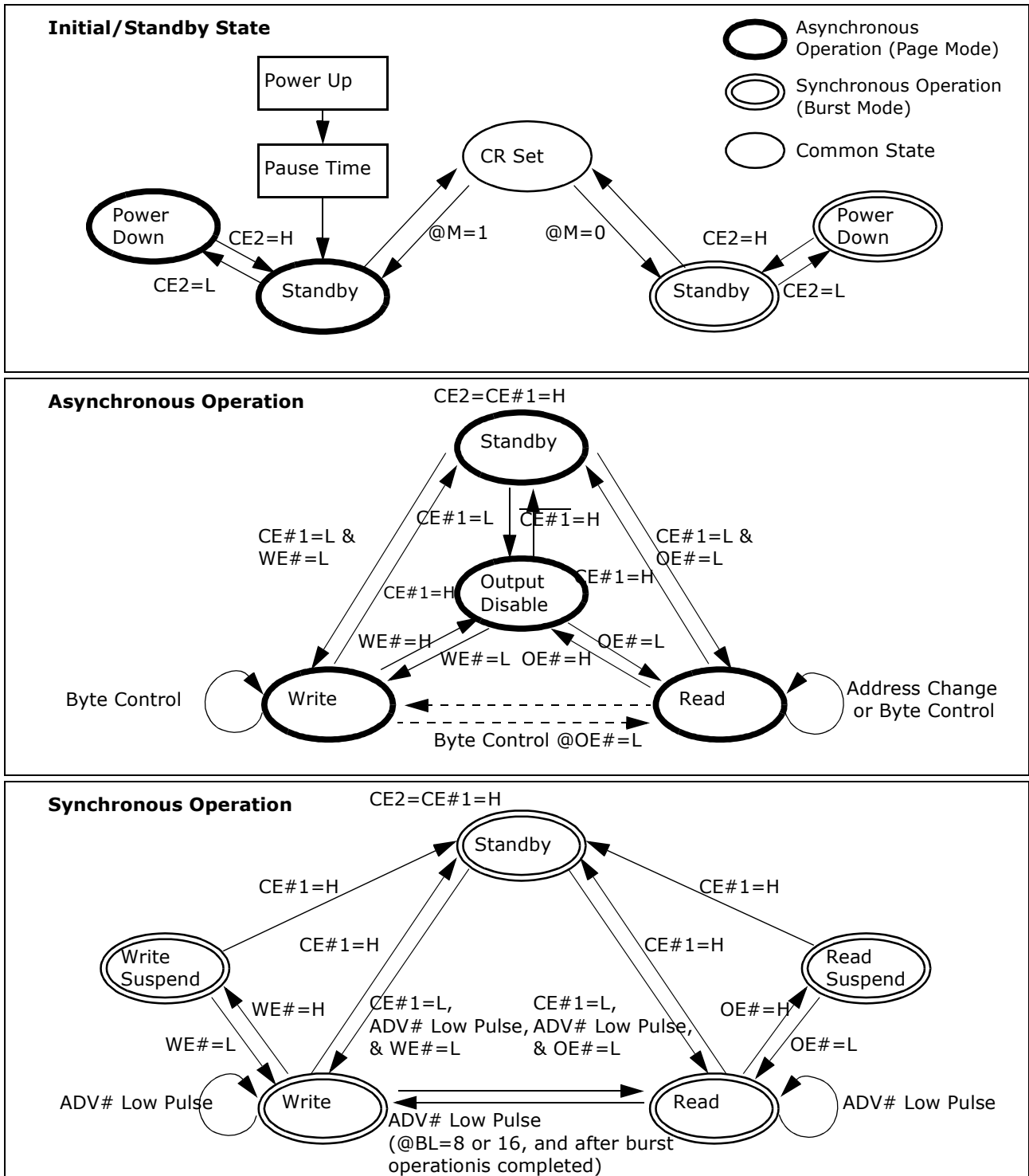

Note: Assuming all the parameters specified in AC CHARACTERISTICS are satisfied. Refer to the FUNCTIONAL DESCRIPTION, AC CHARACTERISTICS, and TIMING DIAGRAM for details.

FUNCTIONAL DESCRIPTION

This device supports asynchronous page read & normal write operation and synchronous burst read & burst write operation for faster memory access and features three kinds of power down modes for power saving as user configurable option.

Power-up

It is required to follow the power-up timing to start executing proper device operation. Refer to POWER-UP Timing. After Power-up, the device defaults to asynchronous page read & normal write operation mode with sleep power down feature.

Configuration Register

The Configuration Register (CR) is used to configure the type of device function among optional features. Each selection of features is set through CR Set sequence after Power-up. If CR Set sequence is not performed after power-up, the device is configured for asynchronous operation with sleep power down feature as default configuration

CR Set Sequence

The CR Set requires total 6 read/write operation with unique address. Between each read/write operation requires that device being in standby mode. Following table shows the detail sequence.

Cycle #	Operation	Address	Data
1st	Read	7FFFFh (MSB)	Read Data (RDa)
2nd	Write	7FFFFh	RDa
3rd	Write	7FFFFh	RDa
4th	Write	7FFFFh	X
5th	Write	7FFFFh	X
6th	Read	Address Key	Read Data (RDb)

The first cycle is to read from most significant address (MSB).

The second and third cycle are to write back the data (RDa) read by first cycle. If the second or third cycle is written into the different address, the CR Set is cancelled and the data written by the second or third cycle is valid as a normal write operation.

The fourth and fifth cycle is to write to MSB. The data of fourth and fifth cycle is don't-care. If the fourth or fifth cycle is written into different address, the CR Set is also cancelled but write data may not be written as normal write operation.

The last cycle is to read from specific address key for mode selection. And read data (RDb) is invalid.

Once this CR Set sequence is performed from an initial CR set to the other new CR set, the written data stored in memory cell array may be lost. So, it should perform the CR Set sequence prior to regular read/write operation if necessary to change from default configuration.

FUNCTIONAL DESCRIPTION (Continued)

Address Key

The address key has the following format.

Address Pin	Register Name	Function	Key	Description	Note
A22-A21	—	—	1	Unused bits must be 1	*1
A20-A19	PS	Partial Size	00	32M Partial	
			01	16M Partial	
			10	Reserved for future use	*2
			11	Sleep [Default]	
A18-A16	BL	Burst Length	000	Reserved for future use	*2
			001	Reserved for future use	*2
			010	8 words	
			011	16 words	
			100	Reserved for future use	*2
			101	Reserved for future use	*2
			110	Reserved for future use	*2
			111	Continuous	
A15	M	Mode	0	Synchronous Mode (Burst Read / Write)	*3
			1	Asynchronous Mode[Default] (Page Read / Normal Write)	*4
A14-A12	RL	Read Latency	000	Reserved for future use	*2
			001	3 clocks	
			010	4 clocks	
			011	5 clocks	
			1xx	Reserved for future use	*2
A11	BS	Burst Sequence	0	Reserved for future use	*2
			1	Sequential	
A10	SW	Single Write	0	Burst Read & Burst Write	
			1	Burst Read & Single Write	*5
A9	VE	Valid Clock Edge	0	Falling Clock Edge	
			1	Rising Clock Edge	
A8	—	—	1	Unused bits must be 1	*1
A7	WC	Write Control	0	WE# Single Clock Pulse Control without Write Suspend Function	*5
			1	WE# Level Control with Write Suspend Function	
A6-A0	—	—	1	Unused bits must be 1	*1

Notes *1: A22, A21, A8, and A6 to A0 must be all "1" in any cases.

*2: It is prohibited to apply this key.

*3: If M=0, all the registers must be set with appropriate Key input at the same time.

*4: If M=1, PS must be set with appropriate Key input at the same time. Except for PS, all the other key inputs must be "1".

*5: Burst Read & Single Write is not supported at WE# Single Clock Pulse Control.

FUNCTIONAL DESCRIPTION (Continued)

Power Down

The Power Down is low power idle state controlled by CE2. CE2 Low drives the device in power down mode and mains low power idle state as long as CE2 is kept low. CE2 High resume the device from power down mode.

This device has three power down modes, Sleep, 16M Partial, and 32M Partial. The selection of power down mode is set through CR Set sequence. Each mode has following data retention features.

Mode	Data Retention Size	Retention Address
Sleep [default]	No	N/A
16M Partial	16M bit	000000h to 0FFFFFFh
32M Partial	32M bit	000000h to 1FFFFFFh

The default state is Sleep and it is the lowest power consumption but all data will be lost once CE2 is brought to Low for Power Down. It is not required to perform CR Set sequence to set to Sleep mode after power-up in case of asynchronous operation.

FUNCTIONAL DESCRIPTION (Continued)

Burst Read/Write Operation

Synchronous burst read/write operation provides faster memory access that synchronized to microcontroller or system bus frequency. Configuration Register Set is required to perform burst read & write operation after power-up. Once CR Set sequence is performed to select synchronous burst mode, the device is configured to synchronous burst read/write operation mode with corresponding RL and BL that is set through CR Set sequence together with operation mode. In order to perform synchronous burst read & write operation, it is required to control new signals, CLK, ADV# and WAIT# that Low Power SRAMs don't have.

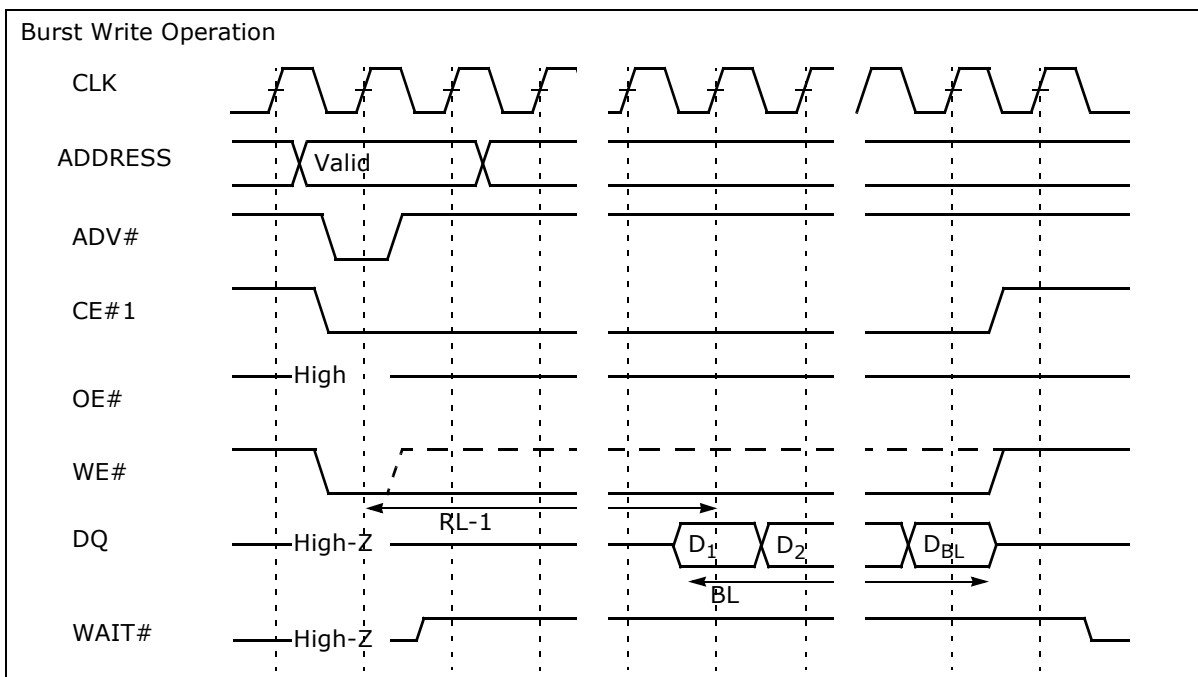
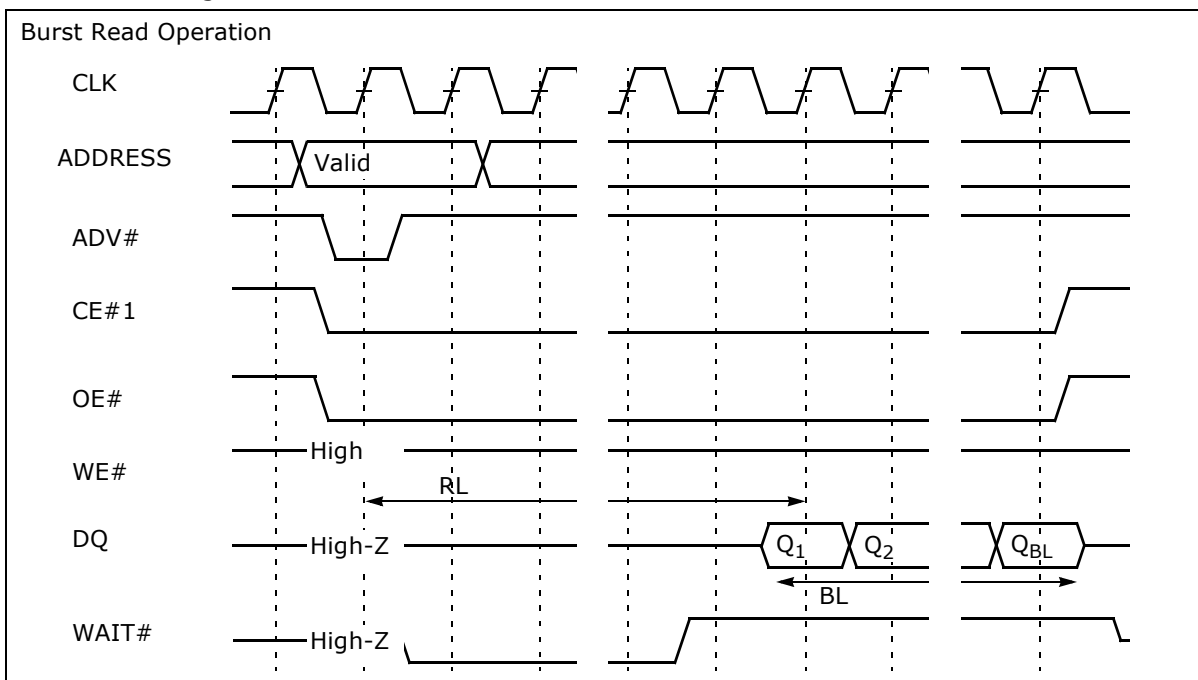

FUNCTIONAL DESCRIPTION (Continued)

CLK Input Function

The CLK is input signal to synchronize memory to microcontroller or system bus frequency during synchronous burst read & write operation. The CLK input increments device internal address counter and the valid edge of CLK is referred for latency counts from address latch, burst write data latch, and burst read data out. During synchronous operation mode, CLK input must be supplied except for standby state and power down state. CLK is don't care during asynchronous operation.

ADV# Input Function

The ADV# is input signal to indicate valid address presence on address inputs. It is applicable to synchronous operation as well as asynchronous operation. ADV# input is active during CE#1=L and CE#1=H disables ADV# input. All the address are determined on the positive edge of ADV#.

During synchronous burst read/write operation, ADV#=H disables all address inputs. Once ADV# is brought to High after valid address latch, it is inhibited to bring ADV# Low until the end of burst or until burst operation is terminated. ADV# Low pulse is mandatory for synchronous burst read/write operation mode to latch the valid address input.

During asynchronous operation, ADV#=H also disables all address inputs. ADV# can be tied to Low during asynchronous operation and it is not necessary to control ADV# to High.

WAIT# Output Function

The WAIT# is output signal to indicate data bus status when the device is operating in synchronous burst mode.

During burst read operation, WAIT# output is enabled after specified time duration from OE#=L. WAIT# output Low indicates data out at next clock cycle is invalid, and WAIT# output becomes High one clock cycle prior to valid data out. During OE# read suspend, WAIT# output doesn't indicate data bus status but carries the same level from previous clock cycle (kept High) except for read suspend on the final data output. If final read data out is suspended, WAIT# output become high impedance after specified time duration from OE#=H.

During burst write operation, WAIT# output is enabled to High level after specified time duration from WE#=L and kept High for entire write cycles including WE# write suspend. The actual write data latching starts on the appropriate clock edge with respect to Valid Click Edge, Read Latency and Burst Length. During WE# write suspend, WAIT# output doesn't indicate data bus status but carries the same level from previous clock cycle (kept High) except for write suspend on the final data input. If final write data in is suspended, WAIT# output become high impedance after specified time duration from WE#=H.

This device doesn't incur additional delay against accrossing device-row boundary or internal refresh orepation. Therefore, the burst operation is always started after fixed latency with respect to Read Latency. And there is no waiting cycle asserted in the middle of burst operation except for burst suspend by OE# brought to High or WE# brought to High. Thus, once WAIT# output is enabled and brought to High, WAIT# output keep High level until the end of burst or until the burst operation is terminated.

When the device is operating in asynchronous mode, WAIT# output is always in High Impedance.

FUNCTIONAL DESCRIPTION (Continued)

Latency

Read Latency (RL) is the number of clock cycles between the address being latched and first read data becoming available during synchronous burst read operation. It is set through CR Set sequence after power-up. Once specific RL is set through CR Set sequence, write latency, that is the number of clock cycles between address being latched and first write data being latched, is automatically set to RL-1. The burst operation is always started after fixed latency with respect to Read Latency set in CR.

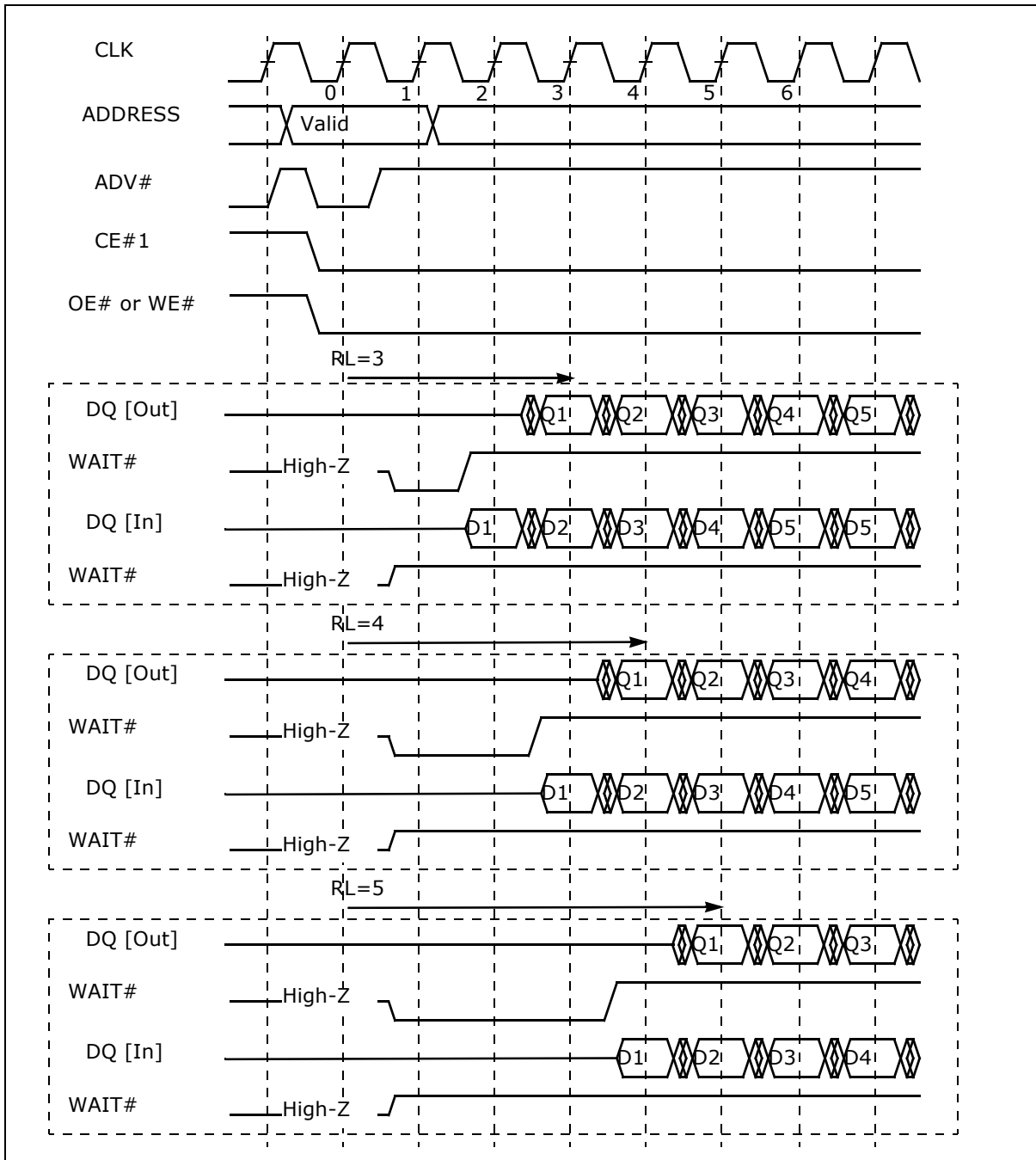

FUNCTIONAL DESCRIPTION (Continued)

Address Latch by ADV#

The ADV# indicates valid address presence on address inputs. During synchronous burst read/write operation mode, all the address are determined on the positive edge of ADV# when CE#1=L. The specified minimum value of ADV#=L setup time and hold time against valid edge of clock where RL count begin must be satisfied for appropriate RL counts. Valid address must be determined with specified setup time against either the negative edge of ADV# or negative edge of CE#1 whichever comes late. And the determined valid address must not be changed during ADV#=L period.

Burst Length

Burst Length is the number of word to be read or write during synchronous burst read/write operation as the result of a single address latch cycle. It can be set on 8, 16 words boundary or continuous for entire address through CR Set sequence. The burst type is sequential that is incremental decoding scheme within a boundary address. Starting from initial address being latched, device internal address counter assign +1 to the previous address until reaching the end of boundary address and then wrap round to least significant address (=0). After completing read data out or write data latch for the set burst length, operation automatically ended except for continuous burst length. When continuous burst length is set, read/write is endless unless it is terminated by the positive edge of CE#1.

Single Write

Single Write is synchronous write operation with Burst Length =1. The device can be configured either to "Burst Read & Single Write" or to "Burst Read & Burst Write" through CR set sequence. Once the device is configured to "Burst Read & Single Write" mode, the burst length for synchronous write operation is always fixed 1 regardless of BL values set in CR, while burst length for read is in accordance with BL values set in CR.

Write Control

The device has two type of WE# signal control method, "WE# Level Control" and "WE# Single Clock Pulse Control", for synchronous write operation. It is configured through CR set sequence.

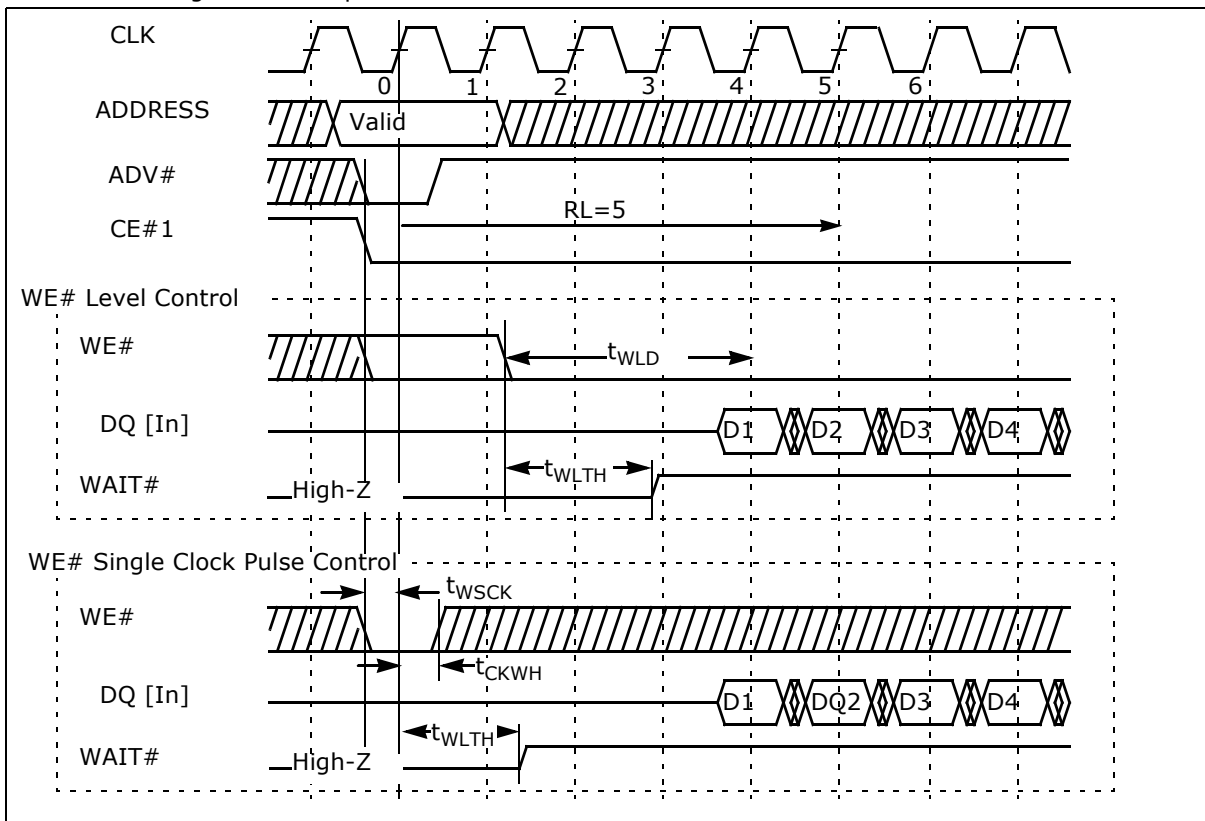

FUNCTIONAL DESCRIPTION (Continued)

Burst Read Suspend

Burst read operation can be suspended by OE# High pulse. During burst read operation, OE# brought to High suspends burst read operation. Once OE# is brought to High with the specified set up time against clock where the data being suspended, the device internal counter is suspended, and the data output become high impedance after specified time duration. It is inhibited to suspend the first data out at the beginning of burst read.

OE# brought to Low resumes burst read operation. Once OE# is brought to Low, data output become valid after specified time duration, and internal address counter is reactivated. The last data out being suspended as the result of OE#=H and first data out as the result of OE#=L are the from the same address.

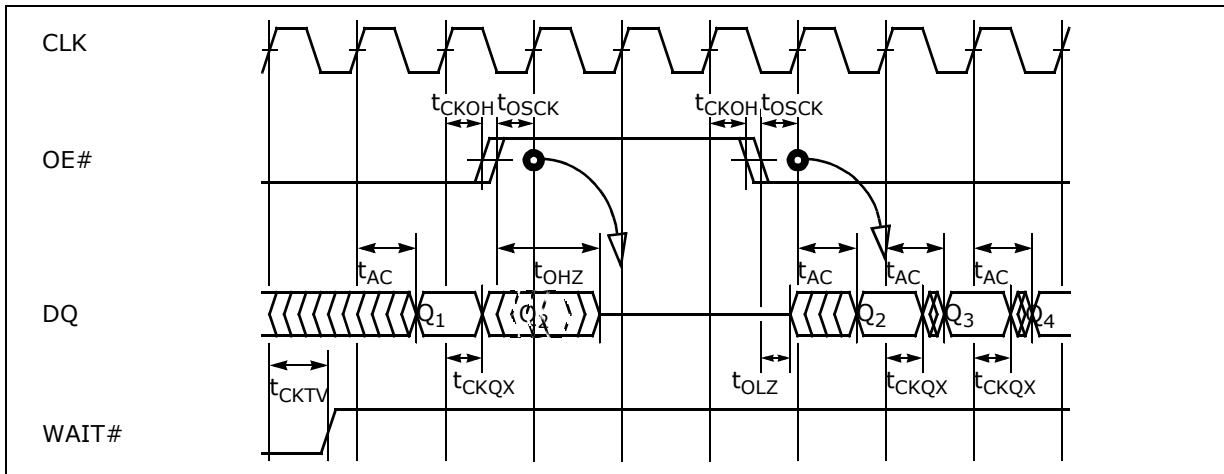

Burst Write Suspend

Burst write operation can be suspended by WE# High pulse. During burst write operation, WE# brought to High suspends burst write operation. Once WE# is brought to High with the specified set up time against clock where the data being suspended, device internal counter is suspended, data input is ignored. It is inhibited to suspend the first data input at the beginning of burst write.

WE# brought to Low resumes burst write operation. Once WE# is brought to Low, data input become valid after specified time duration, and internal address counter is reactivated. The write address of the cycle where data being suspended and the first write address as the result of WE#=L are the same address.

Burst write suspend function is available when the device is operating in WE# level controlled burst write only.

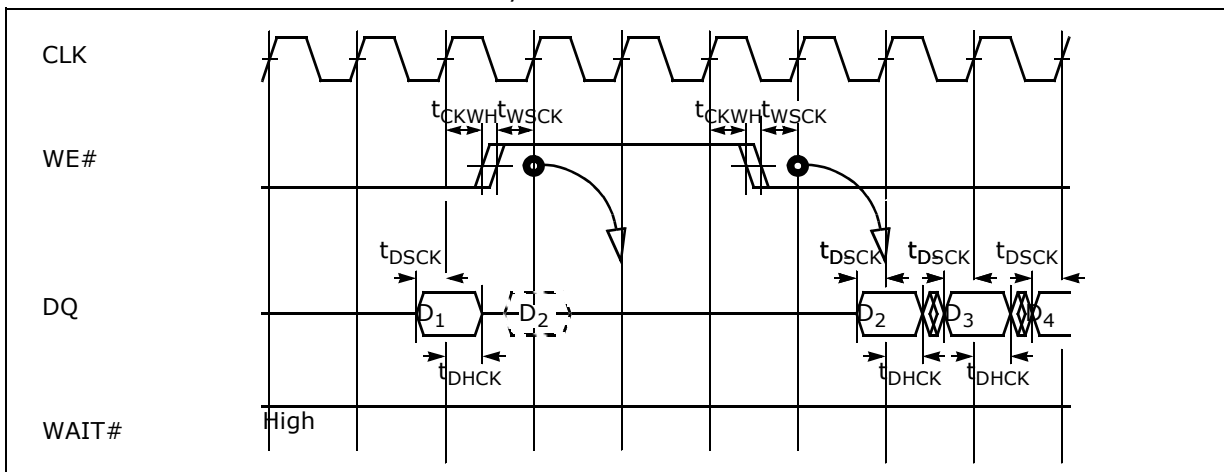

FUNCTIONAL DESCRIPTION (Continued)

Burst Read Termination

Burst read operation can be terminated by CE#1 brought to High. If BL is set on Continuous, burst read operation is continued endless unless terminated by CE#1=H. It is inhibited to terminate burst read before first data out is completed. In order to guarantee last data output, the specified minimum value of CE#1=L hold time from clock edge must be satisfied. After termination, the specified minimum recovery time is required to start new access.

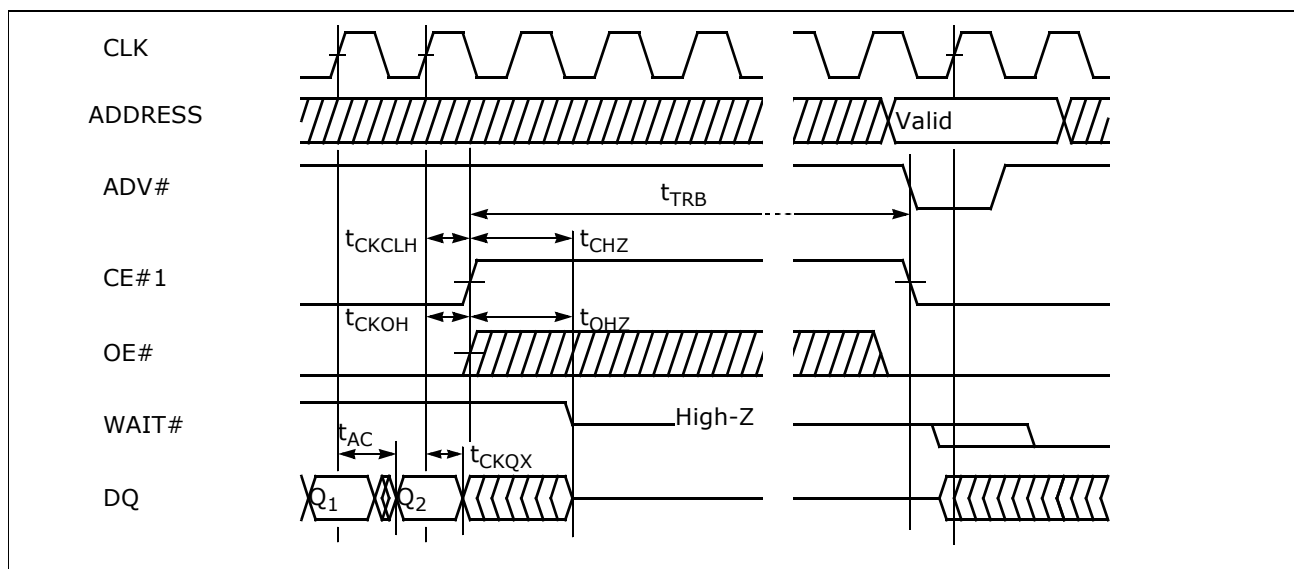

Burst Write Termination

Burst write operation can be terminated by CE#1 brought to High. If BL is set on Continuous, burst write operation is continued endless unless terminated by CE#1=H. It is inhibited to terminate burst write before first data in is completed. In order to guarantee last write data being latched, the specified minimum values of CE#1=L hold time from clock edge must be satisfied. After termination, the specified minimum recovery time is required to start new access.

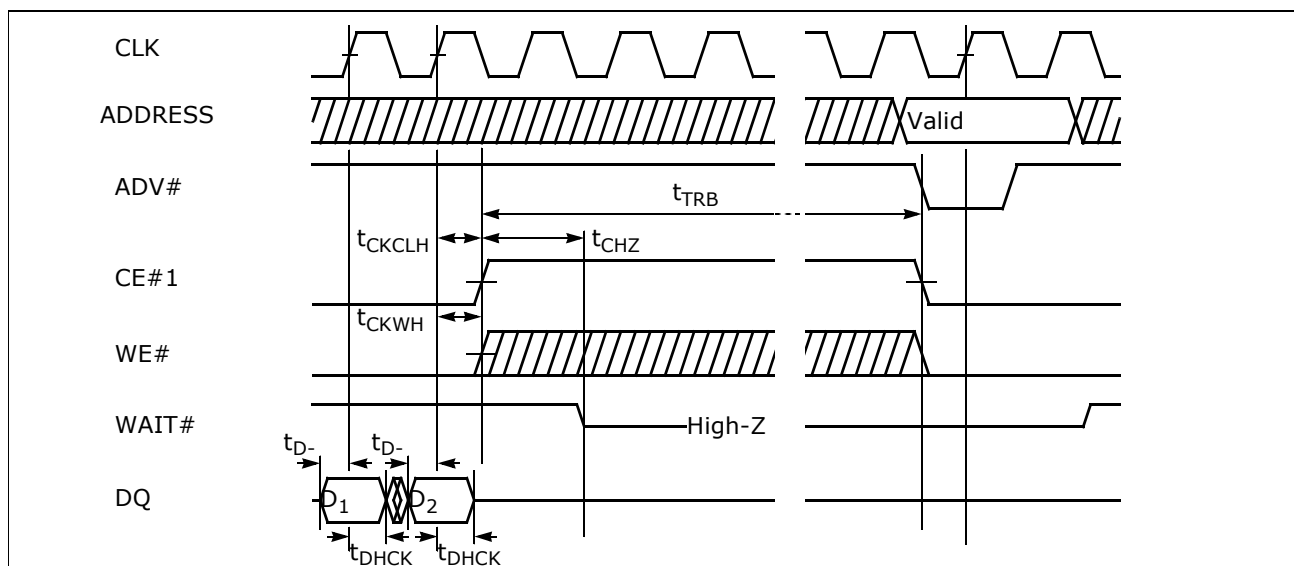

ABSOLUTE MAXIMUM RATINGS (See WARNING below.)

Parameter	Symbol	Value	Unit
Voltage of V_{DD} Supply Relative to V_{SS}	V_{DD}	-0.5 to +3.6	V
Voltage of V_{DDQ} Supply Relative to V_{SS}	V_{DDQ}	-0.5 to +2.6	V
Voltage at Any Pin Relative to V_{SS}	V_{IN}, V_{OUT}	-0.5 to +2.6	V
Short Circuit Output Current	I_{OUT}	± 50	mA
Storage Temperature	T_{STG}	-55 to +125	$^{\circ}C$

WARNING: Semiconductor devices can be permanently damaged by application of stress (voltage, current, temperature, etc.) in excess of absolute maximum ratings. Do not exceed these ratings.

RECOMMENDED OPERATING CONDITIONS (See WARNING below.)

(Referenced to V_{SS})

Parameter	Notes	Symbol	Min.	Max.	Unit
Supply Voltage		V_{DD}	2.6	3.1	V
DQ Supply Voltage		V_{DDQ}	1.65	1.95	V
Ground		V_{SS}	0	0	V
High Level Input Voltage	*1	V_{IH}	$V_{DDQ} * 0.8$	$V_{DDQ} + 0.2$	V
Low Level Input Voltage	*2	V_{IL}	-0.3	$V_{DDQ} * 0.2$	V
Ambient Temperature		T_A	-30	85	$^{\circ}C$

Notes *1: Maximum DC voltage on input and DQ pins are $V_{DDQ} + 0.2V$. During voltage transitions, inputs may positive overshoot to $V_{DDQ} + 1.0V$ for periods of up to 5 ns.

*2: Minimum DC voltage on input or DQ pins are $-0.3V$. During voltage transitions, inputs may negative overshoot V_{SS} to $-1.0V$ for periods of up to 5ns.

WARNING: Recommended operating conditions are normal operating ranges for the semiconductor device. All the device's electrical characteristics are warranted when operated within these ranges.

Always use semiconductor devices within the recommended operating conditions. Operation outside these ranges may adversely affect reliability and could result in device failure.

No warranty is made with respect to uses, operating conditions, or combinations not represented on the data sheet. Users considering application outside the listed conditions are advised to contact their FUJITSU representative beforehand.

DC CHARACTERISTICS

(Under Recommended Operating Conditions unless otherwise noted) Note *1,*2,*3

Parameter	Symbol	Test Conditions	Min.	Max.	Unit	
Input Leakage Current	I_{LI}	$V_{IN} = V_{SS}$ to V_{DDQ}	-1.0	+1.0	μA	
Output Leakage Current	I_{LO}	$V_{OUT} = V_{SS}$ to V_{DDQ} , Output Disable	-1.0	+1.0	μA	
Output High Voltage Level	V_{OH}	$V_{DDQ} = V_{DDQ}(\min)$, $I_{OH} = -0.5mA$	1.4	—	V	
Output Low Voltage Level	V_{OL}	$I_{OL} = 1mA$	—	0.4	V	
V_{DD} Power Down Current	I_{DDPS}	$V_{DD} = V_{DD} \max.$, $V_{DDQ} = V_{DDQ} \max.$, $V_{IN} = V_{IH}$ or V_{IL} , $CE2 \leq 0.2V$	SLEEP	—	10	μA
	I_{DDP16}		16M Partial	—	120	μA
	I_{DDP32}		32M Partial	—	150	μA
V_{DD} Standby Current	I_{DDS}	$V_{DD} = V_{DD} \max.$, $V_{DDQ} = V_{DDQ} \max.$, V_{IN} (including CLK) = V_{IH} or V_{IL} , $CE\#1 = CE2 = V_{IH}$	—	1.5	mA	
	I_{DDS1}	$V_{DD} = V_{DD} \max.$, $V_{DDQ} = V_{DDQ} \max.$, V_{IN} (including CLK) $\leq 0.2V$ or V_{IN} (including CLK) $\geq V_{DDQ} - 0.2V$, $CE\#1 = CE2 \geq V_{DDQ} - 0.2V$	—	300	μA	
	I_{DDS2}	$V_{DD} = V_{DD} \max.$, $V_{DDQ} = V_{DDQ} \max.$, $t_{CK} = \min.$, $V_{IN} \leq 0.2V$ or $V_{IN} \geq V_{DDQ} - 0.2V$, $CE\#1 = CE2 \geq V_{DDQ} - 0.2V$	—	350	μA	
V_{DD} Active Current	I_{DDA1}	$V_{DD} = V_{DD} \max.$, $V_{DDQ} = V_{DDQ} \max.$, $V_{IN} = V_{IH}$ or V_{IL} , $CE\#1 = V_{IL}$ and $CE2 = V_{IH}$, $I_{OUT} = 0mA$	$t_{RC} / t_{WC} =$ minimum	—	35	mA
	I_{DDA2}		$t_{RC} / t_{WC} =$ 1 μs	—	5	mA
V_{DD} Page Read Current	I_{DDA3}	$V_{DD} = V_{DD} \max.$, $V_{DDQ} = V_{DDQ} \max.$, $V_{IN} = V_{IH}$ or V_{IL} , $CE\#1 = V_{IL}$ and $CE2 = V_{IH}$, $I_{OUT} = 0mA$, $t_{PRC} = \min.$	—	15	mA	
V_{DD} Burst Access Current	I_{DDA4}	$V_{DD} = V_{DD} \max.$, $V_{DDQ} = V_{DDQ} \max.$, $V_{IN} = V_{IH}$ or V_{IL} , $CE\#1 = V_{IL}$ and $CE2 = V_{IH}$, $t_{CK} = t_{CK} \min.$, BL = Continuous, $I_{OUT} = 0mA$,	—	30	mA	

Notes *1: All voltages are referenced to V_{SS} .

*2: DC Characteristics are measured after following POWER-UP timing.

*3: I_{OUT} depends on the output load conditions.

AC CHARACTERISTICS

(Under Recommended Operating Conditions unless otherwise noted)

ASYNCHRONOUS READ OPERATION (PAGE MODE)

Parameter	Symbol	Value		Unit	Notes
		Min.	Max.		
Read Cycle Time	t_{RC}	70	1000	ns	*1, *2
CE#1 Access Time	t_{CE}	—	70	ns	*3
OE# Access Time	t_{OE}	—	40	ns	*3
Address Access Time	t_{AA}	—	70	ns	*3, *5
ADV# Access Time	t_{AV}	—	70	ns	*3
LB#, UB# Access Time	t_{BA}	—	30	ns	*3
Page Address Access Time	t_{PAA}	—	20	ns	*3, *6
Page Read Cycle Time	t_{PRC}	20	1000	ns	*1, *6, *7
Output Data Hold Time	t_{OH}	5	—	ns	*3
CE#1 Low to Output Low-Z	t_{CLZ}	5	—	ns	*4
OE# Low to Output Low-Z	t_{OLZ}	0	—	ns	*4
LB#, UB# Low to Output Low-Z	t_{BLZ}	0	—	ns	*4
CE#1 High to Output High-Z	t_{CHZ}	—	20	ns	*3
OE# High to Output High-Z	t_{OHZ}	—	20	ns	*3
LB#, UB# High to Output High-Z	t_{BHZ}	—	20	ns	*3
Address Setup Time to CE#1 Low	t_{ASC}	-5	—	ns	
Address Setup Time to OE# Low	t_{ASO}	10	—	ns	
ADV# Low Pulse Width	t_{VPL}	10	—	ns	*8
Address Hold Time from ADV# High	t_{AHV}	5	—	ns	
Address Invalid Time	t_{AX}	—	10	ns	*5, *9
Address Hold Time from CE#1 High	t_{CHAH}	-5	—	ns	*10
Address Hold Time from OE# High	t_{OHAH}	-5	—	ns	
CE#1 High Pulse Width	t_{CP}	15	—	ns	

Notes *1: Maximum value is applicable if CE#1 is kept at Low without change of address input of A3 to A22. If needed by system operation, please contact local FUJITSU representative for the relaxation of 1ms limitation.

*2: Address Should Not Be Changed Within Minimum T_{RC} .

*3: The output load 50pF with 50ohm termination to $V_{DDQ} * 0.5 V$.

*4: The output load 5pF without any other load.

*5: Applicable to A3 to A22 when CE#1 is kept at Low.

*6: Applicable only to A0, A1 and A2 when CE#1 is kept at Low for the page address access.

*7: In case Page Read Cycle is continued with keeping CE#1 stays Low, CE#1 must be brought to High within 4ms. In other words, Page Read Cycle must be closed within 4ms.

*8: t_{VPL} is specified from the negative edge of either CE#1 or ADV# whichever comes late.

*9: Applicable when at least two of address inputs among applicable are switched from previous state.

*10: $t_{RC}(\min)$ and $t_{PRC}(\min)$ must be satisfied.

AC CHARACTERISTICS (Continued)

ASYNCHRONOUS WRITE OPERATION

Parameter	Symbol	Value		Unit	Notes
		Min.	Max.		
Write Cycle Time	t_{WC}	70	1000	ns	*1, *2
Address Setup Time	t_{AS}	0	—	ns	*3
ADV# Low Pulse Width	t_{VPL}	10	—	ns	*4
Address Hold Time from ADV# High	t_{AHV}	5	—	ns	
CE#1 Write Pulse Width	t_{CW}	45	—	ns	*3
WE# Write Pulse Width	t_{WP}	45	—	ns	*3
LB#, UB# Write Pulse Width	t_{BW}	45	—	ns	*3
CE#1 Write Recovery Time	t_{WRC}	15	—	ns	*5
WE# Write Recovery Time	t_{WR}	15	1000	ns	*5
LB#, UB# Write Recovery Time	t_{BR}	15	1000	ns	*5
Data Setup Time	t_{DS}	15	—	ns	
Data Hold Time	t_{DH}	0	—	ns	
OE# High to CE#1 Low Setup Time for Write	t_{OHCL}	-5	—	ns	*6
OE# High to Address Setup Time for Write	t_{OES}	0	—	ns	*7
LB#, UB# Write Pulse Overlap	t_{BWO}	30	—	ns	
CE#1 High Pulse Width	t_{CP}	15	—	ns	

- Notes**
- *1: Maximum value is applicable if CE#1 is kept at Low without any address change. If the relaxation is needed by system operation, please contact local FUJITSU representative for the relaxation of 1ms limitation.
 - *2: Minimum value must be equal or greater than the sum of write pulse (t_{CW} , t_{WP} or t_{BW}) and write recovery time (t_{WRC} , t_{WR} or t_{BR}).
 - *3: Write pulse is defined from High to Low transition of CE#1, WE# or LB# / UB#, whichever occurs last.
 - *4: t_{VPL} is specified from the negative edge of either CE#1 or ADV# whichever comes late.
 - *5: Write recovery is defined from Low to High transition of CE#1, WE# or LB# / UB#, whichever occurs first.
 - *6: If OE# is Low after minimum t_{OHCL} , read cycle is initiated. In other word, OE# must be brought to High within 5ns after CE#1 is brought to Low. Once read cycle is initiated, new write pulse should be input after minimum t_{RC} is met.
 - *7: If OE# is Low after new address input, read cycle is initiated. In other word, OE# must be brought to High at the same time or before new address valid. Once read cycle is initiated, new write pulse should be input after minimum t_{RC} is met and data bus is in High-Z.

AC CHARACTERISTICS (Continued)

SYNCHRONOUS OPERATION - CLOCK INPUT (BURST MODE)

Parameter		Symbol	Value		Unit	Notes
			Min.	Max.		
Clock Period	RL=5	t_{CK}	13	—	ns	*1
	RL=4		18	—	ns	*1
	RL=3		30	—	ns	*1
Clock High Time		t_{CKH}	4	—	ns	
Clock Low Time		t_{CKL}	4	—	ns	
Clock Rise/Fall Time		t_{CKT}	—	3	ns	*2

Notes *1: Clock period is defined between valid clock edge.
 *2: Clock rise/fall time is defined between V_{IH} Min. and V_{IL} Max.

SYNCHRONOUS OPERATION - ADDRESS LATCH (BURST MODE)

Parameter		Symbol	Value		Unit	Notes
			Min.	Max.		
Address Setup Time to ADV# Low		t_{ASVL}	-5	—	ns	*1
Address Setup Time to CE#1 Low		t_{ASCL}	-5	—	ns	*1
Address Hold Time from ADV# High		t_{AHV}	5	—	ns	
ADV# Low Pulse Width		t_{VPL}	10	—	ns	*2
ADV# Low Setup Time to CLK		t_{VSCK}	5	—	ns	*3
ADV# Low Setup Time to CE#1 Low		t_{VLCL}	5	—	ns	*1
CE#1 Low Setup Time to CLK		t_{CLCK}	5	—	ns	*3
ADV# Low Hold Time from CLK		t_{CKVH}	1	—	ns	*3
Burst End ADV High Hold Time from CLK		t_{VHVL}	13	—	ns	

Notes *1: t_{ASCL} is applicable if CE#1 brought to Low after ADV# is brought to Low under the condition where t_{VLCL} is satisfied. The both of t_{ASCL} and t_{ASVL} must be satisfied if t_{VLCL} is not satisfied.
 *2: t_{VPL} is specified from the negative edge of either CE#1 or ADV# whichever comes late.
 *3: Applicable to the 1st valid clock edge.

AC CHARACTERISTICS (Continued)

SYNCHRONOUS READ OPERATION (BURST MODE)

Parameter	Symbol	Value		Unit	Notes	
		Min.	Max.			
Burst Read Cycle Time	t_{RCB}	—	8000	ns		
CLK Access Time	t_{AC}	—	11	ns	*1	
Output Hold Time from CLK	t_{CKQX}	3	—	ns	*1	
CE#1 Low to WAIT# Low	t_{CLTL}	5	20	ns	*1	
OE# Low to WAIT# Low	t_{OLTL}	0	20	ns	*1	
ADV# Low to WAIT# Low	t_{VLTL}	0	20	ns	*1	
CLK to WAIT# Valid Time	t_{CKTV}	—	11	ns	*1	
WAIT# Valid Hold Time from CLK	t_{CKTX}	3	—	ns	*1	
CE#1 Low to Output Low-Z	t_{CLZ}	5	—	ns	*2	
OE# Low to Output Low-Z	t_{OLZ}	0	—	ns	*2	
LB#, UB# Low to Output Low-Z	t_{BLZ}	0	—	ns	*2	
CE#1 High to Output High-Z	t_{CHZ}	—	20	ns	*1	
OE# High to Output High-Z	t_{OHZ}	—	20	ns	*1	
LB#, UB# High to Output High-Z	t_{BHZ}	—	20	ns	*1	
CE#1 High to WAIT# High-Z	t_{CHTZ}	—	20	ns	*1	
OE# High to WAIT# High-Z	t_{OHTZ}	—	20	ns	*1	
OE# Low Setup Time to 1st Data-out	t_{OLQ}	30	—	ns		
UB#, LB# Setup Time to 1st Data-out	t_{BSQ}	26	—	ns	*3	
OE# Setup Time to CLK	t_{OSCK}	5	—	ns		
OE# Hold Time from CLK	t_{CKOH}	5	—	ns		
Burst End CE#1 Low Hold Time from CLK	t_{CKCLH}	5	—	ns		
Burst End UB#, LB# Hold Time from CLK	t_{CKBH}	5	—	ns		
Burst Terminate Recovery Time	BL=8,16	t_{TRB}	26	—	ns	*4
	BL=Continuous		70	—	ns	*4

Notes *1: The output load 50pF with 50ohm termination to $V_{DDQ} * 0.5 V$.

*2: The output load 5pF without any other load.

*3: Once they are determined, they must not be changed until the end of burst.

*4: Defined from the Low to High transition of CE#1 to the High to Low transition of either ADV# or CE#1 whichever occurs late.

AC CHARACTERISTICS (Continued)

SYNCHRONOUS WRITE OPERATION (BURST MODE)

Parameter	Symbol	Value		Unit	Notes	
		Min.	Max.			
Burst Write Cycle Time	t_{WCB}	—	8000	ns		
Data Setup Time to Clock	t_{DSCK}	5	—	ns		
Data Hold Time from CLK	t_{DHCK}	3	—	ns		
WE# Low Setup Time to 1st Data In	t_{WLD}	30	—	ns		
UB#, LB# Setup Time for Write	t_{BS}	-5	—	ns	*1	
WE# Setup Time to CLK	t_{WSCK}	5	—	ns		
WE# Hold Time from CLK	t_{CKWH}	5	—	ns		
CE#1 Low to WAIT# High	t_{CLTH}	5	20	ns	*2	
WE# Low to WAIT# High	t_{WLTH}	0	20	ns	*2	
CE#1 High to WAIT# High-Z	t_{CHTZ}	—	20	ns	*2	
WE# High to WAIT# High-Z	t_{WHTZ}	—	20	ns	*2	
Burst End CE#1 Low Hold Time from CLK	t_{CKCLH}	5	—	ns		
Burst End CE#1 High Setup Time to next CLK	t_{CHCK}	5	—	ns		
Burst End UB#, LB# Hold Time from CLK	t_{CKBH}	5	—	ns		
Burst Write Recovery Time	t_{WRB}	26		ns	*3	
Burst Terminate Recovery Time	BL=8,16	t_{TRB}	26	—	ns	*4
	BL=Continuous	t_{TRB}	70	—	ns	*4

- Notes**
- *1: Defined from the valid input edge to the High to Low transition of either ADV#, CE#1, or WE#, whichever occurs last. And once they are determined, they must not be changed until the end of burst.
 - *2: The output load 50pF with 50ohm termination to $V_{DDQ} * 0.5 V$.
 - *3: Defined from the valid clock edge where last data-in being latched at the end of burst write to the High to Low transition of either ADV# or CE#1 whichever occurs late for the next access.
 - *4: Defined from the Low to High transition of CE#1 to the High to Low transition of either ADV# or CE#1 whichever occurs late for the next access.

AC CHARACTERISTICS (Continued)

POWER DOWN PARAMETERS

Parameter	Symbol	Value		Unit	Note
		Min.	Max.		
CE2 Low Setup Time for Power Down Entry	t_{CSP}	20	—	ns	*1
CE2 Low Hold Time after Power Down Entry	t_{C2LP}	70	—	ns	*1
CE#1 High Hold Time following CE2 High after Power Down Exit [SLEEP mode only]	t_{CHH}	300	—	μ s	*1
CE#1 High Hold Time following CE2 High after Power Down Exit [not in SLEEP mode]	t_{CHHP}	1	—	μ s	*2
CE#1 High Setup Time following CE2 High after Power Down Exit	t_{CHS}	0	—	μ s	*1

Notes *1: Applicable also to power-up.

*2: Applicable when Partial mode is set.

OTHER TIMING PARAMETERS

Parameter	Symbol	Value		Unit	Note
		Min.	Max.		
CE#1 High to OE# Invalid Time for Standby Entry	t_{CHOX}	10	—	ns	
CE#1 High to WE# Invalid Time for Standby Entry	t_{CHWX}	10	—	ns	*1
CE2 High Hold Time after Power-up	t_{C2HL}	50	—	μ s	
CE#1 High Hold Time following CE2 High after Power-up	t_{CHH}	300	—	μ s	
Input Transition Time (except for CLK)	t_T	1	25	μ s	*2, *3

Notes *1: Some data might be written into any address location if $t_{CHWX}(min)$ is not satisfied.

*2: Except for clock input transition time.

*3: The Input Transition Time (t_T) at AC testing is shown in below. If actual t_T is longer than specified values, it may violate AC specification of some timing parameters.

AC CHARACTERISTICS (Continued)

AC TEST CONDITIONS

Symbol	Description	Test Setup	Value	Unit	Note
V_{IH}	Input High Level		$V_{IOPS} * 0.8$	V	
V_{IL}	Input Low Level		$V_{IOPS} * 0.2$	V	
V_{REF}	Input Timing Measurement Level		$V_{IOPS} * 0.5$	V	
t_T	Input Transition Time	Async.	Between V_{IL} and V_{IH}	5	ns
		Sync.		3	ns

AC MEASUREMENT OUTPUT LOAD CIRCUIT

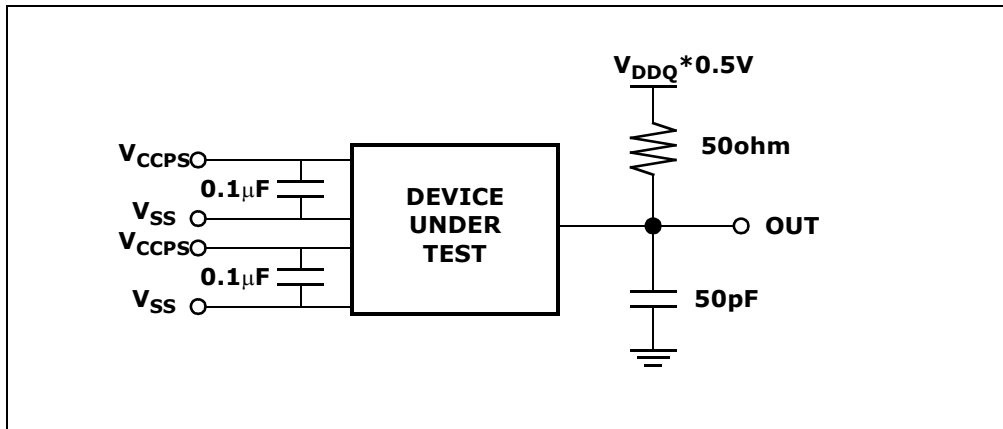

TIMING DIAGRAMS

Asynchronous Read Timing #1-1 (Basic Timing).

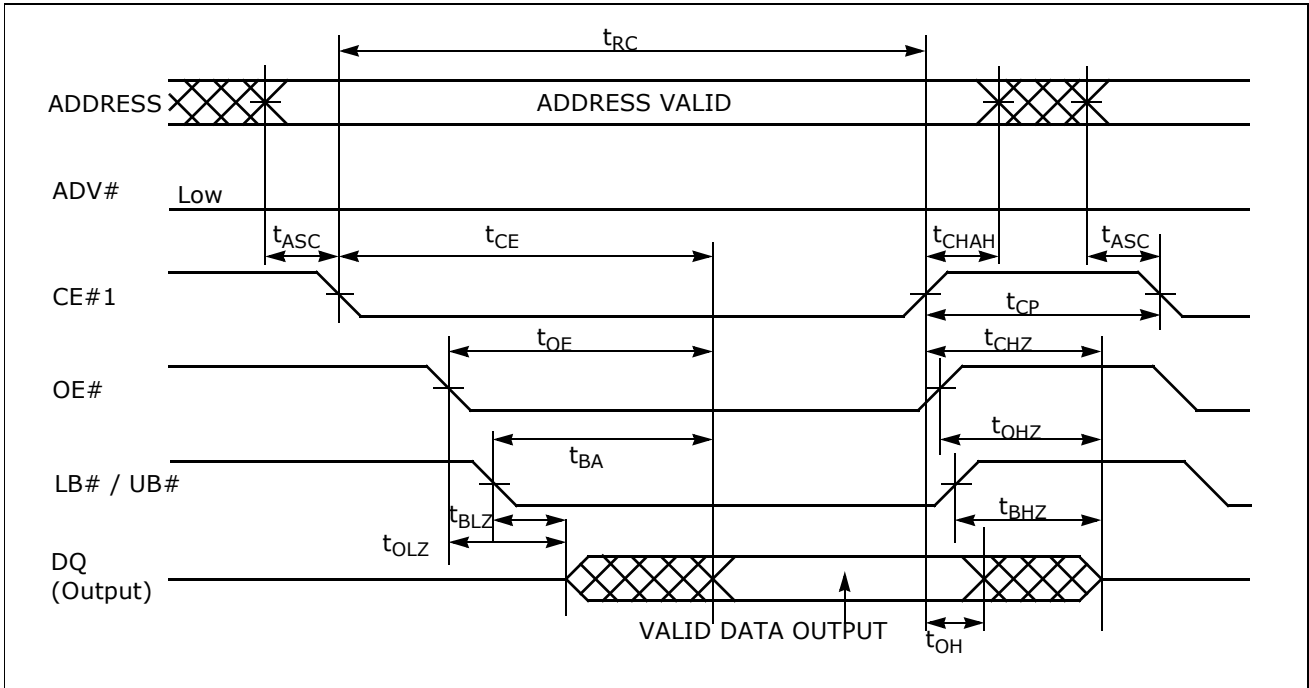

Note: This timing diagram assumes CE2=H and WE#=H.

Asynchronous Read Timing #1-2 (Basic Timing)

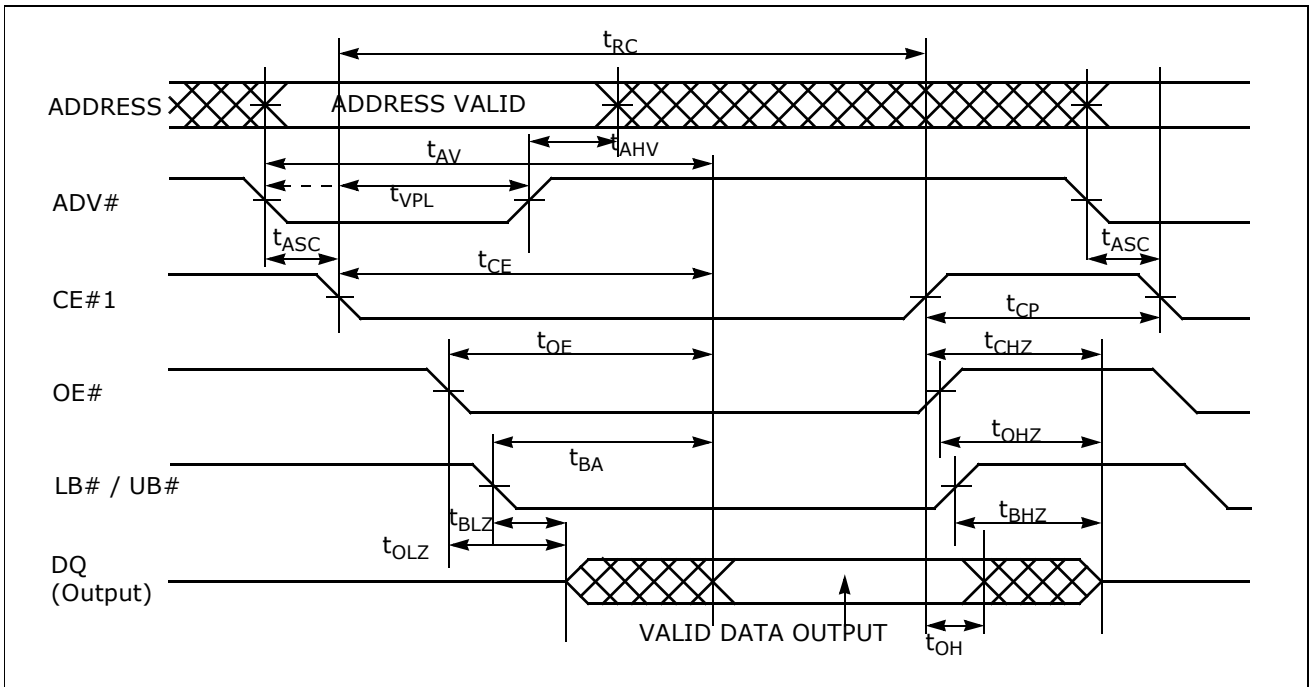

Note: This timing diagram assumes CE2=H and WE#=H.

TIMING DIAGRAMS (Continued)

Asynchronous Read Timing #2 (OE# & Address Access)

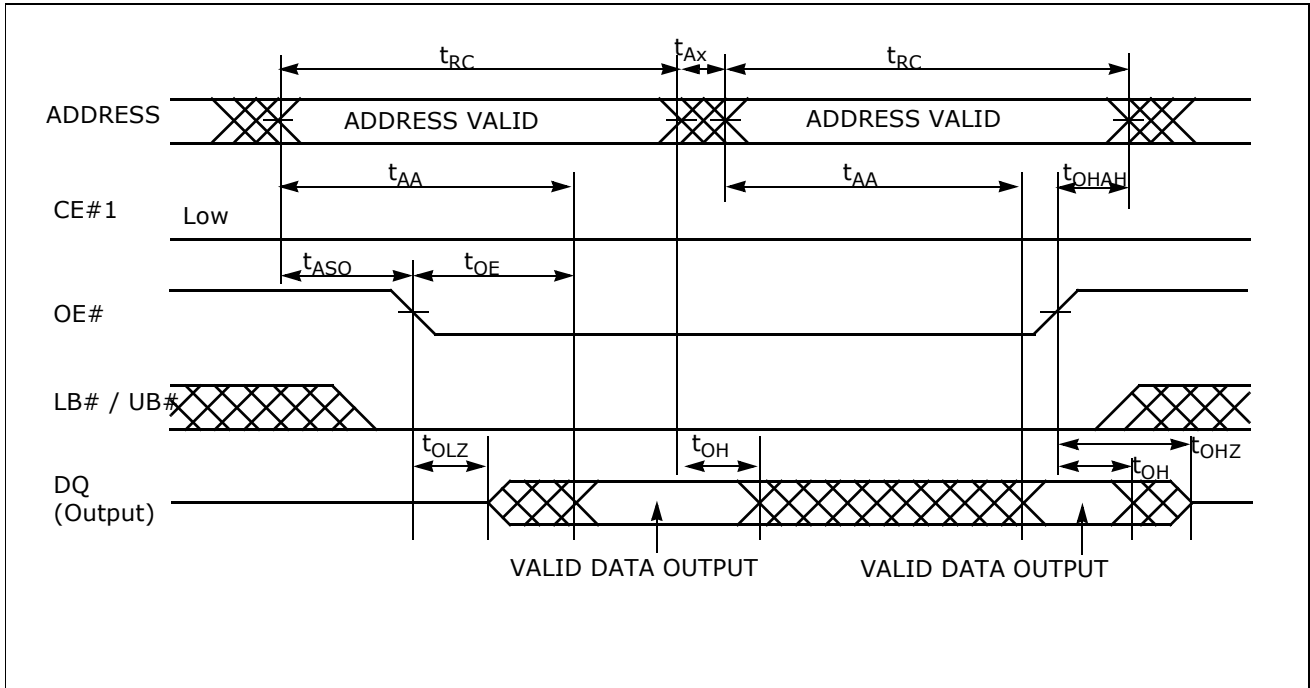

Notes: This timing diagram assumes $CE2=H$, $ADV#=L$ and $WE#=H$.

Asynchronous Read Timing #3 (LB# / UB# Byte Access)

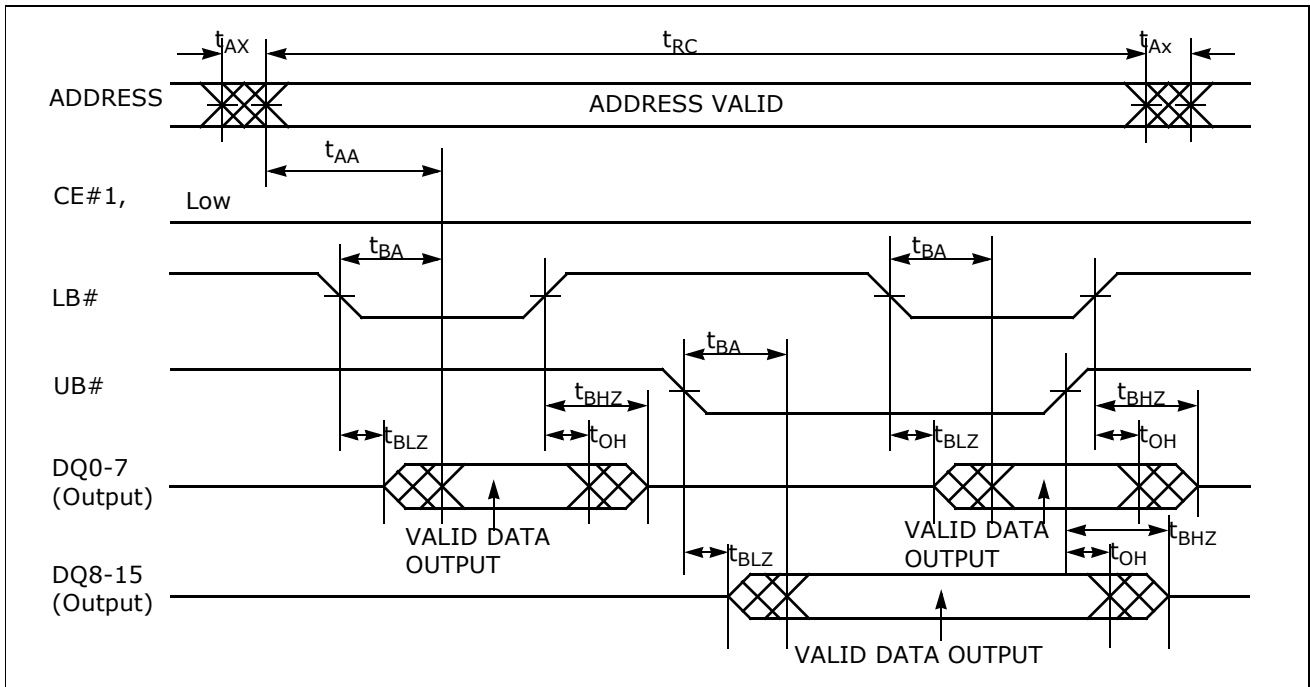

Note: This timing diagram assumes $CE2=H$, $ADV#=L$ and $WE#=H$.

TIMING DIAGRAMS (Continued)

Asynchronous Read Timing #4 (Page Address Access after CE#1 Control Access)

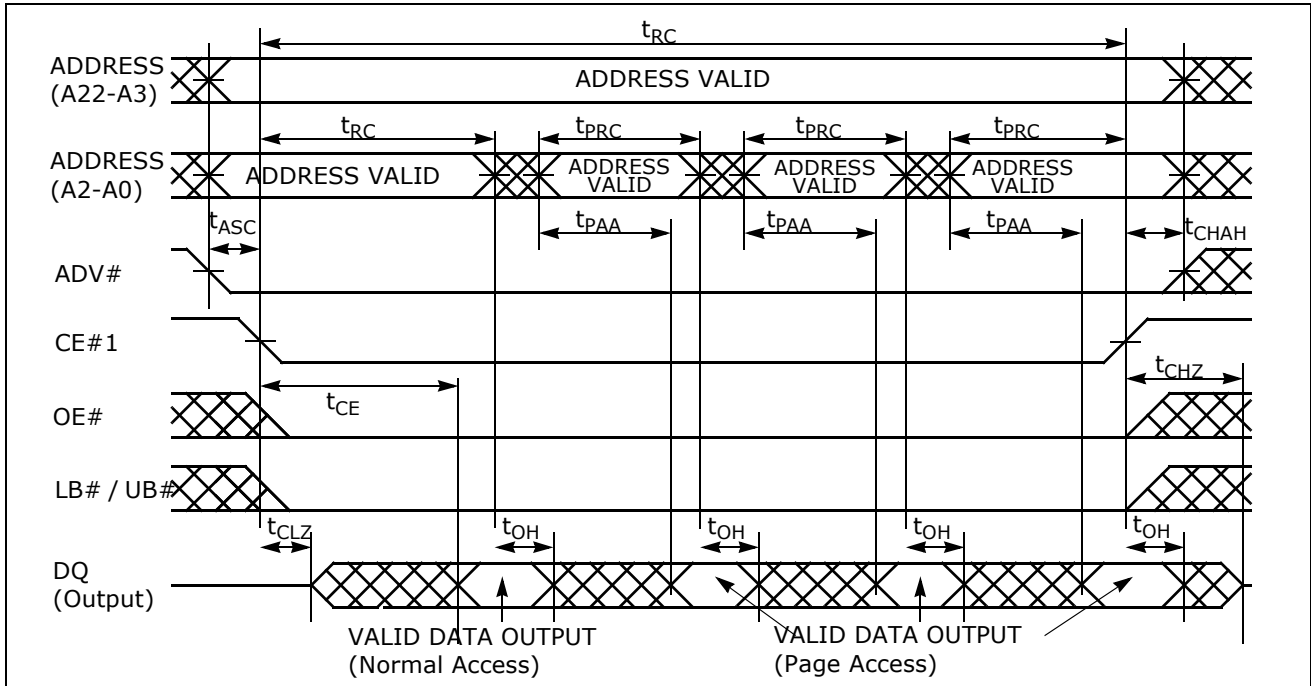

Notes: This timing diagram assumes $CE2=H$ and $WE#=H$.

Asynchronous Read Timing #5 (Random and Page Address Access)

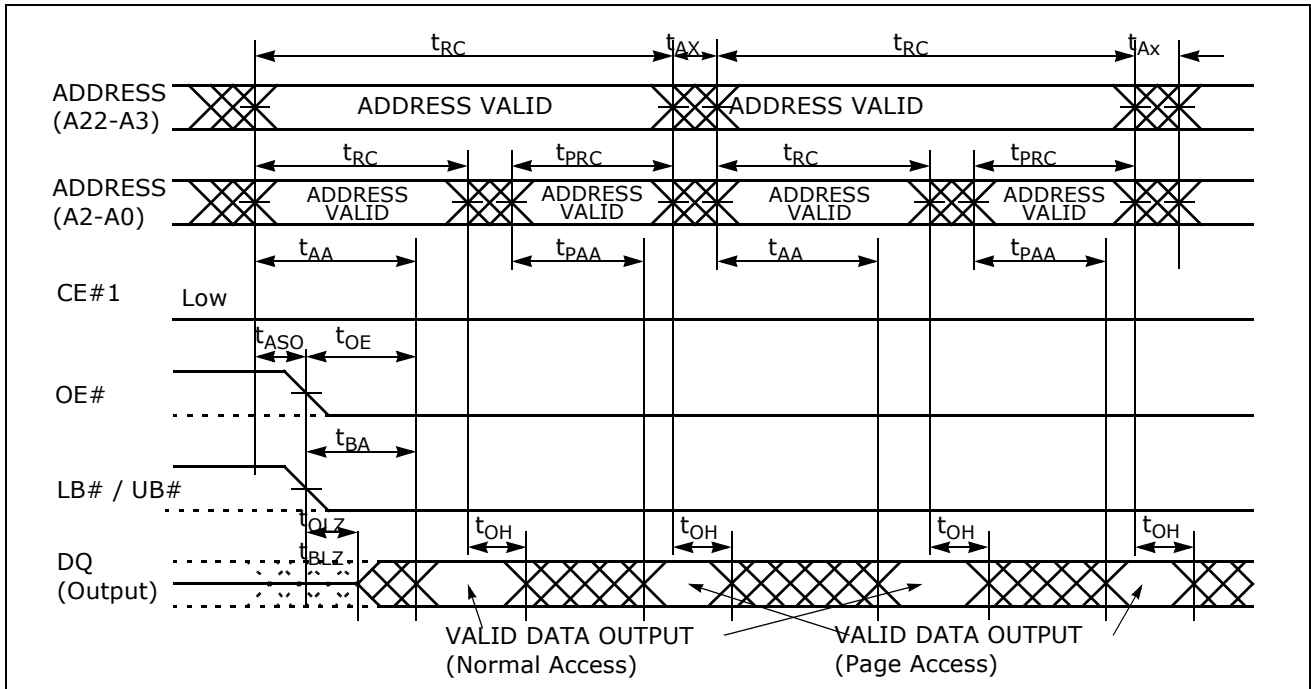

Notes *1: This timing diagram assumes $CE2=H$, $ADV#=L$ and $WE#=H$.

*2: Either or both $LB\#$ and $UB\#$ must be Low when both $CE\#1$ and $OE\#$ are Low.

TIMING DIAGRAMS (Continued)

Asynchronous Write Timing #1-1 (Basic Timing)

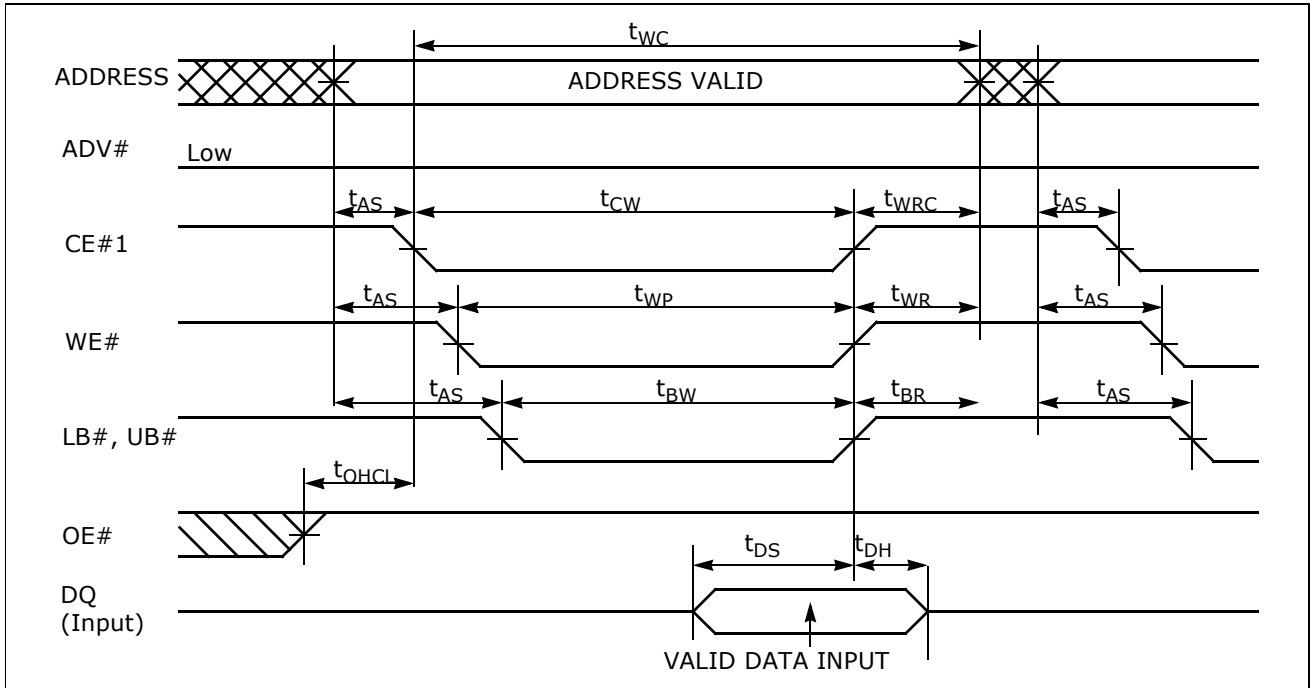

Notes: This timing diagram assumes CE2=H and ADV#=L.

Asynchronous Write Timing #1-2 (Basic Timing)

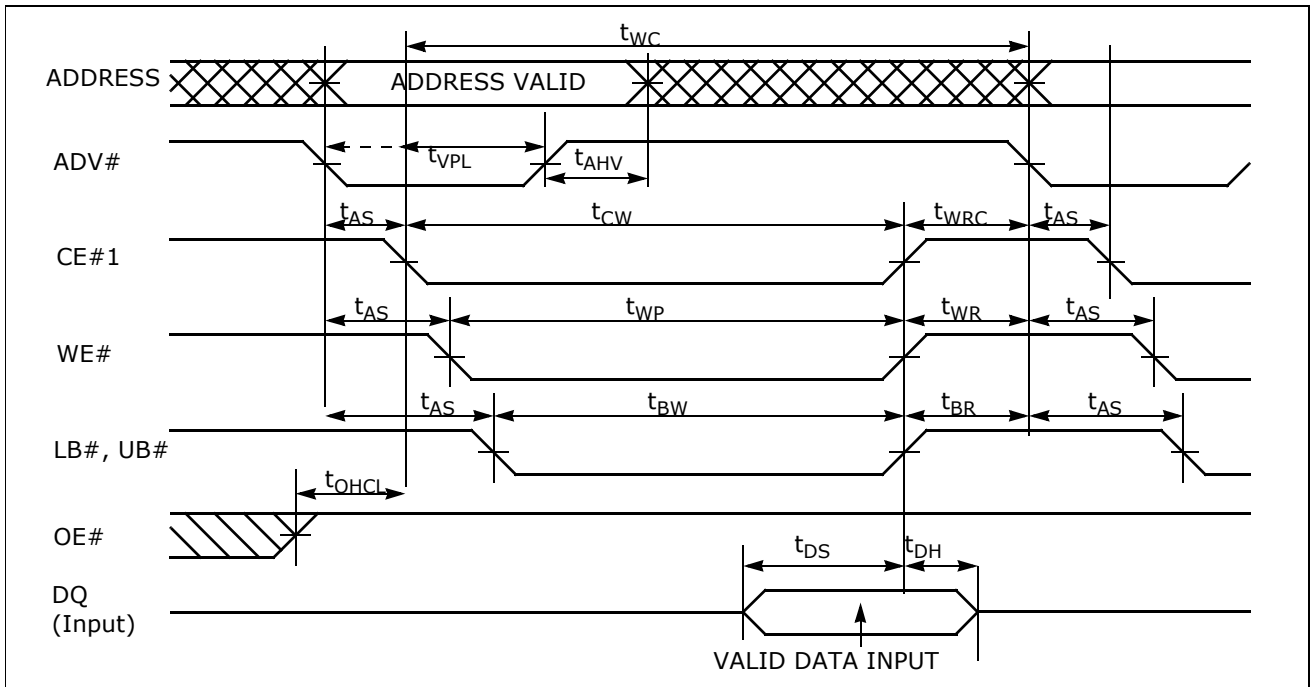

Notes: This timing diagram assumes CE2=H.

TIMING DIAGRAMS (Continued)

Asynchronous Write Timing #2 (WE# Control)

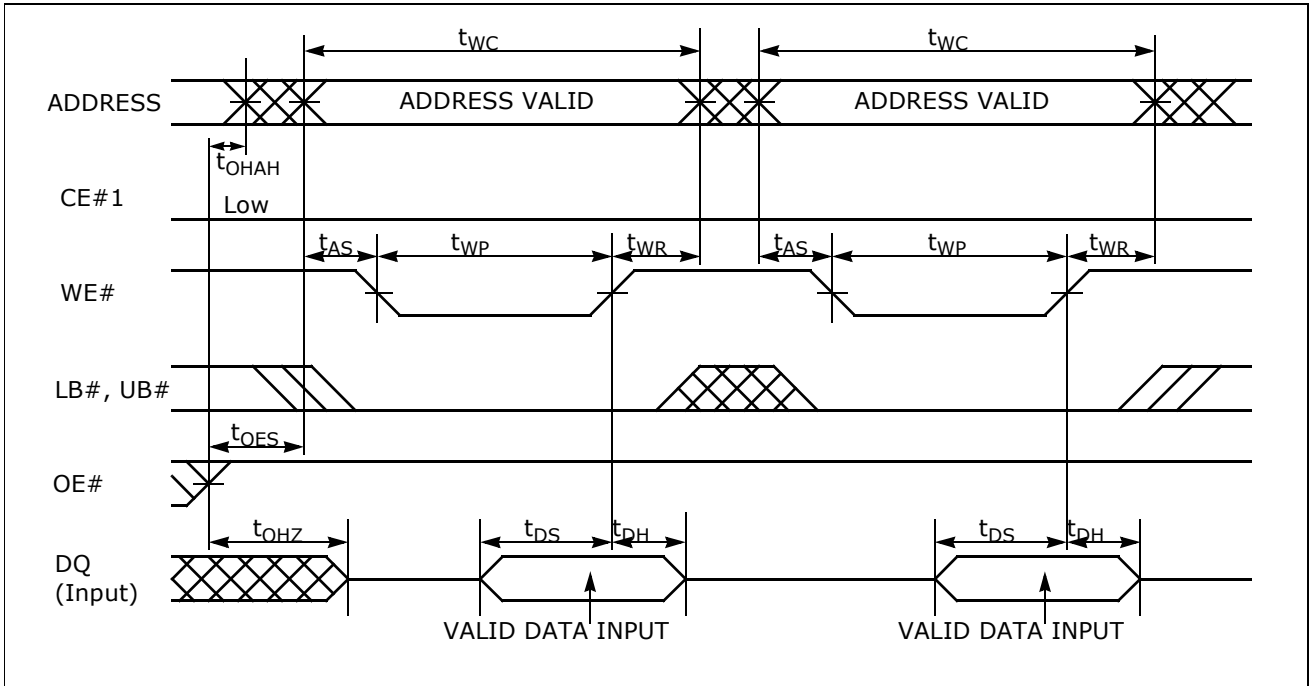

Note: This timing diagram assumes $CE2=H$ and $ADV#=L$.

Asynchronous Write Timing #3-I (WE# / LB# / UB# Byte Write Control)

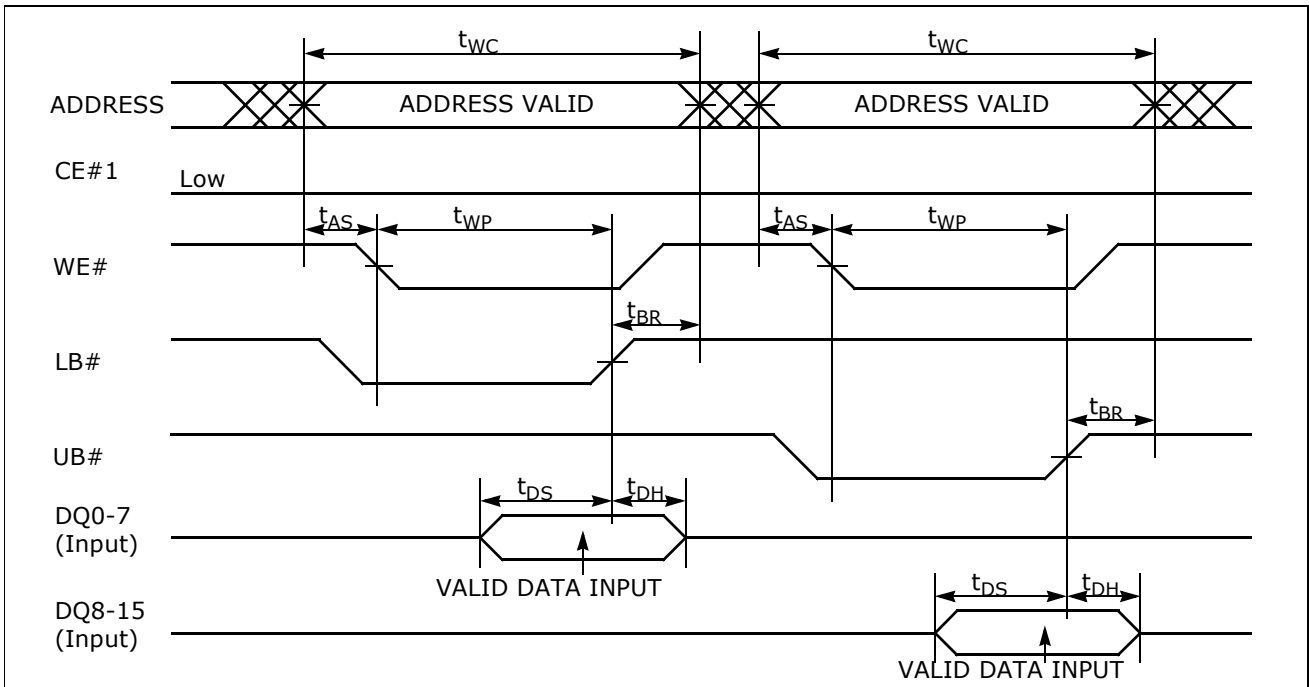

Note: This timing diagram assumes $CE2=H$, $ADV#=L$ and $OE#=H$.

TIMING DIAGRAMS (Continued)

Asynchronous Write Timing #3-2 (WE# / LB# / UB# Byte Write Control)

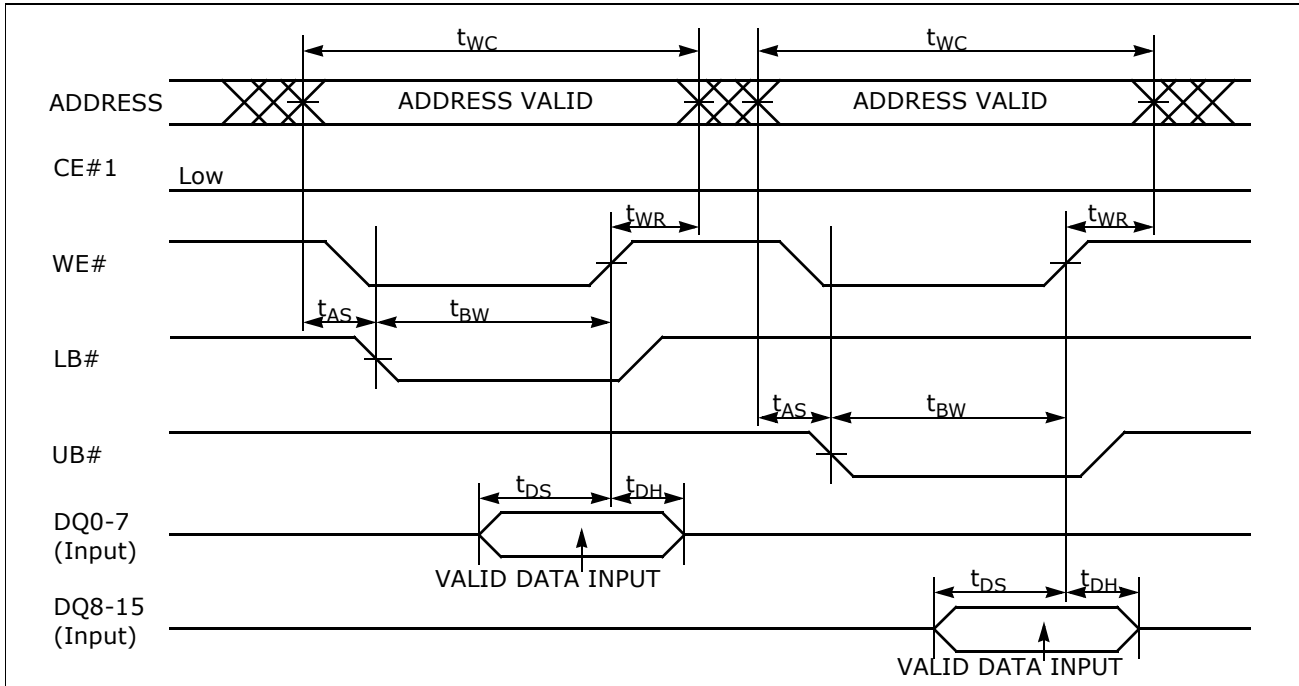

Note: This timing diagram assumes CE2=H, ADV#=L and OE#=H.

Asynchronous Write Timing #3-3 (WE# / LB# / UB# Byte Write Control)

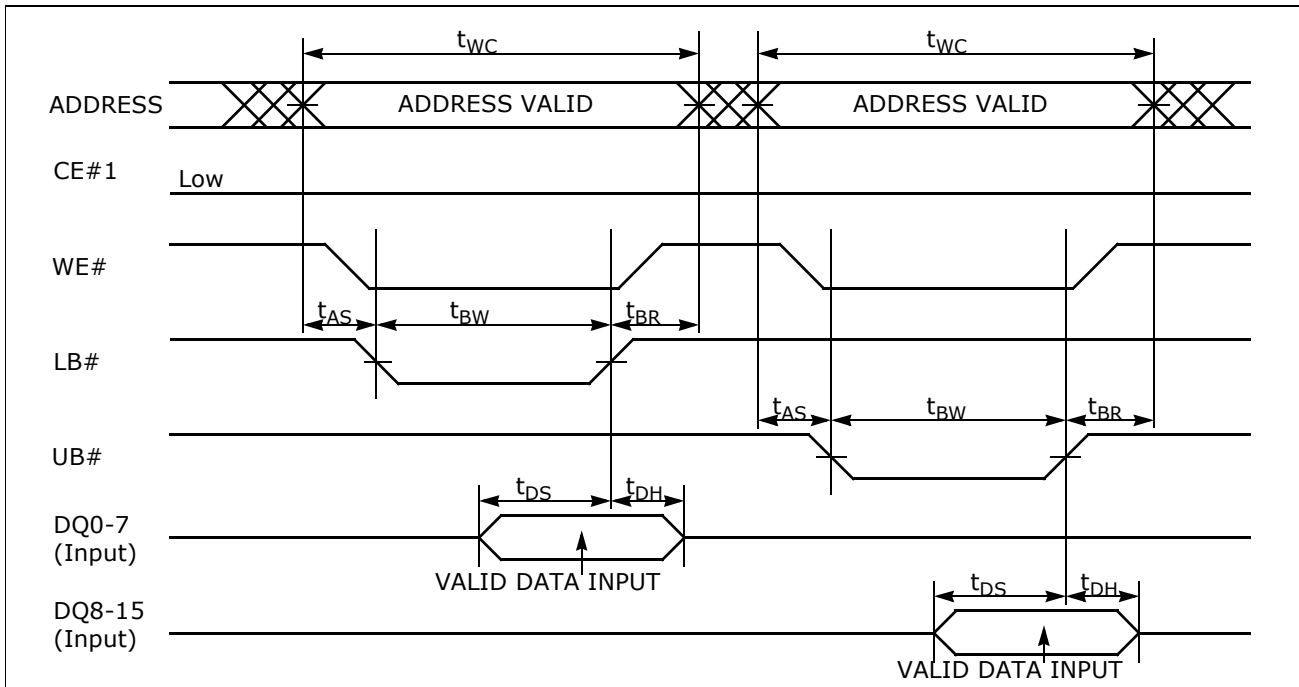

Note: This timing diagram assumes CE2=H, ADV#=L and OE#=H.

TIMING DIAGRAMS (Continued)

Asynchronous Write Timing #3-4 (WE# / LB# / UB# Byte Write Control)

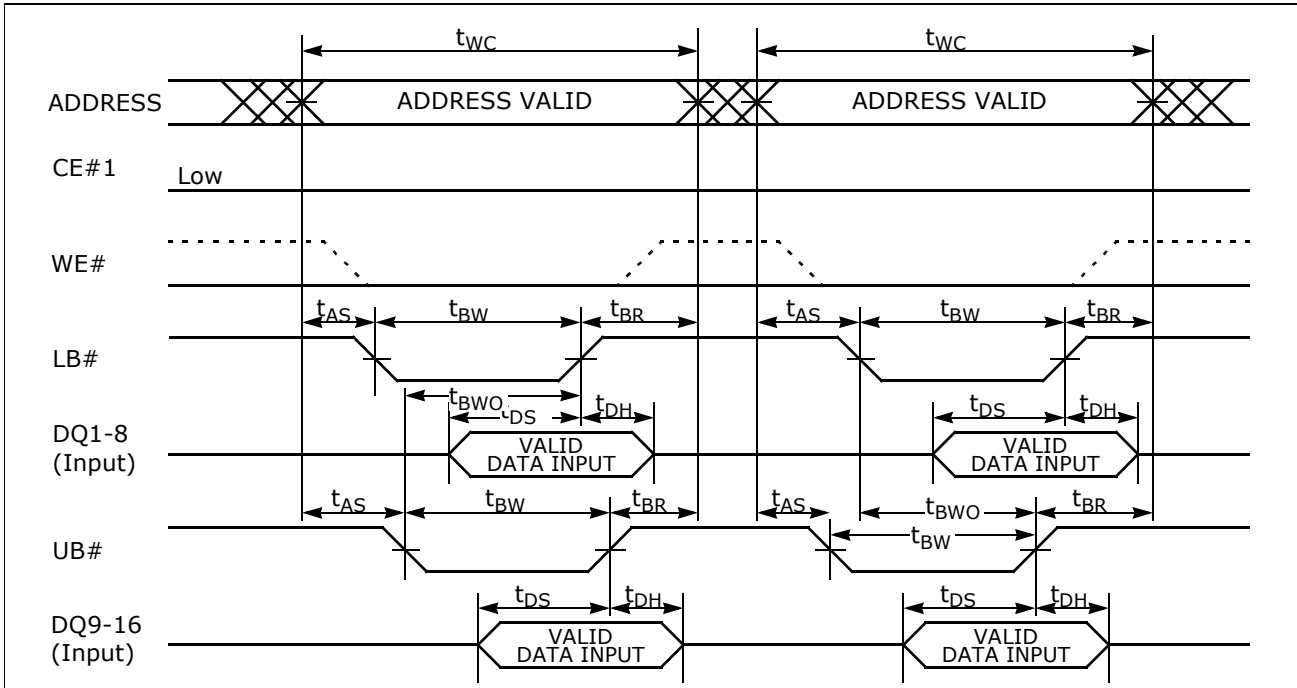

Note: This timing diagram assumes CE2=H, ADV#=L and OE#=H.

TIMING DIAGRAMS (Continued)

Asynchronous Read / Write Timing #1-1 (CE#1 Control)

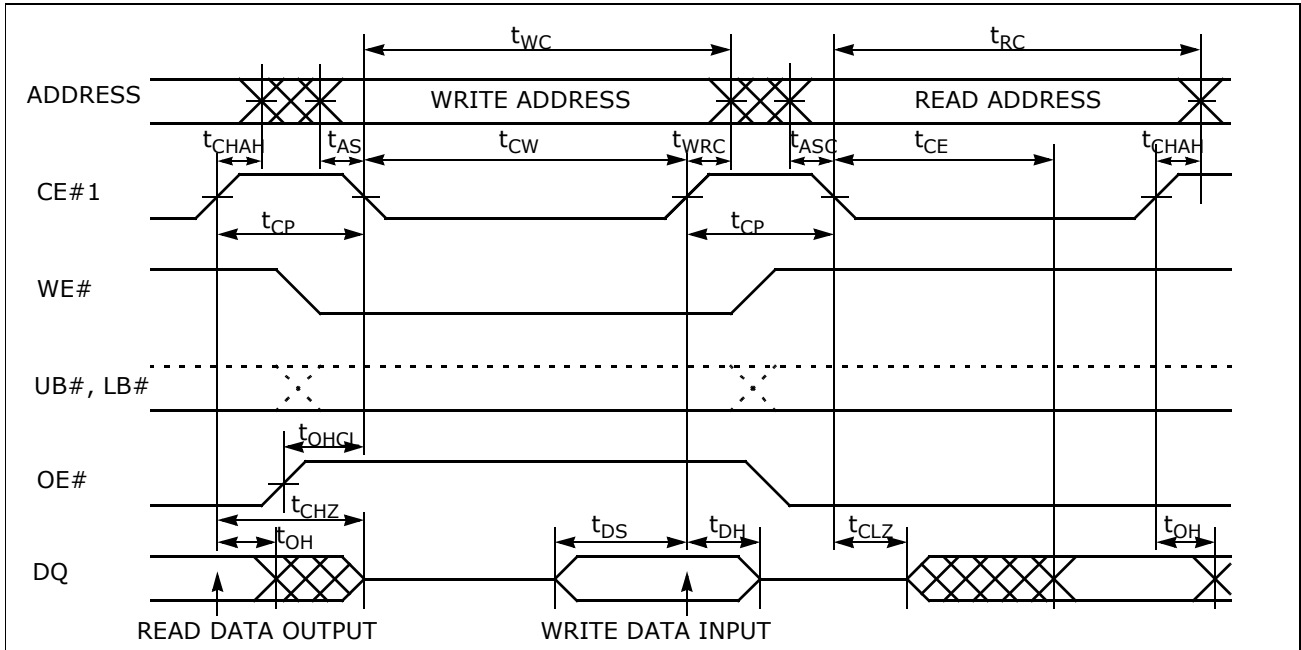

- Notes** *1: This timing diagram assumes CE2=H and ADV#=L.
 *2: Write address is valid from either CE#1 or WE# of last falling edge.

Asynchronous Read / Write Timing #1-2 (CE#1 / WE# / OE# Control)

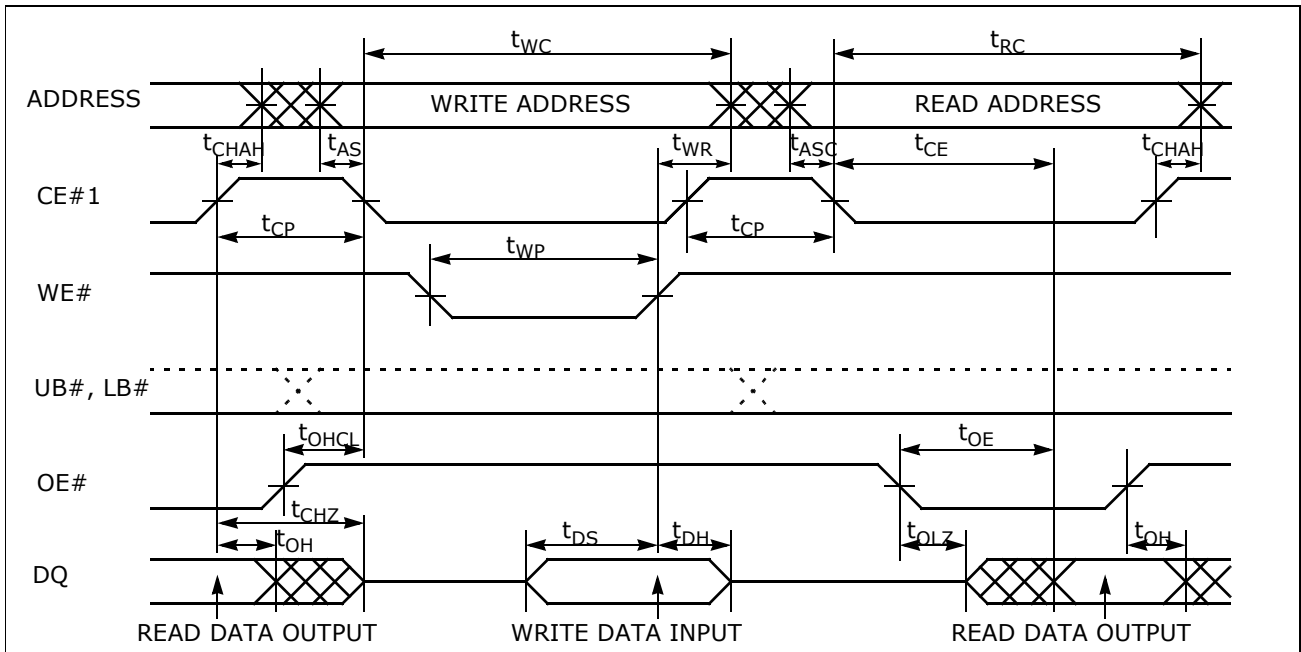

- Notes** *1: This timing diagram assumes CE2=H and ADV#=L.
 *2: OE# can be fixed Low during write operation if it is CE#1 controlled write at Read-Write-Read sequence.

TIMING DIAGRAMS (Continued)

Asynchronous Read / Write Timing #2 (OE#, WE# Control)

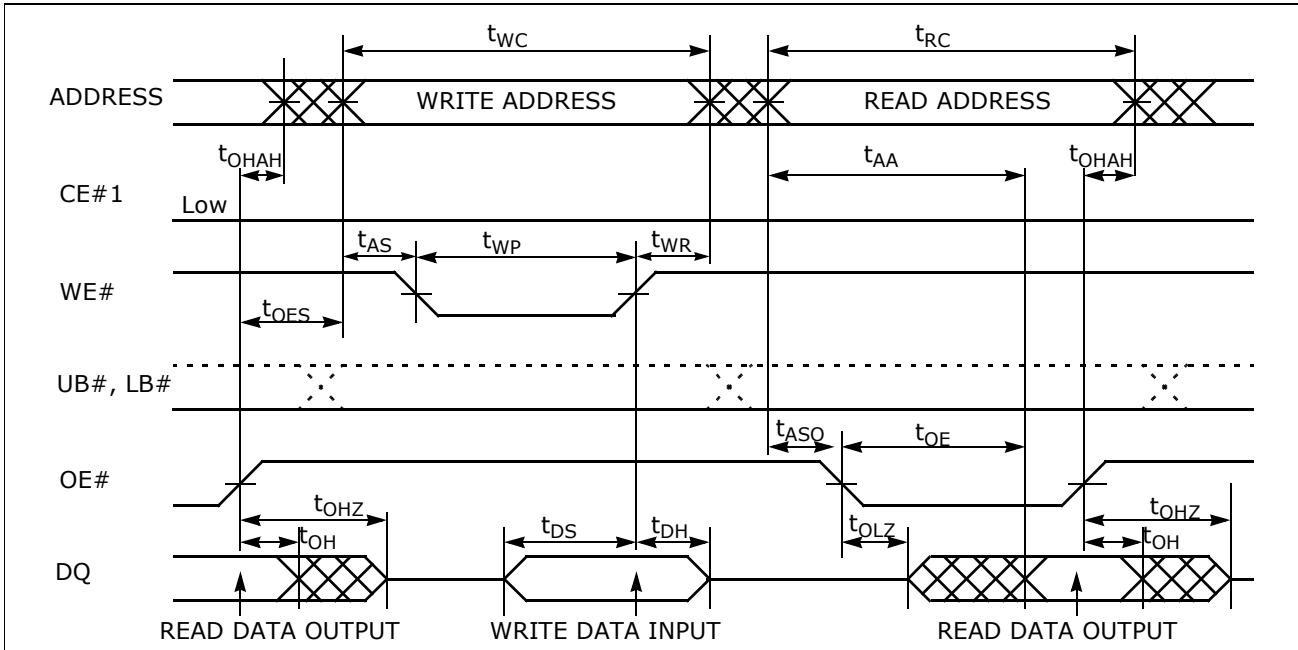

- Notes** *1: This timing diagram assumes CE2=H and ADV#=L.
 *2: CE#1 can be tied to Low for WE# and OE# controlled operation.

Asynchronous Read / Write Timing #3 (OE#, WE#, LB#, UB# Control)

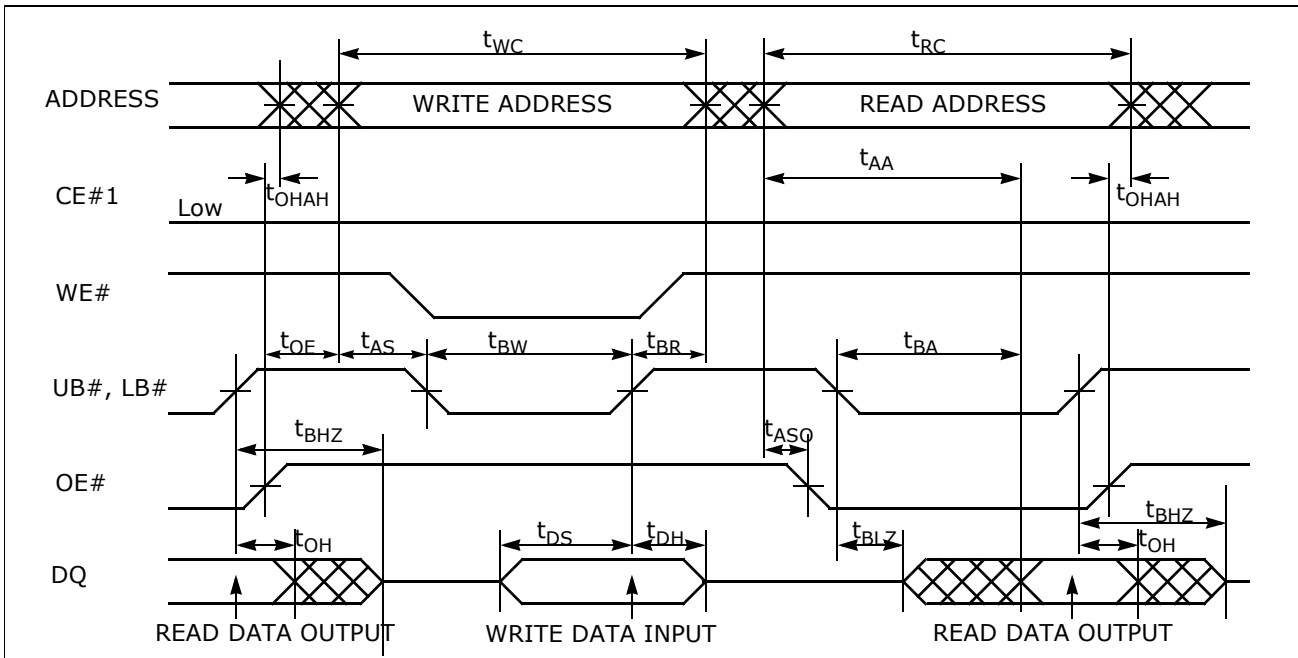

- Notes** *1: This timing diagram assumes CE2=H and ADV#=L.
 *2: CE#1 can be tied to Low for WE# and OE# controlled operation.

TIMING DIAGRAMS (Continued)

Synchronous Read Timing #2 (CE#1 Control)

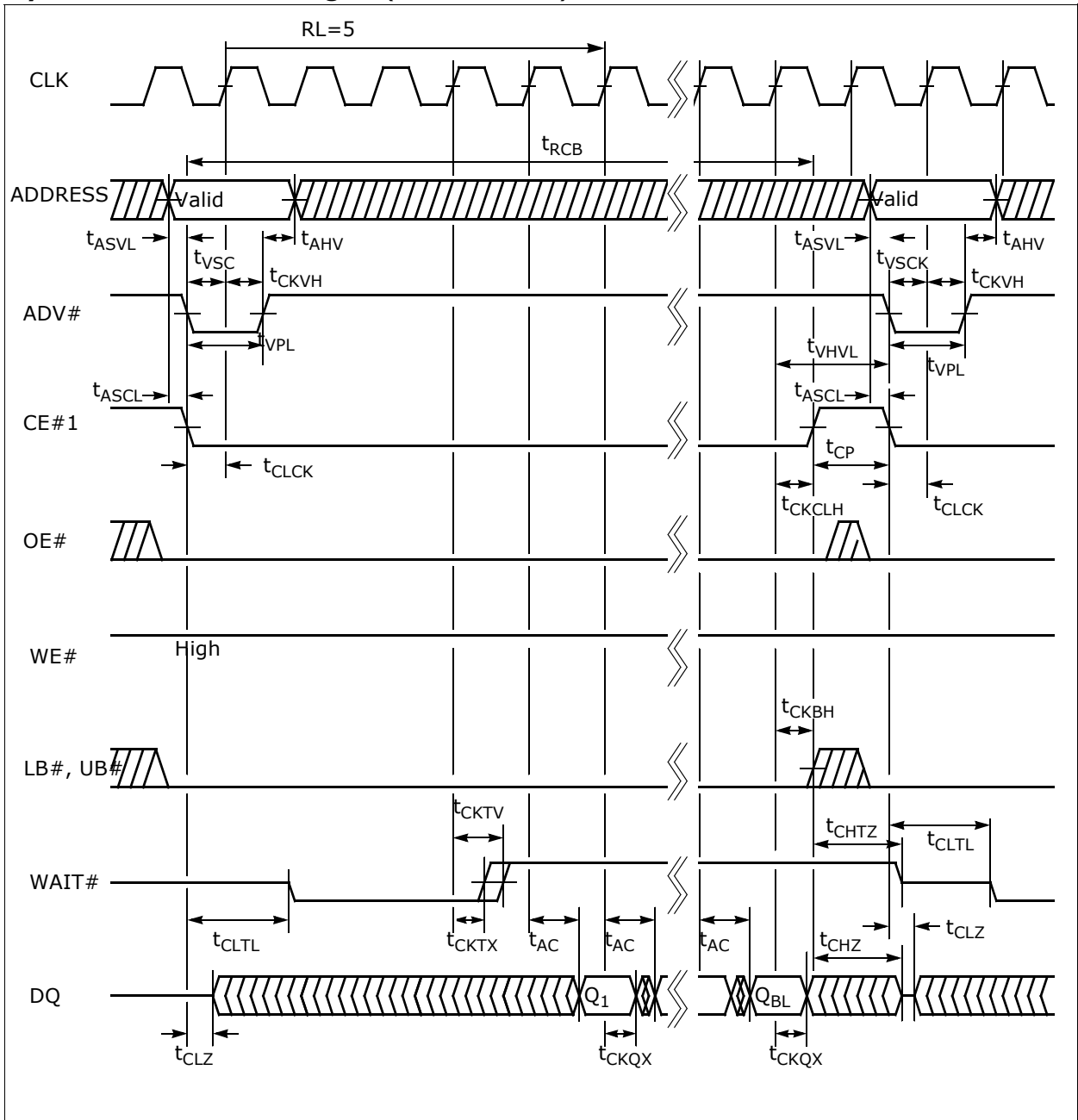

Note: This timing diagram assumes CE2=H, the valid clock edge on rising edge and BL=8 or 16.

TIMING DIAGRAMS (Continued)

Synchronous Read Timing #3 (ADV# Control)

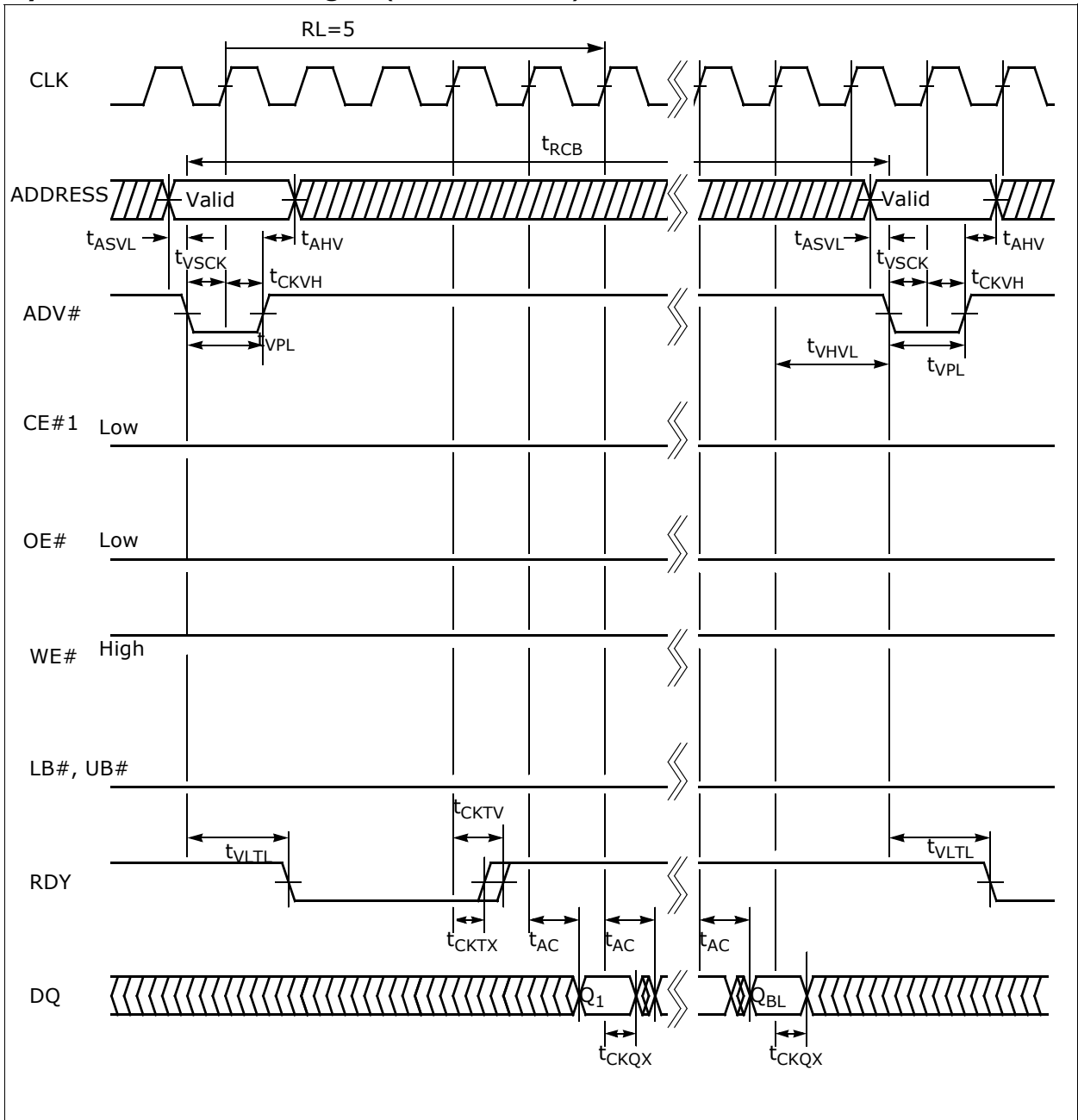

Note: This timing diagram assumes $CE2=H$, the valid clock edge on rising edge and $BL=8$ or 16 .

TIMING DIAGRAMS (Continued)

Synchronous Write Timing #1 (WE# Level Control)

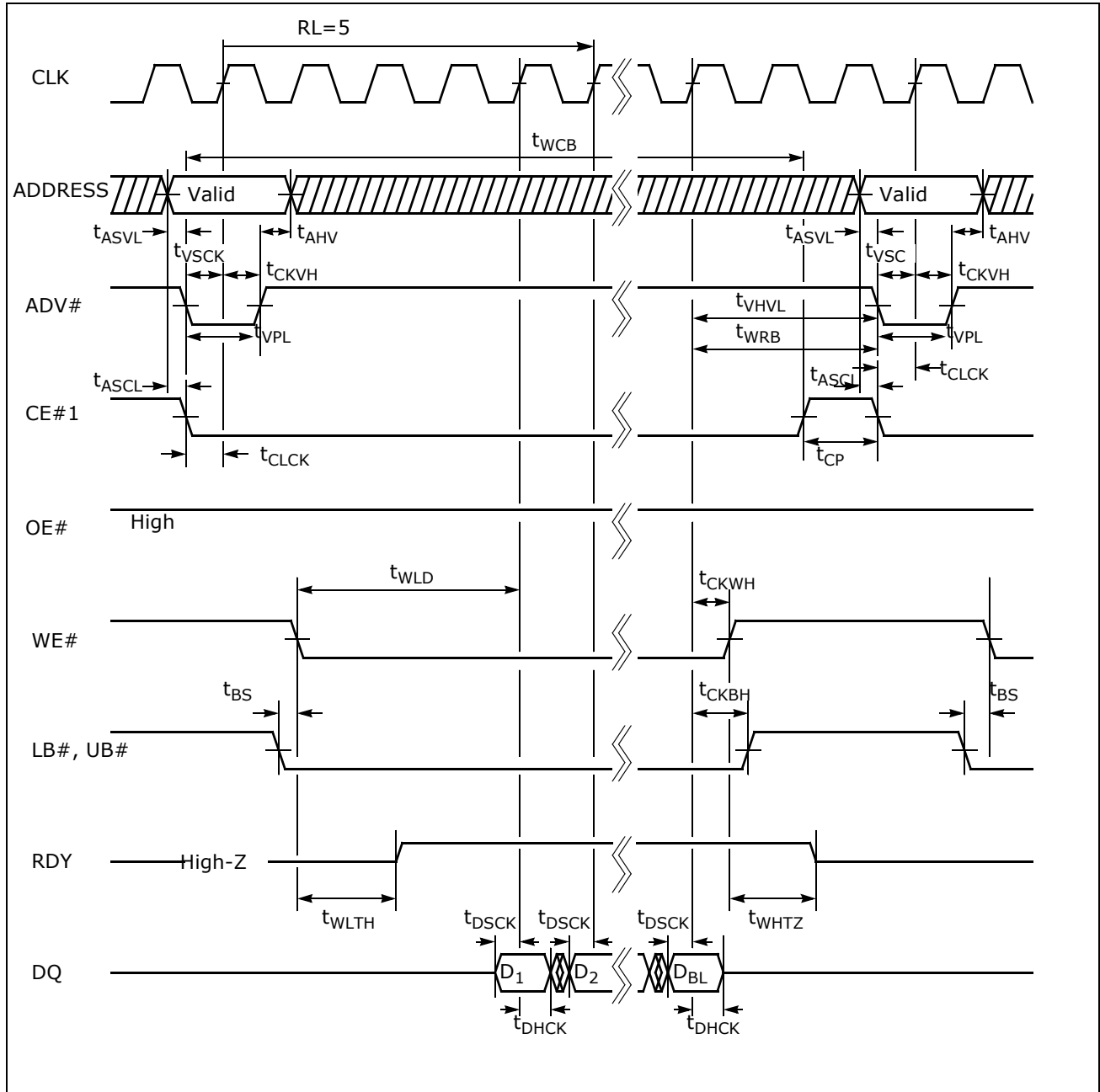

Note: This timing diagram assumes $CE2=H$, the valid clock edge on rising edge and $BL=8$ or 16 .

TIMING DIAGRAMS (Continued)

Synchronous Write Timing #2 (WE# Single Clock Pulse Control)

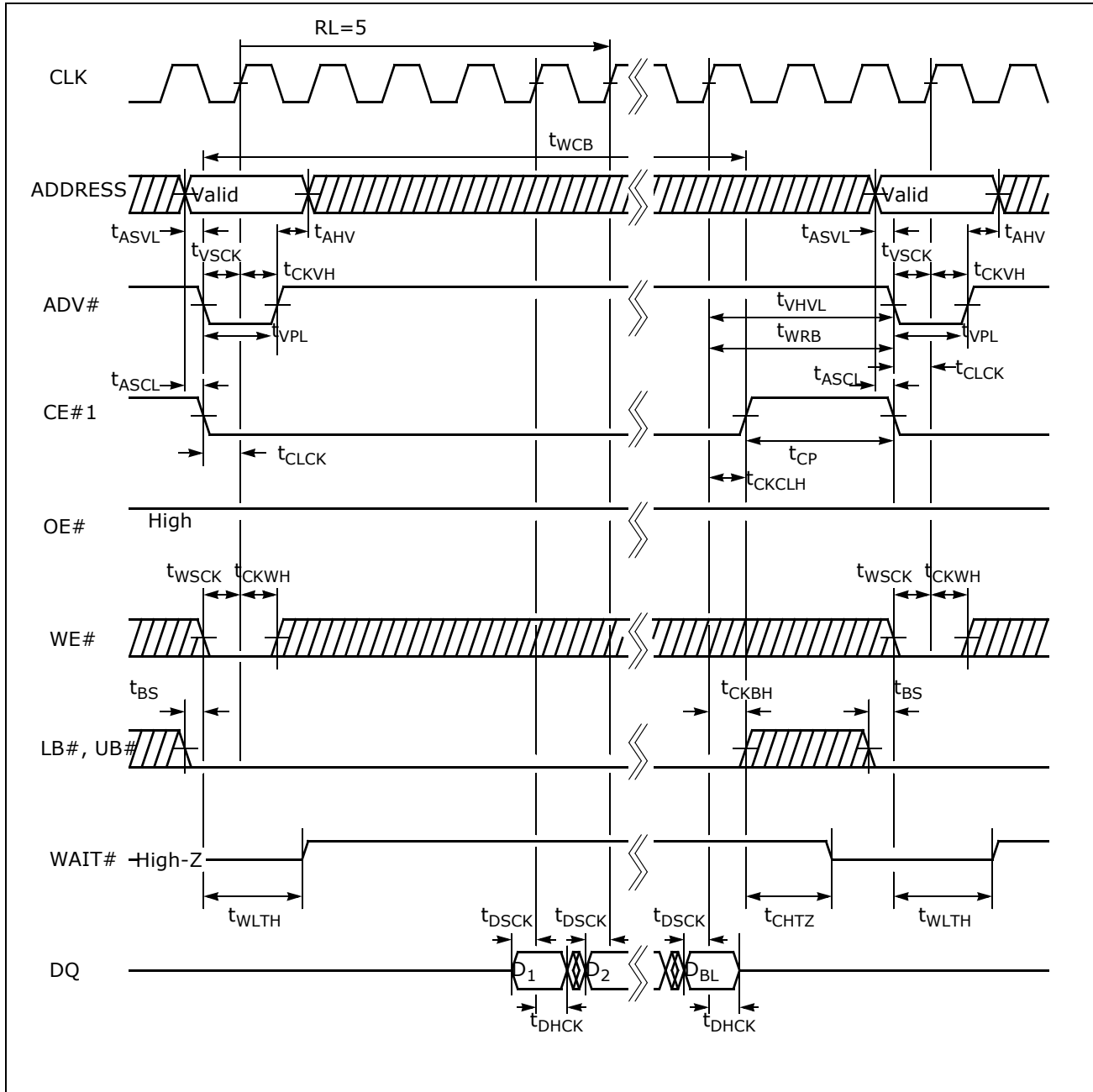

Note: This timing diagram assumes $CE2=H$, the valid clock edge on rising edge and $BL=8$ or 16 .

TIMING DIAGRAMS (Continued)

Synchronous Write Timing #3 (ADV# Control)

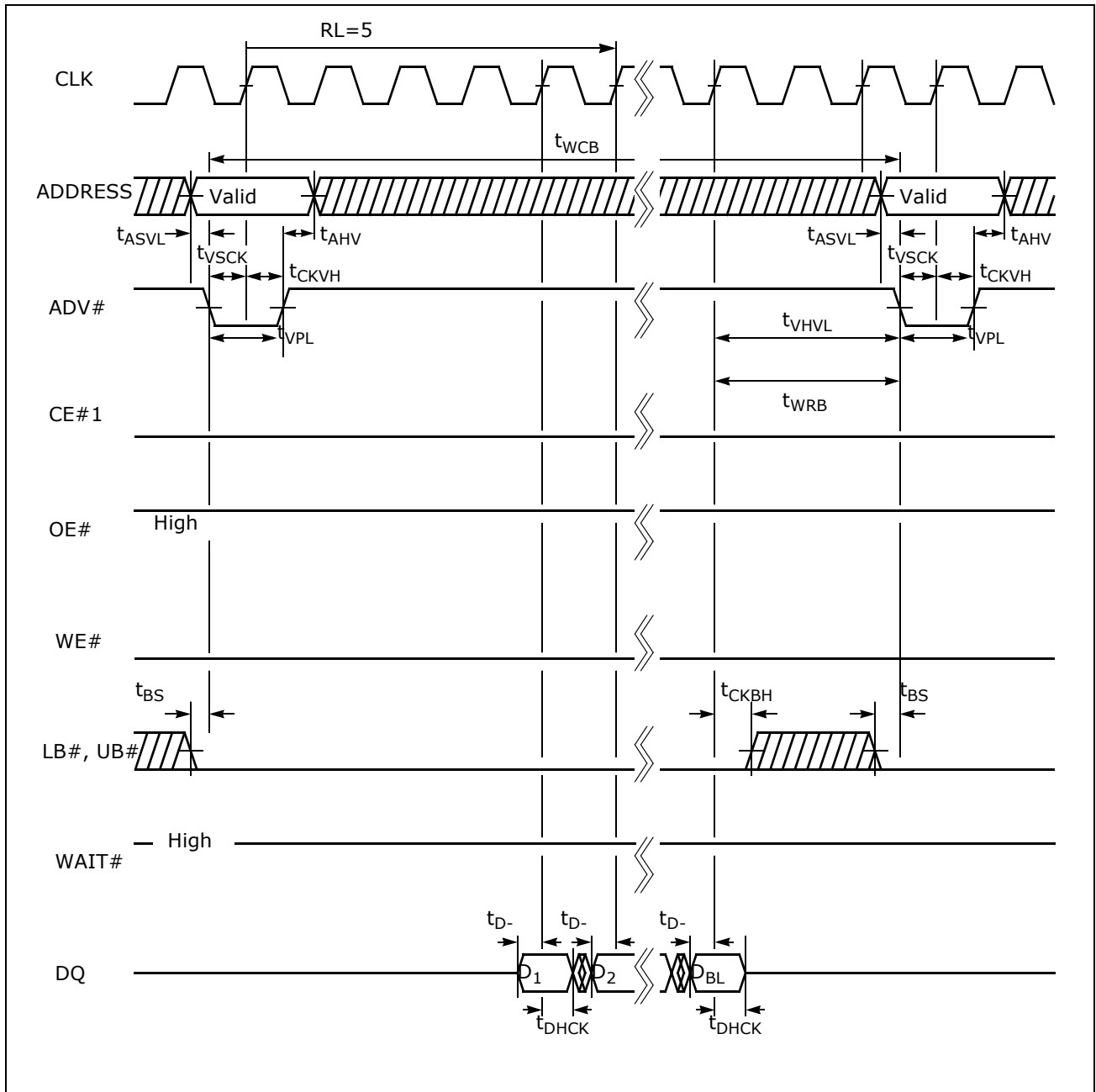

Note: This timing diagram assumes $CE2=H$, the valid clock edge on rising edge and $BL=8$ or 16 .

TIMING DIAGRAMS (Continued)

Synchronous Write Timing #4 (WE# Level Control, Single Write)

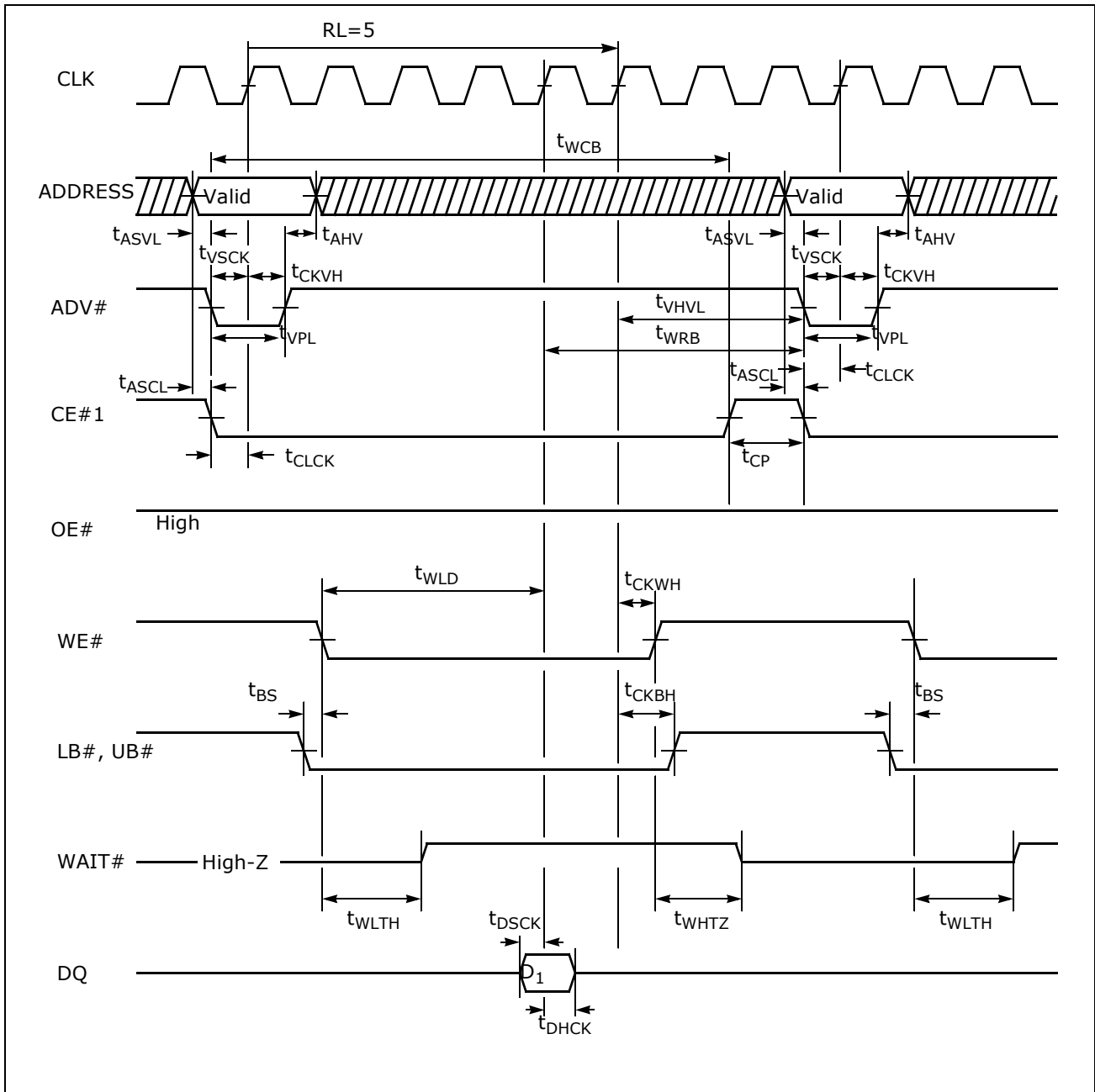

Notes *1: This timing diagram assumes $CE2=H$, the valid clock edge on rising edge and single write operation.
 *2: Write data is latched on the valid clock edge.

TIMING DIAGRAMS (Continued)

Synchronous Read to Write Timing #1(CE#1 Control)

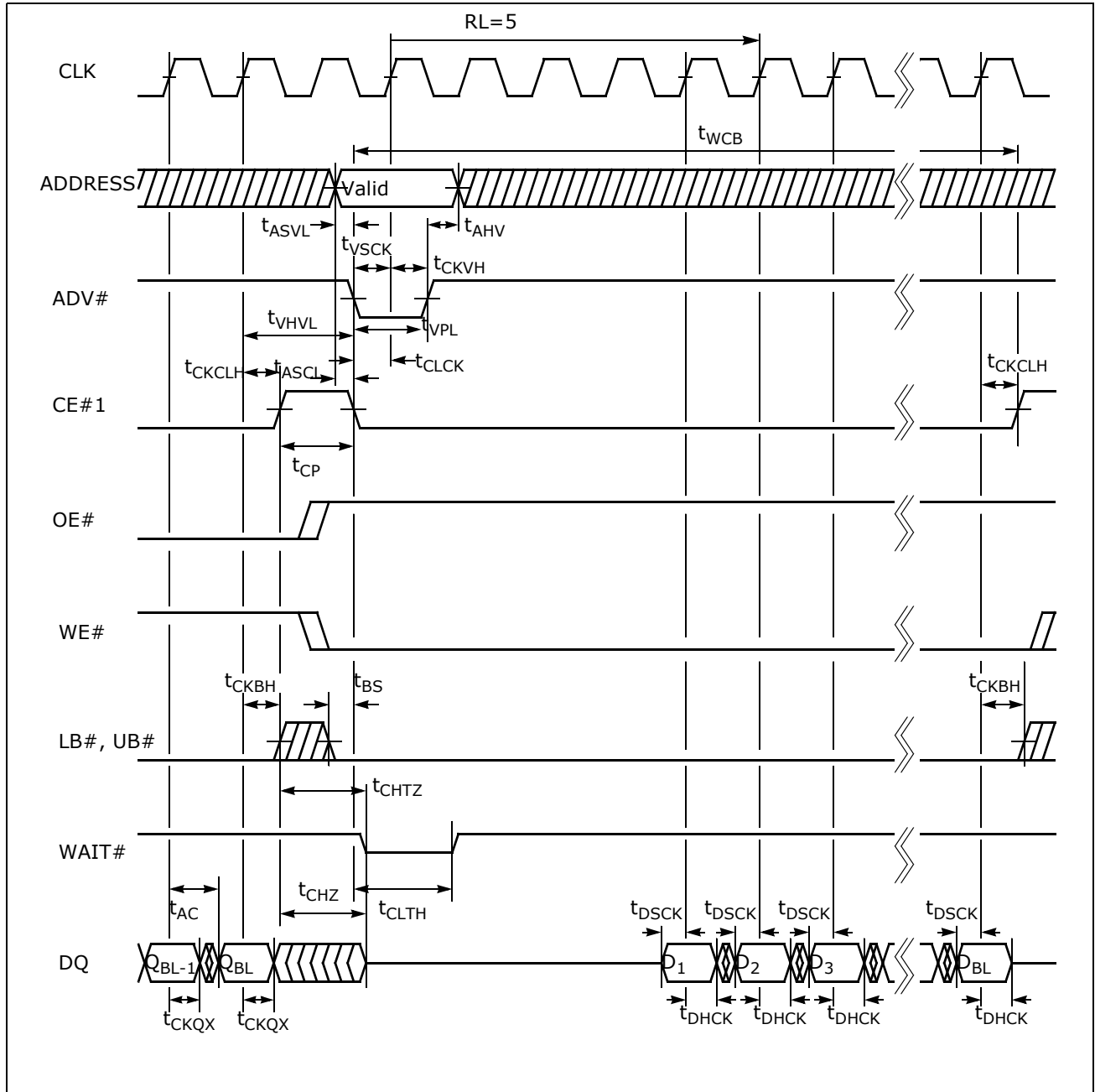

Note: This timing diagram assumes CE2=H, the valid clock edge on rising edge and BL=8 or 16.

TIMING DIAGRAMS (Continued)

Synchronous Read to Write Timing #2(ADV# Control)

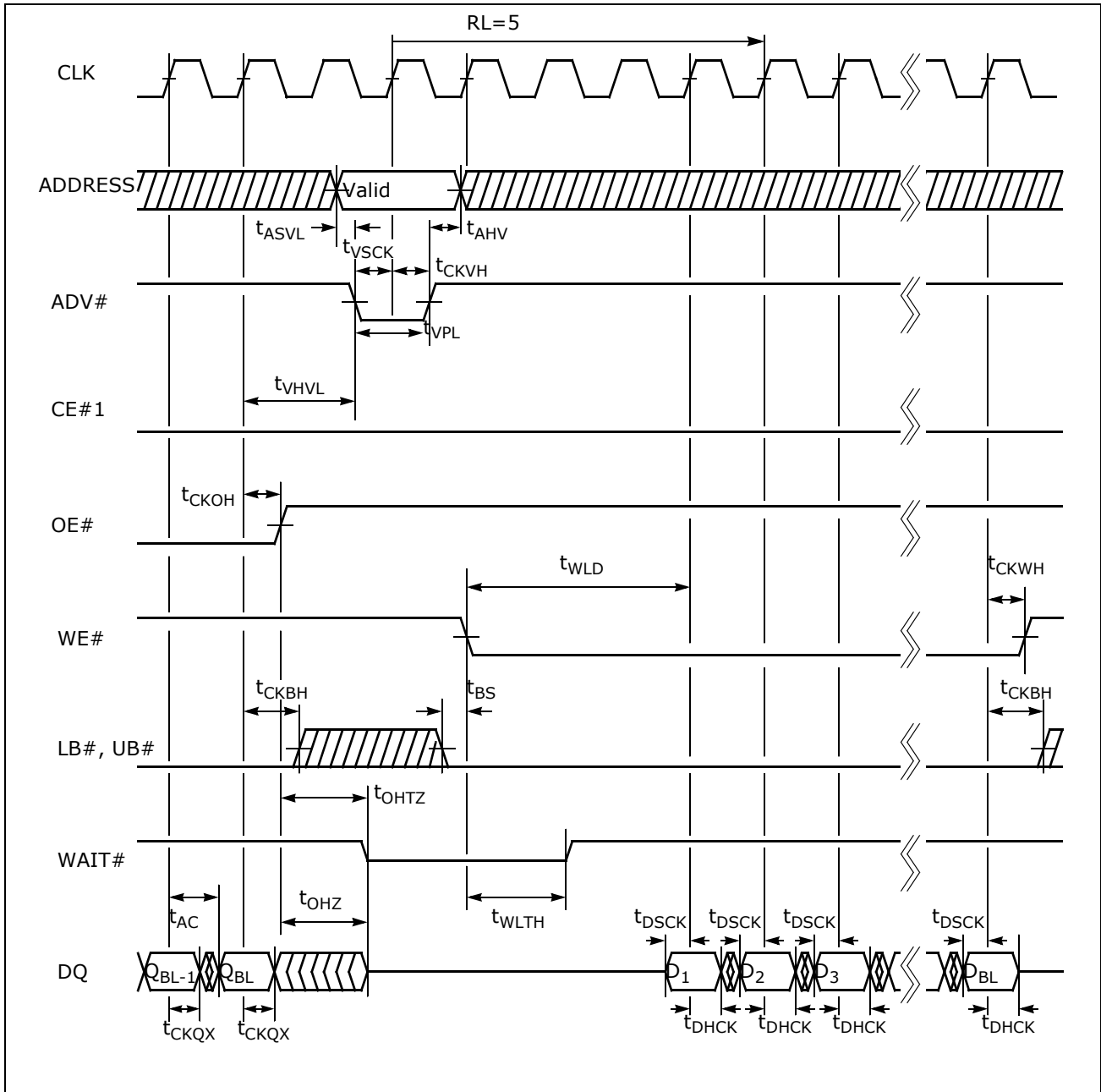

Note: This timing diagram assumes CE2=H, the valid clock edge on rising edge and BL=8 or 16.

TIMING DIAGRAMS (Continued)

Synchronous Write to Read Timing #1 (CE#1 Control)

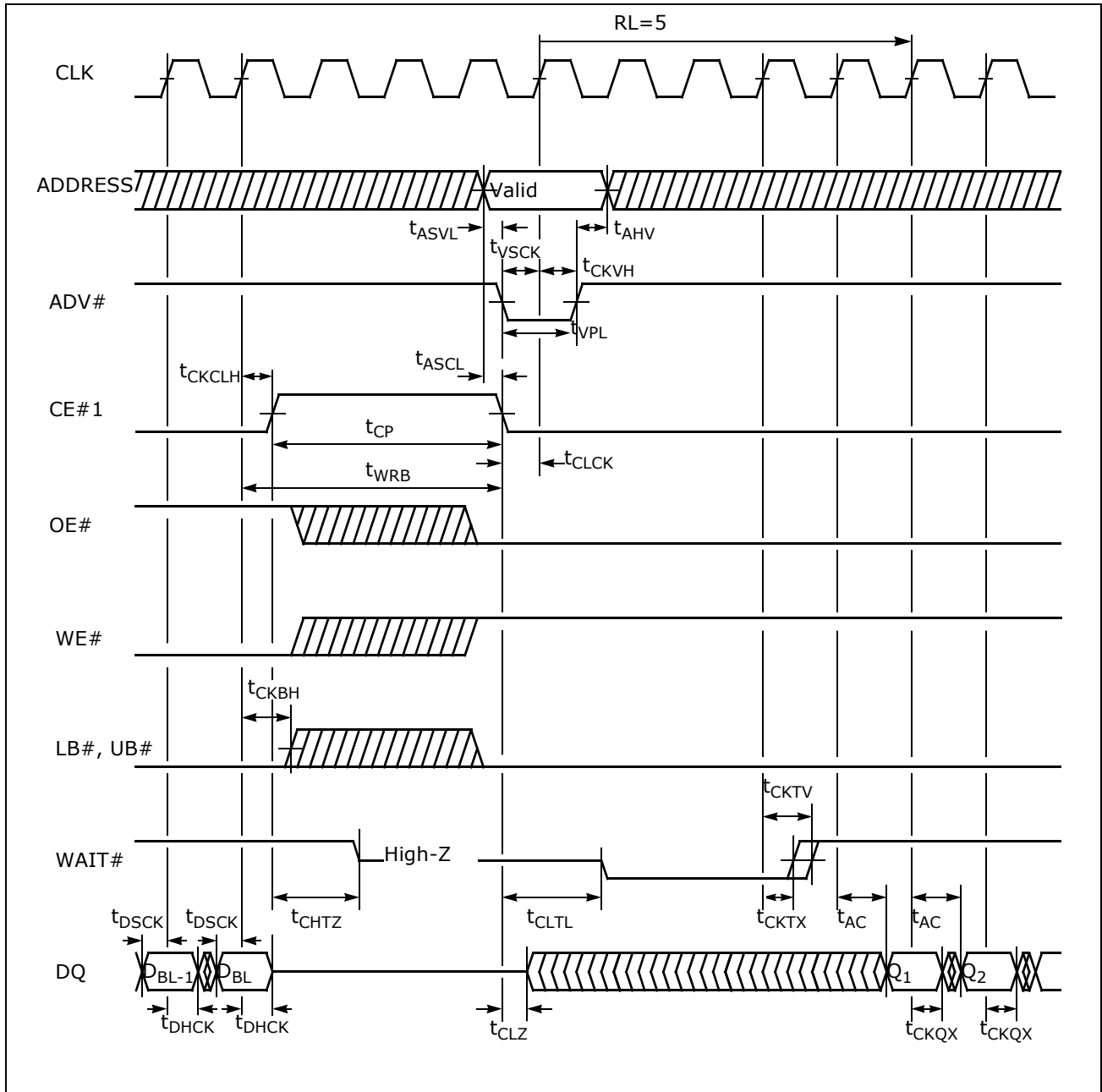

Note: This timing diagram assumes CE2=H, the valid clock edge on rising edge and BL=8 or 16.

TIMING DIAGRAMS (Continued)

POWER-UP Timing #1

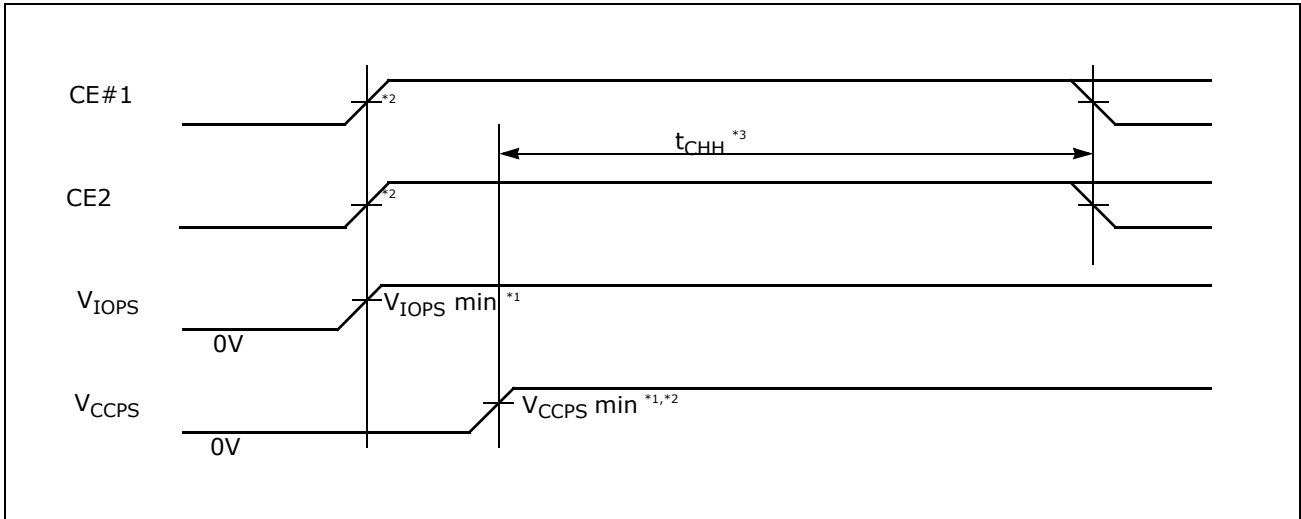

- Notes**
- *1: V_{DDQ} shall be applied and reach the specified minimum level prior to V_{DD} applied.
 - *2: The both of CE#1 and CE2 shall be brought to High together with V_{DDQ} prior to V_{DD} applied. Otherwise POWER-UP Timing#2 must be applied for proper operation.
 - *3: The t_{CHH} specifies after V_{DD} reaches specified minimum level and applicable to both CE#1 and CE2.

POWER-UP Timing #2

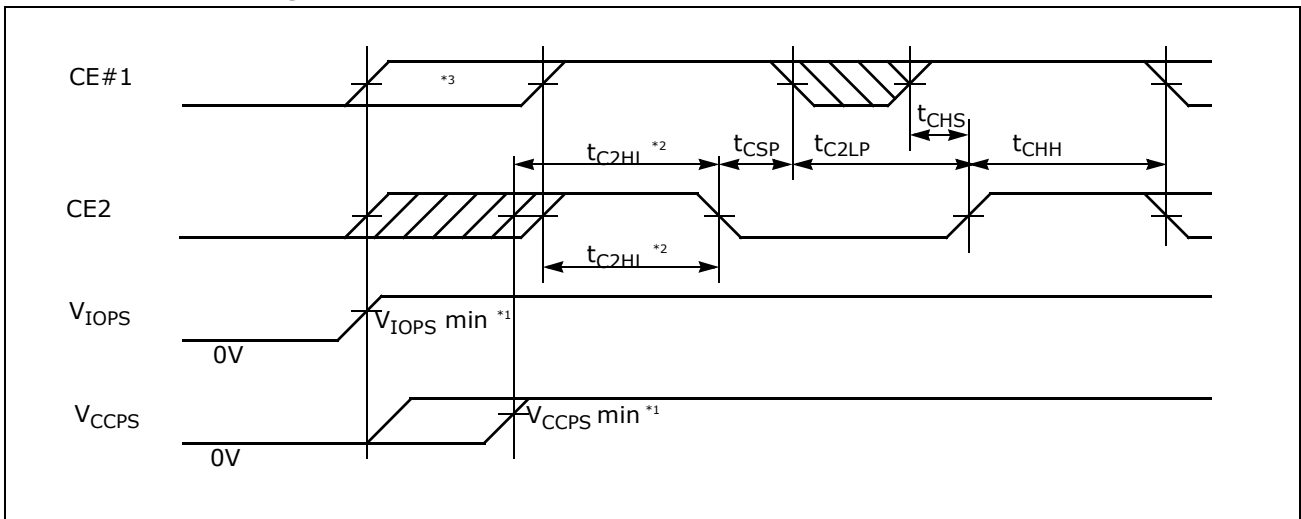

- Notes**
- *1: V_{DDQ} shall be applied and reach specified minimum level prior to V_{DD} applied.
 - *2: The t_{C2HL} specifies from CE2 Low to High transition after V_{DD} reaches specified minimum level. If CE2 became High prior to V_{DD} reached specified minimum level, t_{C2HL} is defined from V_{DD} minimum.
 - *3: CE#1 shall be brought to High prior to or together with CE2 Low to High transition.

TIMING DIAGRAMS (Continued)

POWER DOWN Entry and Exit Timing

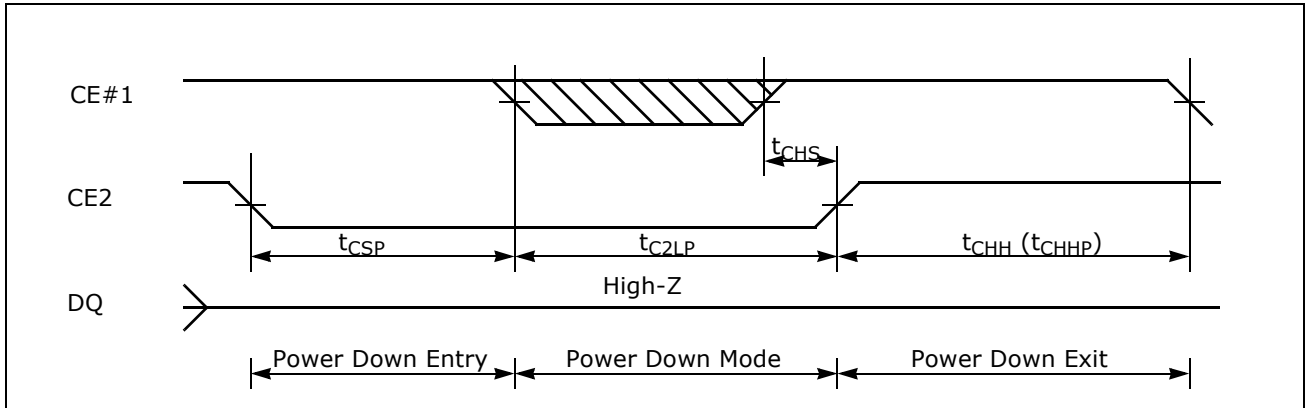

Note: This Power Down mode can be also used as a reset timing if POWER-UP timing above could not be satisfied and Power-Down program was not performed prior to this reset.

Standby Entry Timing after Read or Write

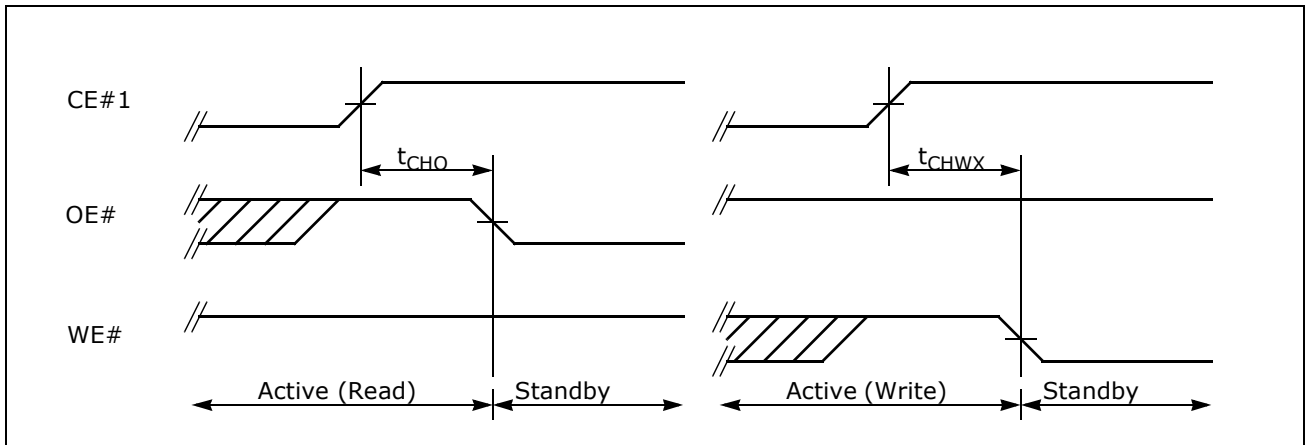

Note: Both t_{CHO} and t_{CHWX} define the earliest entry timing for Standby mode. If either of timing is not satisfied, it takes t_{RC} (min) period for Standby mode from CE#1 Low to High transition.

TIMING DIAGRAMS (Continued)

Configuration Register Set Timing #1 (Asynchronous Operation)

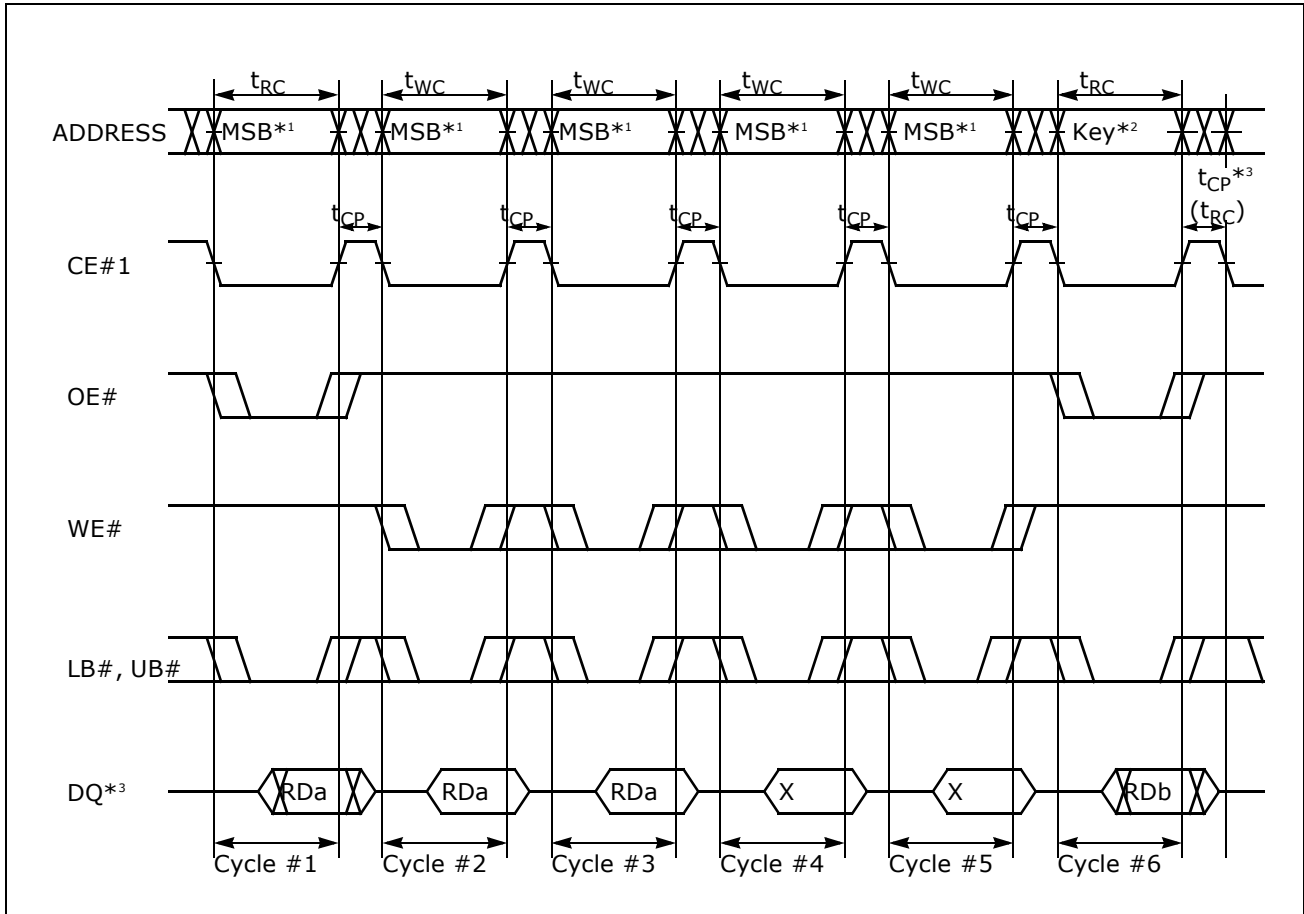

- Notes**
- *1: The all address inputs must be High from Cycle #1 to #5.
 - *2: The address key must confirm the format specified in FUNCTIONAL DESCRIPTION. If not, the operation and data are not guaranteed.
 - *3: After t_{CP} or t_{RC} following Cycle #6, the Configuration Register Set is completed and returned to the normal operation. t_{CP} and t_{RC} are applicable to returning to asynchronous mode and to synchronous mode respectively.

TIMING DIAGRAMS (Continued)

Configuration Register Set Timing #2 (Synchronous Operation)

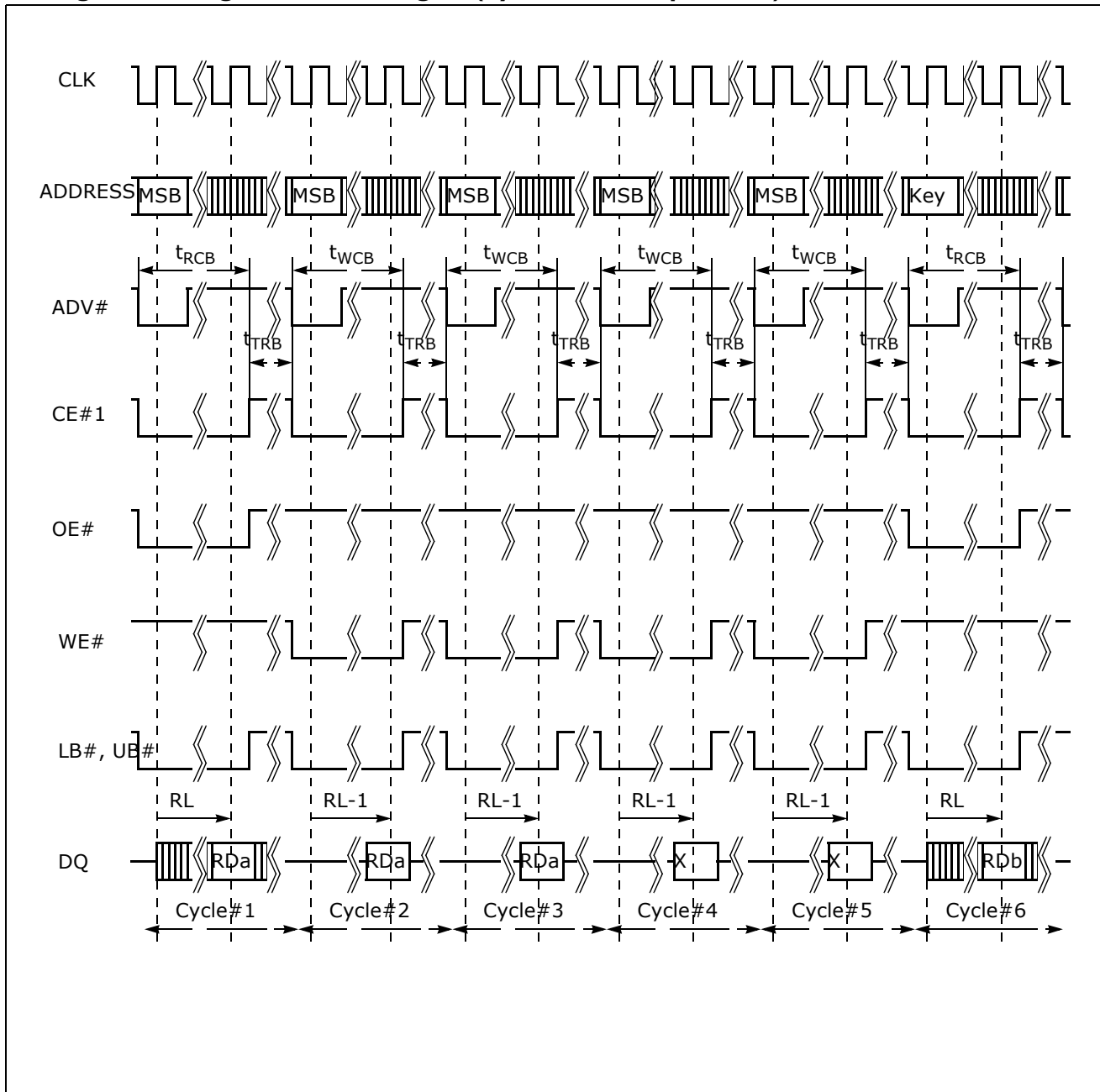

- Notes**
- *1: The all address inputs must be High from Cycle #1 to #5.
 - *2: The address key must confirm the format specified in FUNCTIONAL DESCRIPTION. If not, the operation and data are not guaranteed.
 - *3: After t_{TRB} following Cycle #6, the Configuration Register Set is completed and returned to the normal operation.

Revision Summary

Revision A (April 27, 2004)

Initial release.

Revision A+1 (June 28, 2004)

Modify

Colophon & Company name.

Trademarks and Notice

The products described in this document are designed, developed and manufactured as contemplated for general use, including without limitation, ordinary industrial use, general office use, personal use, and household use, but are not designed, developed and manufactured as contemplated (1) for any use that includes fatal risks or dangers that, unless extremely high safety is secured, could have a serious effect to the public, and could lead directly to death, personal injury, severe physical damage or other loss (i.e., nuclear reaction control in nuclear facility, aircraft flight control, air traffic control, mass transport control, medical life support system, missile launch control in weapon system), or (2) for any use where chance of failure is intolerable (i.e., submersible repeater and artificial satellite). Please note that Spansion will not be liable to you and/or any third party for any claims or damages arising in connection with above-mentioned uses of the products. Any semiconductor devices have an inherent chance of failure. You must protect against injury, damage or loss from such failures by incorporating safety design measures into your facility and equipment such as redundancy, fire protection, and prevention of over-current levels and other abnormal operating conditions. If any products described in this document represent goods or technologies subject to certain restrictions on export under the Foreign Exchange and Foreign Trade Law of Japan, the US Export Administration Regulations or the applicable laws of any other country, the prior authorization by the respective government entity will be required for export of those products.

The contents of this document are subject to change without notice. This document may contain information on a Spansion™ product under development by Spansion LLC. Spansion LLC reserves the right to change or discontinue work on any product without notice. The information in this document is provided as is without warranty or guarantee of any kind as to its accuracy, completeness, operability, fitness for particular purpose, merchantability, non-infringement of third-party rights, or any other warranty, express, implied, or statutory. Spansion LLC assumes no liability for any damages of any kind arising out of the use of the information in this document.

Copyright © 2004 Spansion LLC. All rights reserved.

Spansion™, the Spansion™ logo, MirrorBit, combinations thereof, and ExpressFlash are trademarks of Spansion LLC. Other company and product names used in this publication are for identification purposes only and may be trademarks of their respective companies.