

PART NUMBER 133-8333-401	ITEM ① BODY BRASS GOLD PL .0001 MIN OVER NICKEL PL .00005 MIN OVER COPPER PL .00005 MIN	ITEM ② CONTACT BERYLLIUM COPPER GOLD PL .00003 MIN OVER NICKEL PL .00005 MIN OVER COPPER PL .00005 MIN	ITEM ③ INSULATOR TEFLON	ITEM ④ CRIMP SLEEVE COPPER GOLD PL .00001 MIN OVER NICKEL PL .00005 MIN OVER COPPER PL .00005 MIN	ITEM ⑤ NUT BRASS GOLD PL .00001 MIN OVER NICKEL PL .00005 MIN OVER COPPER PL .00005 MIN	ITEM ⑥ LOCK WASHER PHOSPHOR BRONZE GOLD PL .00001 MIN OVER NICKEL PL .00005 MIN OVER COPPER PL .00005 MIN
-----------------------------	--	---	-------------------------------	--	--	--

DRAWING NO. C - 133-8333-401/410	
0	REVISIONS
ENGINEERING RELEASE	
1	6-29-99 R H R ECN 46497
1.0 / 8.0 LBS DISENGAGE WAS 3 LBS TYPICAL, 1.0 LB MIN	
* REVISION NUMBER FOLLOWED BY AN ALPHA *	
* CHARACTER INDICATES DRAWING CLARIF. *	
* DATE OR PART NUMBER ADDITION ONLY. *	
1a	1-2-00 R R ECO 4756D

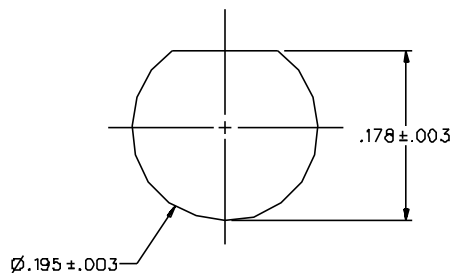

MOUNTING HOLE LAYOUT

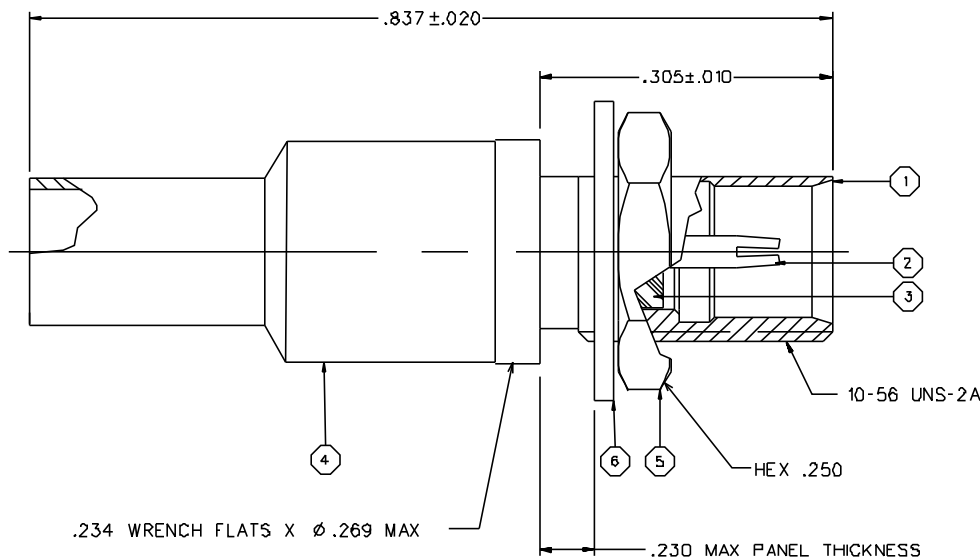

NOTES:

1. SPECIFICATIONS:

IMPEDANCE: 75 OHMS
 FREQUENCY RANGE: 0-6 GHz
 VSWR: 1.13+.04F MAX (F IN GHz)
 WORKING VOLTAGE: 335 VRMS MAX AT SEA LEVEL
 DIELECTRIC WITHSTANDING VOLTAGE: 1000 VRMS MIN AT SEA LEVEL
 INSULATION RESISTANCE: 1000 MEGOHM MIN
 CONTACT RESISTANCE:
 CENTER CONTACT - INITIAL 5 MILLIOHM MAX, AFTER ENVIRONMENTAL 8 MILLIOHM MAX
 OUTER CONDUCTOR - INITIAL 1 MILLIOHM MAX, AFTER ENVIRONMENTAL 1.5 MILLIOHM MAX
 BODY TO CABLE - INITIAL 1 MILLIOHM MAX, AFTER ENVIRONMENTAL NOT APPLICABLE
 CORONA LEVEL: 250 VOLTS MINIMUM AT 70,000 FEET
 INSERTION LOSS: .1DB MAX AT 1 GHz
 RF LEAKAGE: -.55 DB AT 2.5 GHz
 RF HIGH POTENTIAL WITHSTANDING VOLTAGE: 700 VRMS AT 4 AND 7 MHZ

MECHANICAL:

ENGAGE/DISENGAGE FORCE: 5.6 LBS MAX ENGAGEMENT
 1.0 LB MIN DISENGAGEMENT
 8.0 LBS MAX DISENGAGEMENT

CONTACT RETENTION FORCE: 2.3 LBS MIN AXIAL FORCE
 CONTACT RETENTION TORQUE: NOT APPLICABLE
 COUPLING MECHANISM RETENTION: NOT APPLICABLE
 CABLE ACCEPTABILITY: RG 179 , RG 187
 CABLE HEX CRIMP SIZE: .12B
 CABLE RETENTION: 20 LBS MIN AXIAL FORCE
 DURABILITY: 500 CYCLES MIN

ENVIRONMENTAL:

{MEETS OR EXCEEDS THE APPLICABLE PARAGRAPH OF MIL-C-39012}
 THERMAL SHOCK: MIL-STD-202, METHOD 107, CONDITION B
 OPERATING TEMPERATURE: -65 DEG C TO 165 DEG C
 CORROSION: MIL-STD-202, METHOD 101, CONDITION B
 SHOCK: MIL-STD-202, METHOD 102, CONDITION B
 VIBRATION: MIL-STD-202, METHOD 204, CONDITION B

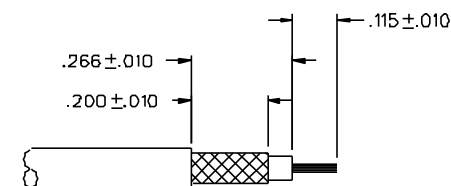

CABLE STRIP DIMENSIONS

4:1

CUSTOMER DRAWING

THIS DRAWING TO BE INTERPRETED PER ANS I Y 14.5M - 1982

"μSTATION"

COMPANY CONFIDENTIAL

TOLERANCE UNLESS OTHERWISE SPECIFIED	DRAWN BY T.A.KARI	DATE 2-19-99		299 Johnson Ave. P.O. Box 1732 Waseca, MN 56093-0832	
DECIMALS .XX	CHECKED BY TAK	DATE 7-1-99		TITLE BULKHEAD JACK ASSEMBLY STRAIGHT, RG 179 MCX 75 OHM	CODE NO.
.XXX+-.003	APPROVED BY TAK	DATE 7-1-99			
MATL	APPROVED BY RJB	DATE 7-2-99			
FINISH	RELEASE DATE 7-2-99				
			SCALE 10:1	U/W INCH	SHEET 2 OF 2