

32Bit High-Speed Up/Down Counter Board
for PCI

CNT32-8M(PCI)



* Specifications, color and design of the products are subject to change without notice.

Features

Capable of receiving two-phase and single-phase signals.

Capable of receiving pulse signals of up to 10 MHz (The minimum discernible phase difference in two-phase signal input mode is 25 nsec.)

Capable of selecting the differential line receiver input or TTL level -compatible input mode for each channel.

Protective device attached to the input circuit, providing surge protection.

Capable of discontinuity detection in differential line receiver input mode.

One control signal input pin per channel.

Capable of count values sampling at a maximum sampling rate of 20 MHz.

Supporting PCI bus mastering, enabling high-speed data transfer between the board and the PC without intervention from the CPU.

Capable of generating an interrupt, issuing an external signal, or presetting/zero-clearing the count value when it matches an arbitrary predefined value.

On-board connectors for synchronization control to easily implement operations between two or more CNT32-8M(PCI) boards or operations in synchronization with a heterogeneous board.

This product is a PCI-compliant interface board that inputs and counts pulse signals from an external device.

The board has eight channels of 32-bit up/down counters, allowing external devices such as a rotary encoder and a linear scale to be connected. Given below are examples of using the board for “detecting a position of the table of a machine tool” and “detecting a change in weight”.

The pulse signal incoming interface is differential line receiver input or TTL level -compatible input that can receive pulse signals at high speed.

When run with the dedicated support software, the application for this board can transfer data between the board and the PC at high speed using PCI bus mastering.

<Example >

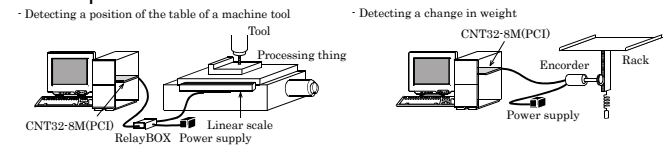

Specification

< 1 / 2 >

Item	Specification
Input	
Counter	
Channel count	8 channels
Count system	Up/down counting (2-phase/Single-phase/Single-phase Input with Gate Control Attached)
Max. count	FFFFFFFFh(binary data, 32Bit)
Input type	Differential line receiver input or TTL level input(Selectable by software)
Input signal	Phase-A/UP One x 8 channels Phase-B/DOWN One x 8 channels Phase-Z/CLR One x 8 channels
Differential line receiver input section	Element in use: Equivalent to AM26LS32(T.I) Terminal resistor: 150Ω(Can be disconnected switch.) Receiver input sensitivity: ±200mV In-phase input voltage range: ±7V Signal extension distance: 1200m(dependent on wiring environment and input frequency) *1
TTL level input section	Element in use: Equivalent to 74ALS541NS(T.I) Signal extension distance: 1.5m(dependent on wiring environment)
Response frequency	10MHz 50% duty
Digital filter	0.1μsec - 1.6384msec or not used (can be independently set for each channel.)
Timer	1msec - 6553msec 1msec unit
Counter start trigger	Software/External start input/Sampling start trigger
Counter stop trigger	Software/External start input/Sampling stop trigger
Sampling	
Sampling start trigger	Software/External start input/Sync control connectors/Count match
Sampling stop trigger	Software/External stop input/Specification number/Bus master transfer error/Sync control connectors/Count match
Sampling clock	Sampling timer/External clock input/Sync control connectors
Sampling timer	50nsec - 107sec 5nsec unit(can not be independently set for each channel.)
External sampling start signal	TTL level(Select Rise or Fall)
External sampling stop signal	TTL level(Select Rise or Fall)
External sampling clock signal	TTL level(Fall)
Response frequency	10MHz 50% duty
Control	
Control input signal type	TTL level
Control input channel	One x 8 channels
Control input signal	- Preset(Select Rise or Fall) - Zero-clear(Select Rise or Fall) - Counter start/stop(Select Rise or Fall) - General-purpose input(positive logic) Software-selected from among the above four options
Response time	100nsec (Max.)
Interrupt event	Count match(16 points), Counter error(2 points), Sampling factor(6 points), Sync control connectors error(2 points), Carry/Borrow(1 points), Timer(1 points)

*1 The frequency response at an extension of 50 m is about 10 MHz (depending on the wiring environment).
The frequency response at an extension of 100 m is about 5 MHz (depending on the wiring environment).
The frequency response at an extension of 150 m is about 1.5 MHz (depending on the wiring environment).
The frequency response at an extension of 300 m is about 1 MHz (depending on the wiring environment).
The frequency response at an extension of 600 m is about 500 KHz (depending on the wiring environment).
The frequency response at an extension of 1200 m is about 80 KHz (depending on the wiring environment)

< 2 / 2 >

Item	Specification
Output	
Control	
Control output channel	One x 8 channels
Control output signal	- Count match 0 output(one-shot pulse output) - Count match 1 output(one-shot pulse output) - Digital filter error output(one-shot pulse output) - Abnormal input error output(one-shot pulse output) - Disconnection alarm error output(one-shot pulse output) - General-purpose output(Level output) Software-selected from among the above five options (Positive/negative logic is selected with the on-board switch.)
One shot output signal amplitude	Selected between 10µsec, 100µsec, 1msec, 10msec and 100 msec (Can be set for each channel, within precision + 1µsec)
Element in use	Non-Isolated Open Collector Output: Equivalent to 74LS07NS(T.I.)
Output rating	30V 40mA
Response speed	5µsec (Max.)
TP	
Test pulse output signal	One line receiver output for each of phases-A and B (For TTL output, use the positive line receiver output.)
Element in use	Equivalent to AM26LS31(T.I.)
Frequency	100kHz
Bus master	
DMA channel	1 channel
Transfer bus width	32-Bit width
Transfer data length	8 PCI Words length(Max.)
Transfer rate	80MB/sec(Max.133MB/sec)
FIFO	1K-DWord
Scatter/Gather function	64MB
Interrupt event	Bus master event(7 points)
Synchronization	
Control output signal	Select the output signal by software when setting the synchronization slave mode.
Control input signal	Select the synchronization event by software when setting the synchronization slave mode.
Connectable number of device	16 boards including the master board
Connector used	PS-10PE-D4T1-B1 (JAE) or equivalent x 2
Common	
I/O address	Occupies 2 locations, any 32-bytets and 64-byte boundary
Power consumption	5VDC, 1A (Max.)
Operating condition	0 - 50°C, 10 - 90%RH (No condensation)
PCI bus specification	32bit, 33MHz, Universal key shapes supported *2
Dimension (mm)	176.41(L) x 106.68(H)
Weight	120g
Certification	RoHS,CE,VCCI

*2 This board requires power supply at +5V from an expansion slot (it does not work on a machine with a +3.3V power supply alone).

Board Dimensions

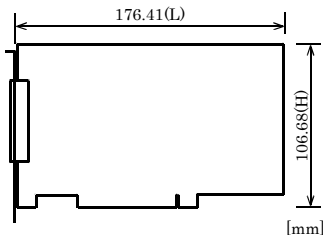

The standard outside dimension (L) is the distance from the end of the board to the outer surface of the slot cover.

Difference in bus mastering transfer rate by system configuration

When it inserts in the expansion slot of a personal computer

	Limited	Unlimited
430TX/Pentium233MHz	20	13.4
440BX/PentiumII450MHz	20	13.4
i820/PentiumIII800MHz	20	13.4
i815E/PentiumIII800MHz	20	13.4

[MHz]

"Limited" indicates that the number of transfers is specified; "Unlimited" specifies that it is not specified.

These values may not be satisfied depending on the system configuration including other boards and applications.

When CONTEC's extension unit FA-PAC (PCI) series is used

	Limited	Unlimited
430TX/Pentium233MHz	20	10
440BX/PentiumII450MHz	20	10
i820/PentiumIII800MHz	20	10
i815E/PentiumIII800MHz	20	10

[MHz]

" Limited" indicates that the number of transfers is specified; "Unlimited" specifies that it is not specified.

These values may not be satisfied depending on the system configuration including other boards and applications.

Support Software

Driver Library API-PAC(W32) (Bundled)

Windows version of counter input driver API-CNT(WDM) / API-CNT(98/PC)

[Stored on the bundled Disk driver library API-PAC(W32)]
The API-CNT(WDM) / API-CNT(98/PC) is the Windows version driver library software that provides products in the form of Win32 API functions (DLL). Various sample programs such as Visual Basic and Visual C++, etc and diagnostic program useful for checking operation is provided.

You can download the updated version from the CONTEC's Web site (<http://www.contec.com/apipac/>). For more details on the supported OS, applicable language and new information, please visit the CONTEC's Web site.

Cable & Connector

Cable (Option)

Shielded cable with double-ended connector for 96-pin half-pitch connector (Molded type) : PCB96PS-0.5P (0.5m)
: PCB96PS-1.5P (1.5m)

Flat Cable with 96-Pin Half-Pitch Connectors at Both Ends : PCB96P-1.5 (1.5m)

Shielded cables with single-ended connector for 96-pin half-pitch connector (Molded type) : PCA96PS-0.5P (0.5m)
: PCA96PS-1.5P (1.5m)

Flat Cable with One 96-Pin Half-Pitch Connector : PCA96P-1.5 (1.5m)

Connector (Option)

Half Pitch 96-Pin Female Connector Set(5Pieces)
: CN5-H96F

Accessories

Accessories (Option)

Screw Terminal Unit (M3 x 96P) : EPD-96A *1*2
Screw Terminal Unit (M3.5 x 96P) : EPD-96 *1
Terminal Unit for Cables (M2.5 x 96P) : DTP-64(PC) *1

*1A PCB96PS or PCB96PS optional cable are required separately.

*2"Spring-up" type terminal is used to prevent terminal screws from falling off.

*Check the CONTEC's Web site for more information on these options.

Packing List

Board [CNT32-8M(PCI)] ...1
First step guide ...1
Disk *1 [API-PAC(W32)] ...1
Synchronization control cable(10cm)...1
Serial number label...1
Product Registration Card & Warranty Certificate...1

*1 The Disk contains the driver software and User's Guide.

Block Diagram

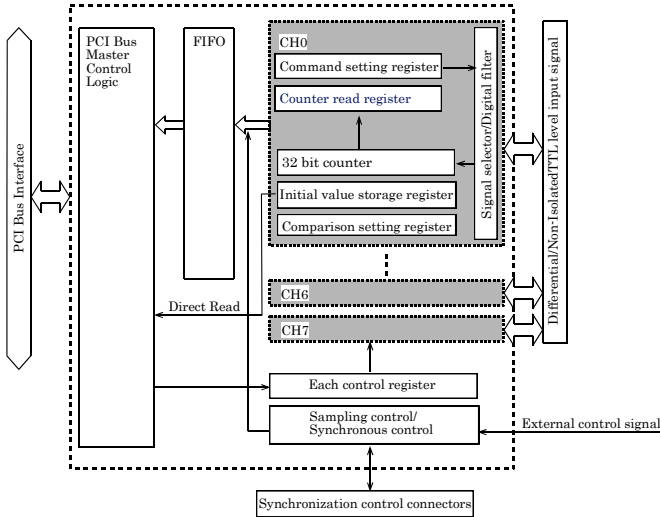

Using the On-board Connectors

Connecting a Device to a Connector

To connect an external device to this board, plug the cable from the device into the interface connector (CN1) shown below.

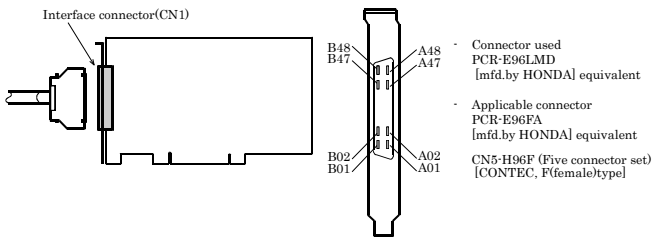

Connector Pin Assignment

This interface board is connected to an external device through the on-board connector.

Ground	GND	--B48	A48	---	GND	Ground
CH7 TTL Phase-Z input/Differential Phase-Z input+	DZ7	--B46	A46	---	DZ7	CH7 differential Phase-Z input
CH7 TTL Phase-B input/Differential Phase-B input+	DB7	--B44	A44	---	DZ7/TZ7	CH3 differential Phase-Z input+/TTL Phase-Z input
CH7 TTL Phase-A input/Differential Phase-A input+	DA7	--B42	A42	---	D3B-/T3B	CH3 differential Phase-B input+/TTL Phase-B input
Ground	GND	--B40	A40	---	D3A-/T3A	CH3 differential Phase-A input+/TTL Phase-A input
CH6 TTL Phase-Z input/Differential Phase-Z input+	DZ6	--B38	A38	---	DZ2	CH2 differential Phase-Z input
CH6 TTL Phase-B input/Differential Phase-B input+	DB6	--B36	A36	---	DZ2/TZ2	CH2 differential Phase-Z input+/TTL Phase-Z input
CH6 TTL Phase-A input/Differential Phase-A input+	DA6	--B34	A34	---	D2B-/T2B	CH2 differential Phase-B input+/TTL Phase-B input
Ground	GND	--B32	A32	---	D2A-/T2A	CH2 differential Phase-A input+/TTL Phase-A input
CH5 TTL Phase-Z input/Differential Phase-Z input+	DZ5	--B30	A30	---	D1Z-	CH1 differential Phase-Z input
CH5 TTL Phase-B input/Differential Phase-B input+	DB5	--B28	A28	---	D1Z+/T1Z	CH1 differential Phase-Z input+/TTL Phase-Z input
CH5 TTL Phase-A input/Differential Phase-A input+	DA5	--B26	A26	---	D1B-/T1B	CH1 differential Phase-B input+/TTL Phase-B input
Ground	GND	--B24	A24	---	D1A-	CH1 differential Phase-A input
CH4 TTL Phase-Z input/Differential Phase-Z input+	DZ4	--B22	A22	---	D0Z-/T0Z	CH0 differential Phase-Z input
CH4 TTL Phase-B input/Differential Phase-B input+	DB4	--B20	A20	---	D0B-/T0B	CH0 differential Phase-B input
CH4 TTL Phase-A input/Differential Phase-A input+	DA4	--B18	A18	---	D0A-/T0A	CH0 differential Phase-A input+/TTL Phase-A input
Ground	GND	--B16	A16	---	GND	Ground
CH7 control input *1	D17	--B14	A14	---	D13	CH3 control input *1
CH6 control input *1	D16	--B13	A13	---	D12	CH2 control input *1
CH5 control input *1	D15	--B12	A12	---	D11	CH1 control input *1
CH4 control input *1	D14	--B11	A11	---	D10	CH0 control input *1
External sampling start signal input	EXTSTART	--B10	A10	---	EXTCLK	External sampling clock input
External sampling stop signal input	EXTSTOP	--B09	A09	---	GND	Ground
Ground	GND	--B08	A08	---	GND	Ground
CH7 control output *2	DO7	--B07	A07	---	DO3	CH3 control output *2
CH6 control output *2	DO6	--B06	A06	---	DO2	CH2 control output *2
CH5 control output *2	DO5	--B05	A05	---	DO1	CH1 control output *2
CH4 control output *2	DO4	--B04	A04	---	DO0	CH0 control output *2
Ground	GND	--B03	A03	---	GND	Ground
Test pulse differential Phase-A output/	TPOA-	--B02	A02	---	TPOB-	Test pulse differential Phase-B output
Test pulse TTL Phase-A output/	TPOA+	--B01	A01	---	TPOB+	Test pulse differential Phase-B output+/TTL Phase-B output
Differential Phase-A output+		[96]	[48]			

*1 The control inputs can serve as the general-purpose, counter start/stop, preset, and zero-clear inputs.
*2 The control outputs can serve as the general-purpose output, count match, abnormal input error, digital filter error, and discontinuity alarm error outputs.

External Device Connection 1 - differential line receiver input -

Connecting the differential line receiver input

Use the differential line receiver input to connect the board to the line receiver output circuit of a rotary encoder or linear scale. The maximum input frequency is 10 MHz.

For use in two-phase input mode, connect both of the phase-A and phase-B inputs. For use in single-phase input mode, connect either of them. If phase-Z is not used, the input need not be connected.

For differential line receiver input mode, you can select whether to insert the terminal resistor.

Detailed description of differential line receiver input circuit

Differential line receiver input circuit and its sample connection

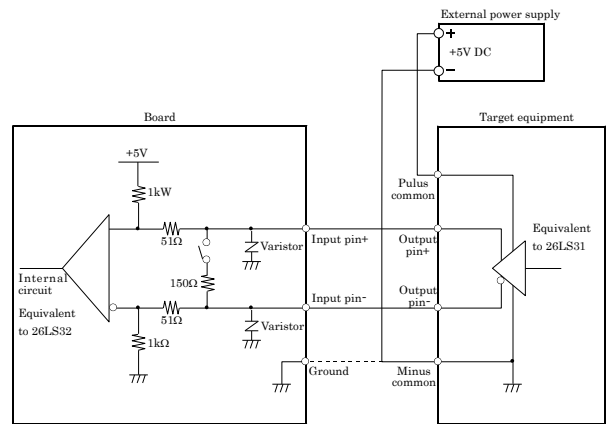

Input signal

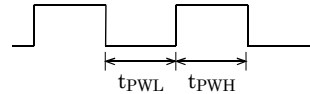

tpWH : High-level count input pulse width 50nsec (Min.)

tpWL : Low-level count input pulse width 50nsec (Min.)

CAUTION

In the input pin+, TTL level input circuit is parallel-connected.

External Device Connection 2 - TTL level input -

Connecting the TTL level input

Use the TTL level-compatible input to connect the board to the TTL level-compatible output circuit of a rotary encoder or linear scale. The maximum input frequency is 10 MHz.

For use in two-phase input mode, connect both of the phase-A and phase-B inputs. For use in single-phase input mode, connect either of them. If phase-Z is not used, the input need not be connected.

Detailed description of TTL level input circuit

TTL level input circuit and its sample connection

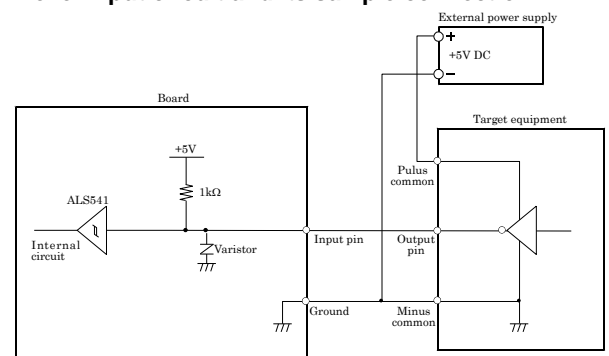

Input signal

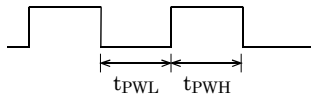

t_{pWH} : High-level count input pulse width 50nsec (Min.)
 t_{pWL} : Low-level count input pulse width 50nsec (Min.)

CAUTION

The connection cable length should be within 1.5 m. To prevent noise from causing a malfunction, arrange the connection cable as away from any other signal conductor or noise source as possible. In the input pin+, TTL level input circuit is parallel-connected.

Connecting the control signal input/output

Connection of a control input

For control signal input, the board has one pin per channel to be used to selectively start/stop or preset the counter for the channel and one pin per channel to be used to start or stop the sampling clock.

Control input circuit and its sample connection

Control input circuit(DI0 - DI7, EXTCLK, EXTSTART, EXTSTOP) and its sample connection

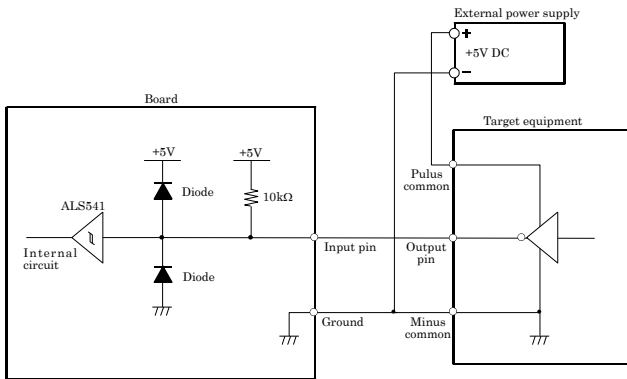

CAUTION

The connection cable length should be within 1.5 m. To prevent noise from causing a malfunction, arrange the connection cable as away from any other signal conductor or noise source as possible.

External sampling clock signal (EXTCLK)

This pin feeds the external pacer clock signal. The maximum frequency is 10 MHz.

When the sampling clock input has been set to the external clock input, sampling is performed at the falling edge of the signal at this pin.

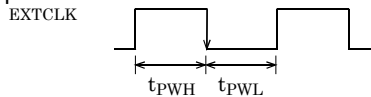

t_{pWH} : High-level clock pulse width 50nsec (Min.)
 t_{pWL} : Low-level clock pulse width 50nsec (Min.)

Other control input signals (DI0 - DI7, EXTSTART, EXTSTOP)

These signals are TTL level compatible and the trigger edge is software-programmable at either the rising or falling edge. High- and low-level hold times of at least 50 nsec are required to detect an edge of the signal.

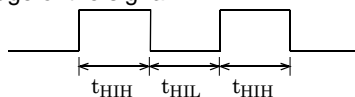

t_{HH} : High-level hold time 50nsec (Min.)
 t_{HIL} : Low-level hold time 50nsec (Min.)

Connection of a control output

The control output of the board provides the general-purpose output signal (level output) and the one-shot pulse signals that indicate hardware events such as a count match. For the signal output, positive or negative logic can be selected with SW2.

Control output circuit and its sample connection

Sample connection to Isolated output circuit (DO0 - DO7)

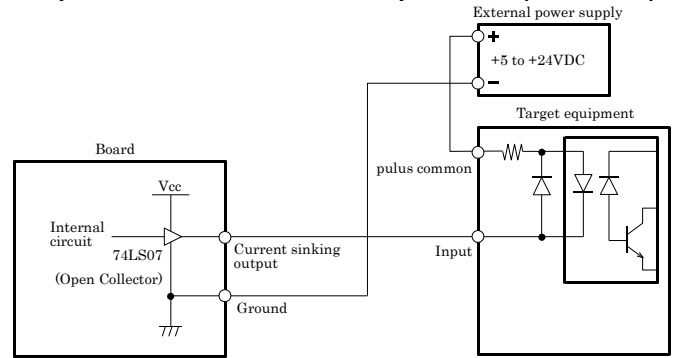

Sample connection to TTL level input circuit

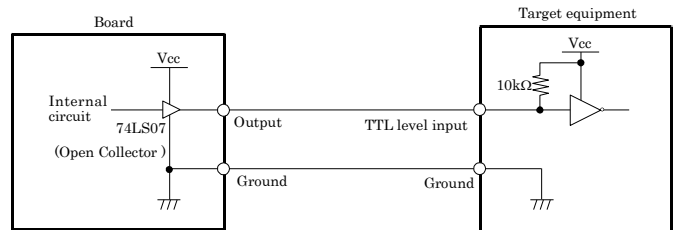

CAUTION

The output of this board has no surge voltage protector. To drive an inductive load such as a relay or lamp using this board, apply surge voltage protection to the load side. For surge voltage protection, see "Surge Voltage Countermeasures" in the this manual.