

Limit Alarms (potentiometer adj.) A-UNIT

DC ALARM

Functions & Features

- Providing SPDT relay outputs at preset DC input levels
- Dual (Hi/Lo) trip
- Energized or de-energized coil at a tripped condition selectable
- Hysteresis (deadband) adjustable
- Enclosed relays
- Relays can be powered 110 V DC
- Isolation up to 2000 V AC
- High-density mounting

Typical Applications

- Annunciator
- Various alarm applications

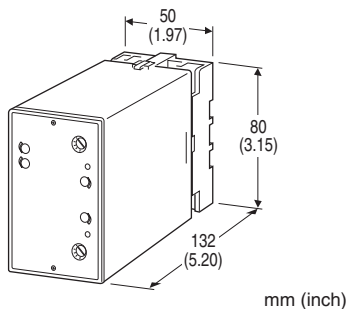

MODEL: ACV-[1][2][3]-[4][5]

ORDERING INFORMATION

- Code number: ACV-[1][2][3]-[4][5]
- Specify a code from below for each of [1] through [5].
(e.g. ACV-A113-B/Q)
- Special input range (For codes Z & 0)
- Specify the specification for option code /Q
(e.g. /C01/S01)

[1] INPUT

Current

- A: 4 - 20 mA DC (Input resistance 250 Ω)
- A1: 4 - 20 mA DC (Input resistance 50 Ω)
- B: 2 - 10 mA DC (Input resistance 500 Ω)
- C: 1 - 5 mA DC (Input resistance 1000 Ω)
- D: 0 - 20 mA DC (Input resistance 50 Ω)
- E: 0 - 16 mA DC (Input resistance 62.5 Ω)
- F: 0 - 10 mA DC (Input resistance 100 Ω)
- G: 0 - 1 mA DC (Input resistance 1000 Ω)
- H: 10 - 50 mA DC (Input resistance 100 Ω)

- J: 0 - 10 μA DC (Input resistance 1000 Ω)
- K: 0 - 100 μA DC (Input resistance 1000 Ω)
- GW: -1 - +1 mA DC (Input resistance 1000 Ω)
- FW: -10 - +10 mA DC (Input resistance 100 Ω)
- Z: Specify current (See INPUT SPECIFICATIONS)

Voltage

- 1: 0 - 10 mV DC (Input resistance 10 kΩ min.)
- 15: 0 - 50 mV DC (Input resistance 10 kΩ min.)
- 16: 0 - 60 mV DC (Input resistance 10 kΩ min.)
- 2: 0 - 100 mV DC (Input resistance 100 kΩ min.)
- 3: 0 - 1 V DC (Input resistance 1 MΩ min.)
- 4: 0 - 10 V DC (Input resistance 1 MΩ min.)
- 5: 0 - 5 V DC (Input resistance 1 MΩ min.)
- 6: 1 - 5 V DC (Input resistance 1 MΩ min.)
- 4W: -10 - +10 V DC (Input resistance 1 MΩ min.)
- 5W: -5 - +5 V DC (Input resistance 1 MΩ min.)
- 0: Specify voltage (See INPUT SPECIFICATIONS)

SETPOINT ADJUSTMENTS

- 1: Single-turn screws

[2] SETPOINT 1 OUTPUT

- 1: Hi (coil energized at alarm)
- 2: Hi (coil de-energized at alarm)
- 3: Lo (coil energized at alarm)
- 4: Lo (coil de-energized at alarm)

[3] SETPOINT 2 OUTPUT

- 1: Hi (coil energized at alarm)
- 2: Hi (coil de-energized at alarm)
- 3: Lo (coil energized at alarm)
- 4: Lo (coil de-energized at alarm)

[4] POWER INPUT

AC Power

- B: 100 V AC
- C: 110 V AC
- D: 115 V AC
- F: 120 V AC
- G: 200 V AC
- H: 220 V AC
- J: 240 V AC

DC Power

- S: 12 V DC
- R: 24 V DC
- V: 48 V DC
- P: 110 V DC

[5] OPTIONS

blank: none

/Q: With options (specify the specification)

SPECIFICATIONS OF OPTION: Q (multiple selections)

COATING (For the detail, refer to M-System's web site.)

/C01: Silicone coating

/C02: Polyurethane coating

/C03: Rubber coating

TERMINAL SCREW MATERIAL

/S01: Stainless steel

GENERAL SPECIFICATIONS

Construction: Plug-in

Connection: M3.5 screw terminals

Screw terminal: Chromated steel (standard) or stainless steel

Housing material: Flame-resistant resin (black)

Isolation: Input to output 1 to output 2 to power

Zero adjustment: -5 to +5 % (front)

Span adjustment: 95 to 105 % (front)

Setpoint adjustments: 270°-turn screwdriver adjustments (front); 0 - 100 % independently

Hysteresis (deadband) adjustments: 1 - 100 % (front)

Front LEDs: LED turns on at a tripped condition; red for output 1, green for output 2

Power ON timer: Relays de-energized for approx. 2 seconds after power is turned on.

INPUT SPECIFICATIONS

■ DC Current:

Shunt resistor attached to the input terminals (0.5 W)

Specify input resistance value for code Z.

■ DC Voltage: -300 - +300 V DC

Minimum span: 10 mV

Offset: Max. 1.5 times span

Input resistance

Span 10 - 100 mV : $\geq 10 \text{ k}\Omega$

Span 0.1 - 1 V : $\geq 100 \text{ k}\Omega$

Span $\geq 1 \text{ V}$: $\geq 1 \text{ M}\Omega$

OUTPUT SPECIFICATIONS

■ Relay Contact: 100 V AC @ 1 A ($\cos \phi = 1$)

120 V AC @ 1 A ($\cos \phi = 1$)

240 V AC @ 0.5 A ($\cos \phi = 1$)

30 V DC @ 1 A (resistive load)

Maximum switching voltage: 380 V AC or 125 V DC

Maximum switching power: 120 VA or 30 W

Minimum load: 5 V DC @ 10 mA

Mechanical life: 5×10^7 cycles

For maximum relay life with inductive loads, external protection is recommended.

Alarm Trip Operation Terminal No. in parentheses

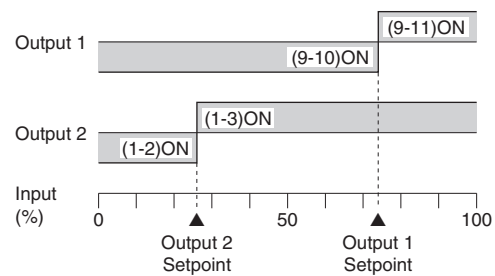

Trip Operation in Power Failure

- **Output Code: 1 & 4:** Terminals 1 - 2, 9 - 10 turn ON
- **Output Code: 2 & 3:** Terminals 1 - 3, 9 - 11 turn ON

INSTALLATION

Power input

• **AC:** Operational voltage range: rating $\pm 10 \%$, 50/60 ± 2 Hz, approx. 2 VA

• **DC:** Operational voltage range: rating $\pm 10 \%$, or 85 - 150 V for 110 V rating (ripple 10 % p-p max.) approx. 2 W (80 mA at 24 V)

Operating temperature: -5 to +60°C (23 to 140°F)

Operating humidity: 30 to 90 %RH (non-condensing)

Mounting: Surface or DIN rail

Weight: 450 g (0.99 lb)

PERFORMANCE in percentage of span

Trip point repeatability: $\pm 0.5 \%$

Temp. coefficient: $\pm 0.05 \%/^{\circ}\text{C}$ ($\pm 0.03 \%/^{\circ}\text{F}$)

Response time: ≤ 0.5 sec. (0 - 100 % at 90 % setpoint)

Line voltage effect: $\pm 0.1 \%$ over voltage range

Insulation resistance: $\geq 100 \text{ M}\Omega$ with 500 V DC

Dielectric strength: 2000 V AC @1 minute (input to output 1 to output 2 to power to ground)

EXTERNAL VIEW

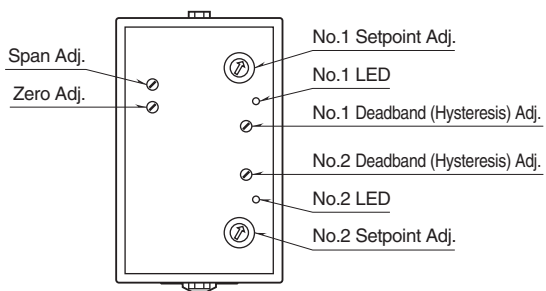

EXTERNAL DIMENSIONS unit: mm (inch)

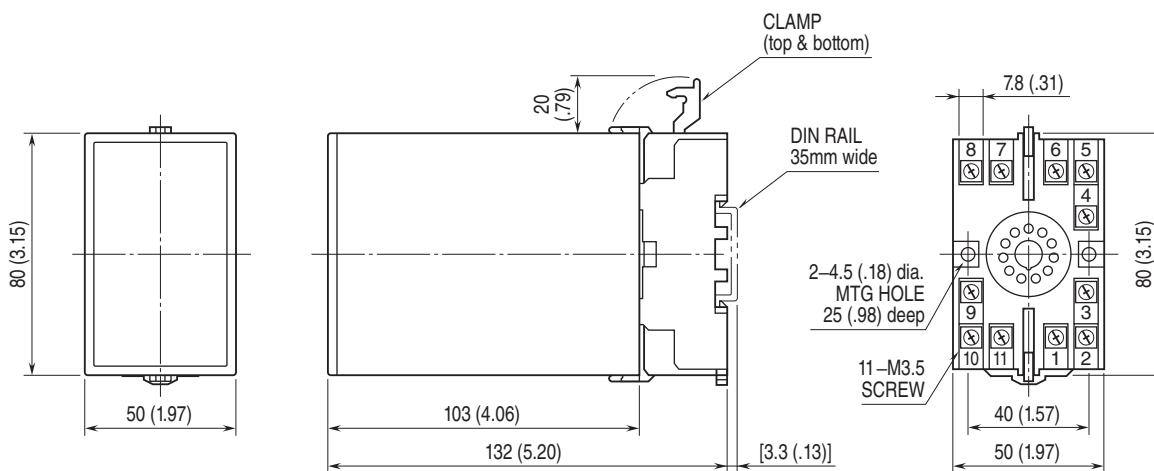

• When mounting, no extra space is needed between units.

TERMINAL ASSIGNMENTS unit: mm (inch)

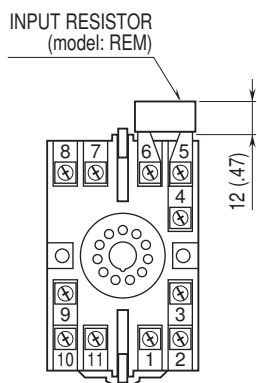

Input shunt resistor attached for current input.

SCHEMATIC CIRCUITRY & CONNECTION DIAGRAM

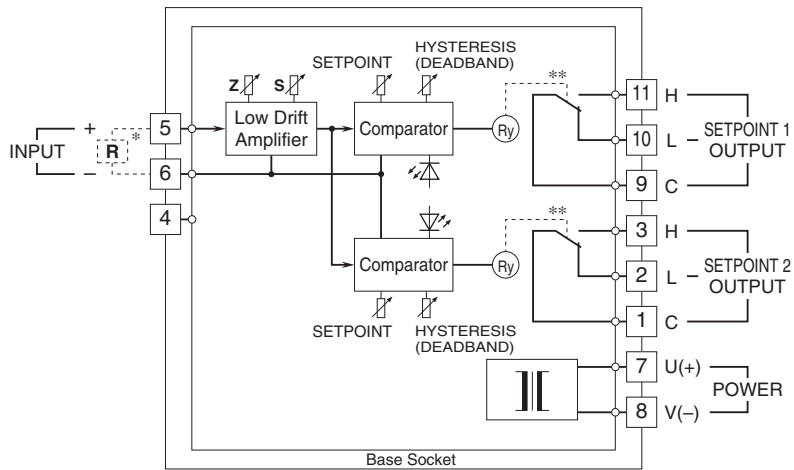

* Input shunt resistor attached for current input.

**Relay status for output codes "1" & "4", at power OFF.

■ Relay Protection

• AC Powered

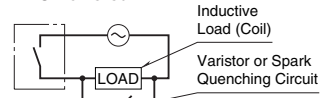

• DC Powered

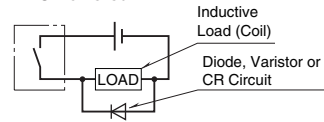

Specifications are subject to change without notice.