



LEOPARD IMAGING INC

LI-IMX224-GMSL2-xxxH

Data Sheet

Key Features

- Sony Diagonal 6.09 mm (Type 1/3) CMOS Image Sensor IMX224
- Optical format: 1/3"
- Number of active pixels: 1280H x 960V
- Pixel size: 3.75 μm x 3.75 μm
- Output 12 bit Raw data
- 27MHz clock input
- Support 12V Power
- Lens: FOV H 50 / 100
- GMSL2 Serializer
- Connector: FAKRA Z TYPE
- Water proof: IP67 (Up to IP69K)
- Operation Temp: -30 ~ 85 °C
- Storage Temp: -40 ~ 85 °C
- Size: 30 x 30 x 29.2 mm
- Weight: 45 g
- Part#: **LI-IMX224-GMSL2-xxxH**



Application

- Automotive ADAS
- Automotive Rear View or Backup

Dimensions

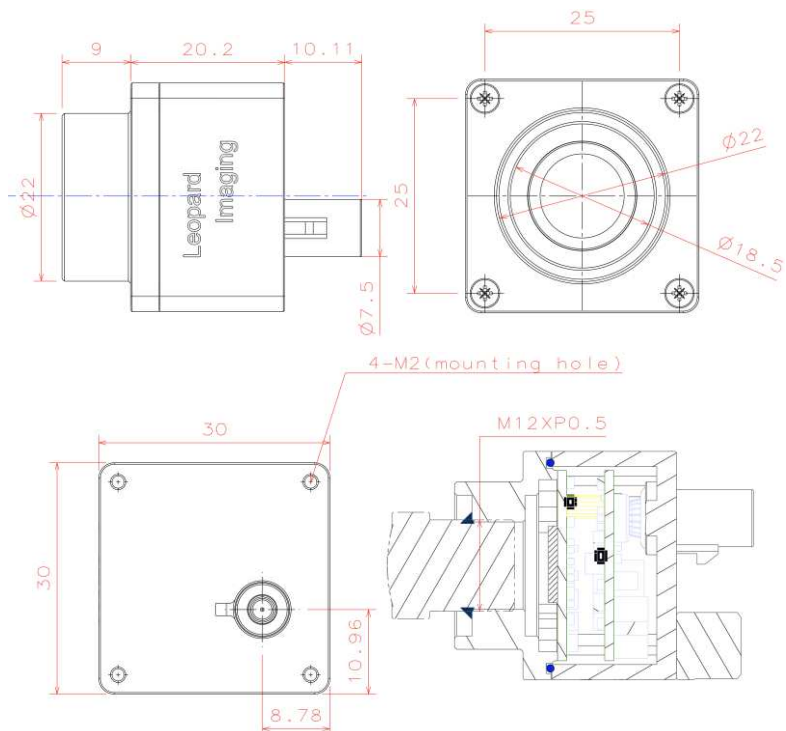

Leopard Imaging Inc.

1130 Cadillac Ct., Milpitas, CA 95035, USA
Phone: +1-408-263-0988
Fax: +1-408-217-1960
Email: sales@leopardimaging.com
Website: www.leopardimaging.com

BOM

#	Name	SPEC	QTY/SET
1	Lens	M12 lens	1
2	Screw	M2*8 cross flat head black ZINC	4
3	Shell 2	AL6061-T6 BLACK Anodizing	1
4	Sealing ring	Silicon rubber, White	1
5	LI-IMX224-MIPI-FKR	IMX224 sensor board	1
6	Copper pillar	M2*5+3	2
7	LI-GMSL2-FKR	GMSL2 board	1
8	O ring	6.5*1.5 Silicon rubber Red	1
9	Screw	M2*4 cross pan head black ZINC	2
10	Shell 1	AL6061-T6 BLACK Anodizing	1

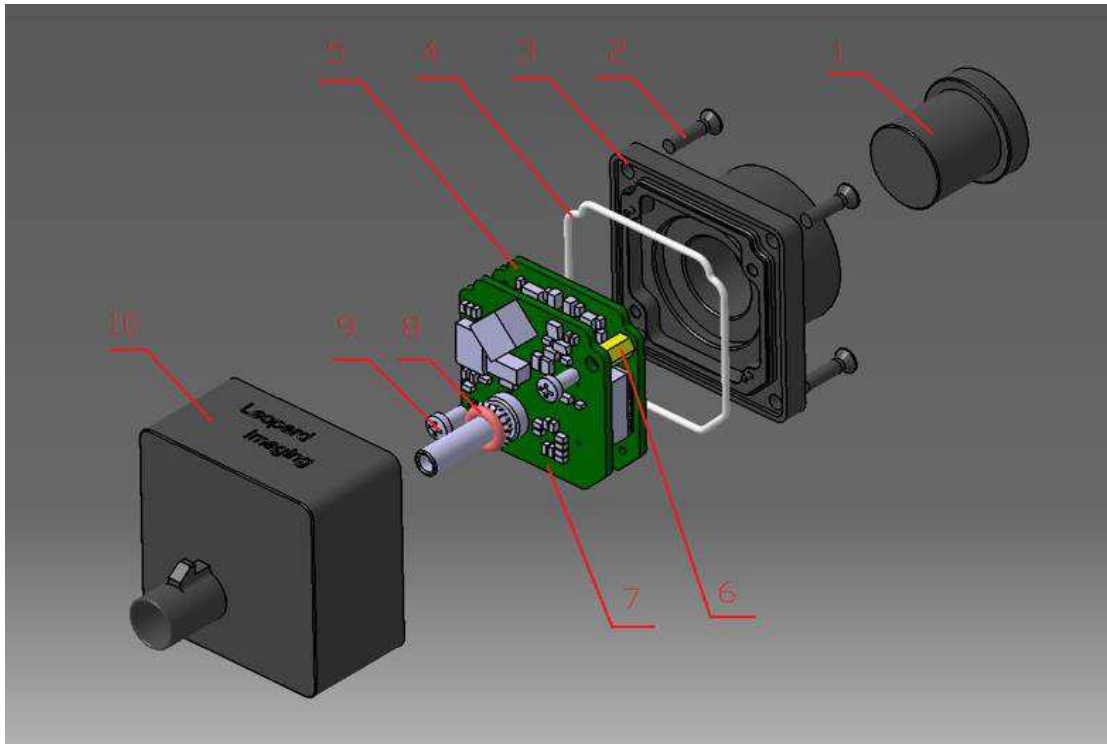

Leopard Imaging Inc.

1130 Cadillac Ct., Milpitas, CA 95035, USA
 Phone: +1-408-263-0988
 Fax: +1-408-217-1960
 Email: sales@leopardimaging.com
 Website: www.leopardimaging.com

Camera boards Dimensions

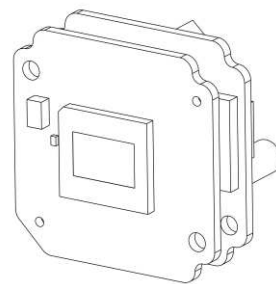
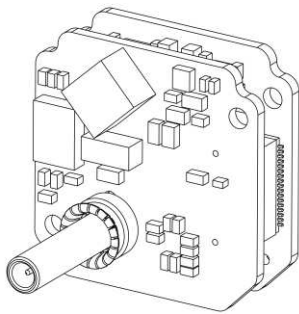
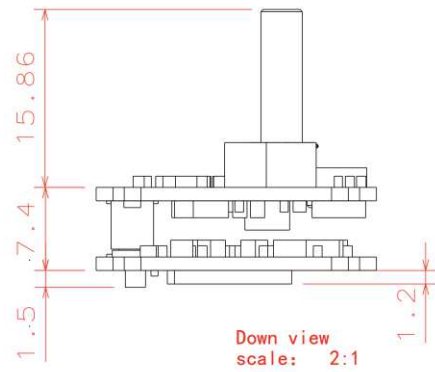
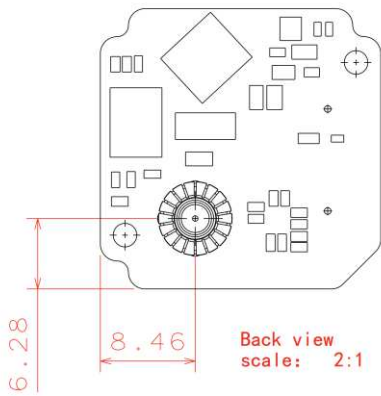
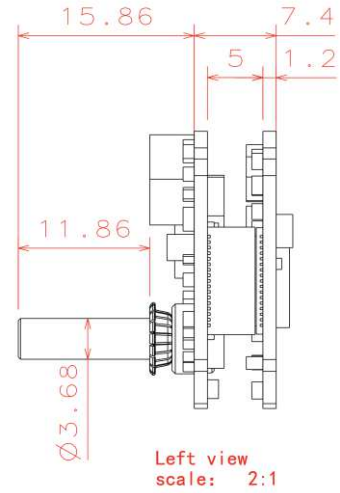
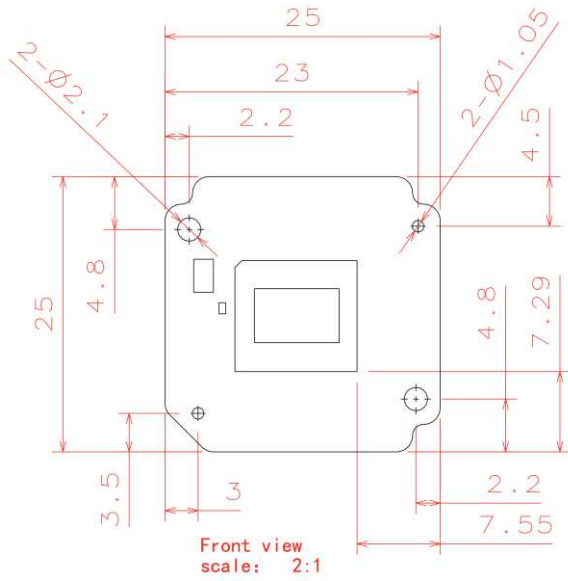

Leopard Imaging Inc.

1130 Cadillac Ct., Milpitas, CA 95035, USA
 Phone: +1-408-263-0988
 Fax: +1-408-217-1960
 Email: sales@leopardimaging.com
 Website: www.leopardimaging.com

Water Proof

- Metal Housing
- Water-proof M12 lens
- Sealed Gasket (White)
- Sealed O-ring (Red)

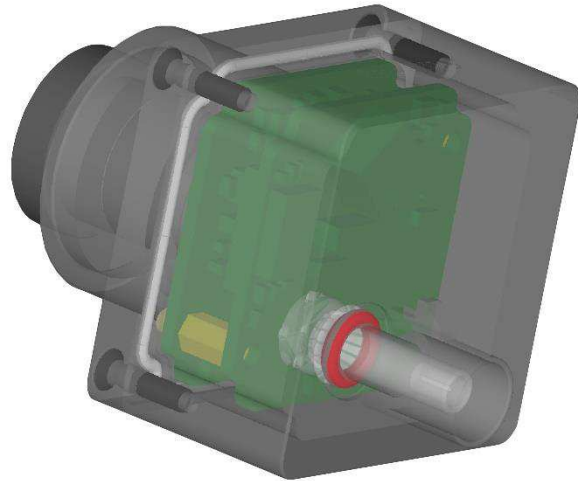

Cable Connector

- Housing Connector- FAKRA Z Type
- Cable length: 3 meters
Support single Coax Cable transmit up to 15 meters
- Cable Part#: FAK-SMZSMZ-0008
- FAKRA type connectors



Leopard Imaging Inc.



1130 Cadillac Ct., Milpitas, CA 95035, USA
Phone: +1-408-263-0988
Fax: +1-408-217-1960
Email: sales@leopardimaging.com
Website: www.leopardimaging.com

Ordering Information

Part#: LI-IMX224-GMSL2-xxxH

Note:

xxxH - 050H: FOV H 50°
 100H: FOV H 100°

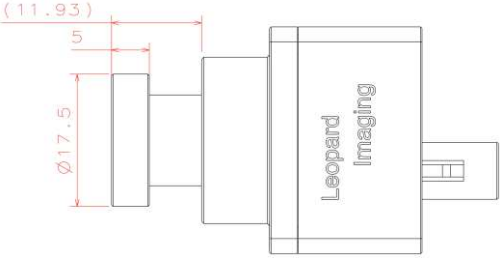
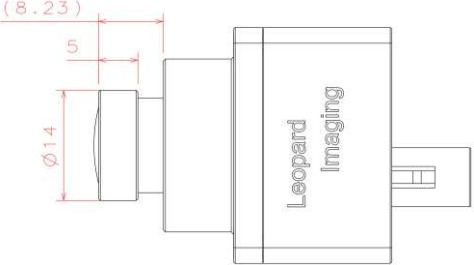
LI-IMX224-GMSL2-050H	LI-IMX224-GMSL2-100H
	
<p>Lens: M127B0618W Lens EFL: 6.0 mm FOV(D): 67° FOV(H): 52° FOV(V): 38.5°</p>	<p>Lens: M128B02820WM12R1 Lens EFL: 2.8 mm FOV(D): 130° FOV(H): 102° FOV(V): 76.5°</p>
	



Leopard Imaging Inc.

1130 Cadillac Ct., Milpitas, CA 95035, USA
 Phone: +1-408-263-0988
 Fax: +1-408-217-1960
 Email: sales@leopardimaging.com
 Website: www.leopardimaging.com

LI-USB30-IMX224-GMSL2-xxxH

LI-GMSL2-DESER

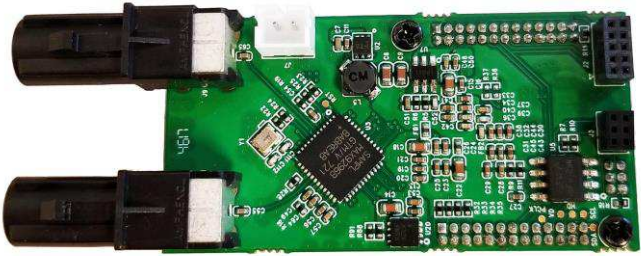

Front View

LI-USB30-CNTL

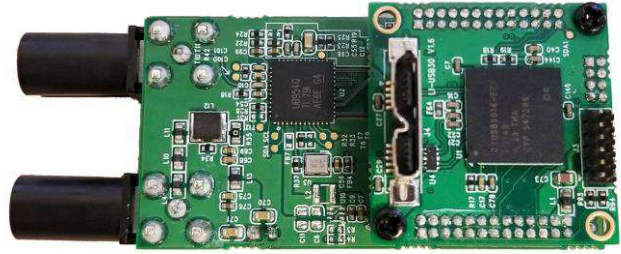

Back View

LI-IMX224-GMSL2-xxxH can connect to USB 3.0 EVA module as a USB 3.0 camera.
Part#: **LI-USB30-IMX224-GMSL2-xxxH**

Key Features

- USB 3.0 Super Speed support
- RAW data output without compression
- UVC compliance
- Provide customization services
- 12VDC Power Supply
- Weight: 86 g
- Single Coax Cable transmit up to 15 meter PoC(Power over Cable)
- Support 1317x977 @ 30fps
- Power consumption: TBD
- Support Windows, Linux OS and other OS which includes the UVC drivers

SDK Supported

- Camera Tool Source Code in C#
- Capture & Display
- Save file as BMP & RAW format
- Support register access function



Leopard Imaging Inc.

1130 Cadillac Ct., Milpitas, CA 95035, USA
Phone: +1-408-263-0988
Fax: +1-408-217-1960
Email: sales@leopardimaging.com
Website: www.leopardimaging.com

Revision History

Revision	Description	Release Date
1.0	First Release	11. Jan. 2018
1.1	Update the lens information	22. Jun. 2018

