

Remote I/O JC Series

HUB MODULE

(CUnet use)

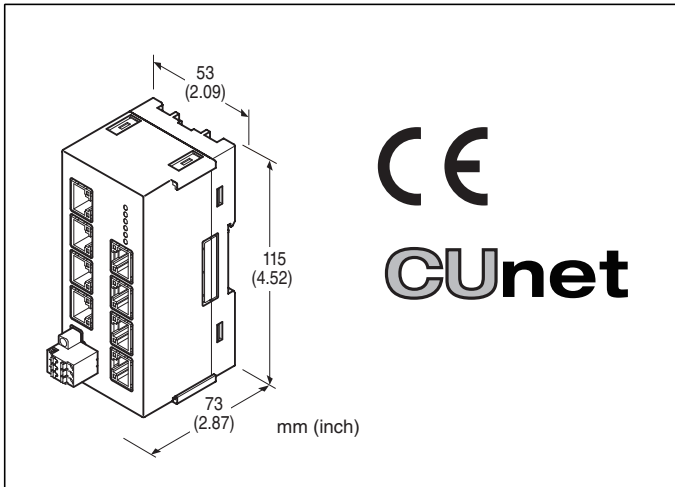

MODEL: JC-CU-[1]-1[2]-[3][4]

ORDERING INFORMATION

- Code number: JC-CU-[1]-1[2]-[3][4]
Specify a code from below for each of [1] through [4].
(e.g. JC-CU-7-12-R/Q)
- Specify the specification for option code /Q
(e.g. /SET)

[1] I/O TYPE

- 3: 3 port (trunk 1 port, feeder 2 port)
- 7: 7 port (trunk 1 port, feeder 6 port)

TERMINAL BLOCK

- 1: Tension clamp terminal block for power supply
RJ-45 Modular jack for communication

[2] COMMUNICATION CONNECTOR PIN ASSIGNMENT

- 1: 3, 4 pair wiring
- 2: 4, 5 pair wiring
(Ethernet LAN cable pin assignment)

[3] POWER INPUT

DC Power

- R: 24 V DC
(Operational voltage range 24 V \pm 10 %, ripple 10 %p-p max.)
- R5: 16 - 32 V DC
(Operational voltage range 15 - 33 V DC, ripple 10 %p-p max.)

[4] OPTIONS

Other Options

- blank: none
- /Q: Option other than the above (specify the specification)

SPECIFICATIONS OF OPTION: Q

EX-FACTORY SETTING

- /SET: Preset according to the Ordering Information Sheet
(No. ESU-9042)

FUNCTIONS & FEATURES

The HUB Module for CUnet (model: JC-CU) extends total length of network cable and branch cable of CUnet. Total max. length is 900 m when transfer rate is 3 Mbps. In order to connect the JC-CU, the unit configuring CUnet must support HUB module.

GENERAL SPECIFICATIONS

Number of port:

- JC-CU-3: Trunk 1 port, feeder 2 port
- JC-CU-7: Trunk 1 port, feeder 6 port
- Max. number of inserted HUBs: 2

(Depending on specification of CUnet I/O unit)

Connectable devices: The products conforming to CUnet Connection

- Network:** RJ-45 Modular Jack
- Power input:** Separable tension clamp terminal
- Power on LED:** PWR (green) turns on while the power is supplied.

CUnet COMMUNICATION

Communication mode: half-duplex

Network cable

- Shield cable
ZHY262PS (Shinko Seisen Industry Co., Ltd.)
ZHT262PS (Shinko Seisen Industry Co., Ltd.)
- Dual-shield cable
ZHY262PBA (Shinko Seisen Industry Co., Ltd.)

Transmission distance / Transfer rate:
Refer to the table below (Selectable with DIP switch. Factory default: 12 Mbps)

Terminating resistor:

- Trunk built-in (Selectable with DIP switch. Factory default: disable)
- Feeder built-in

Status indicator LEDs: ERR, LNK

(Refer to the instruction manual for details)

Transfer rate	Number of inserted HUBs		
	0	1	2
12Mbps	100m	200m	300m
6Mbps	200m	400m	800m
3Mbps	300m	600m	900m

INSTALLATION

Rated current for power supply connector: 8A

Power consumption:

JC-CU-3: Approx. 0.9 W

JC-CU-7: Approx. 1.2 W

Operating temperature: -10 to +55°C

Operating humidity: 10 to 90 %RH (non-condensing)

Atmosphere: No corrosive gas or heavy dust

Mounting: Surface or DIN rail

Weight

JC-CU-3: 150 g (0.33 lb)

JC-CU-7: 160 g (0.35 lb)

PERFORMANCE

Insulation resistance: $\geq 100 \text{ M}\Omega$ with 500 V DC

JC-CU-3 (CU0A or CU0B to CU1 or CU2 or FE to power)

JC-CU-7 (CU0A or CU0B to CU1 or CU2 or CU3 or CU4 or CU5 or CU6 or FE to power)

Dielectric strength: 1500 V AC @ 1 minute

JC-CU-3 (CU0A or CU0B to CU1 or CU2 or FE to power)

JC-CU-7 (CU0A or CU0B to CU1 or CU2 or CU3 or CU4 or CU5 or CU6 or FE to power)

STANDARDS & APPROVALS

Refer to the manuals to comply with the standards.

EU conformity:

EMC Directive

EMI EN 61000-6-4

EMS EN 61000-6-2

RoHS Directive

EXTERNAL VIEW

■ I/O TYPE : 3 3port
 • SIDE VIEW

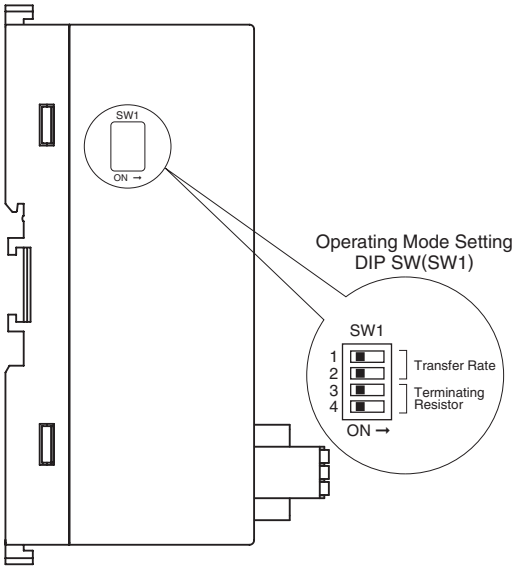

• FRONT VIEW

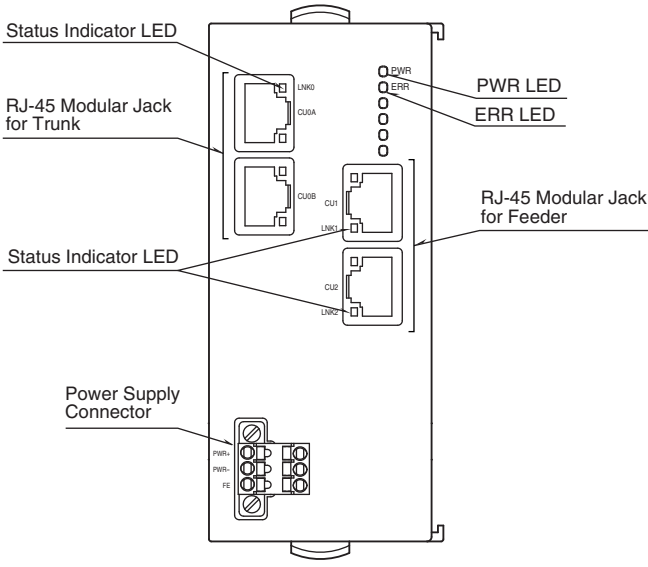

■ I/O TYPE : 7 7port
 • SIDE VIEW

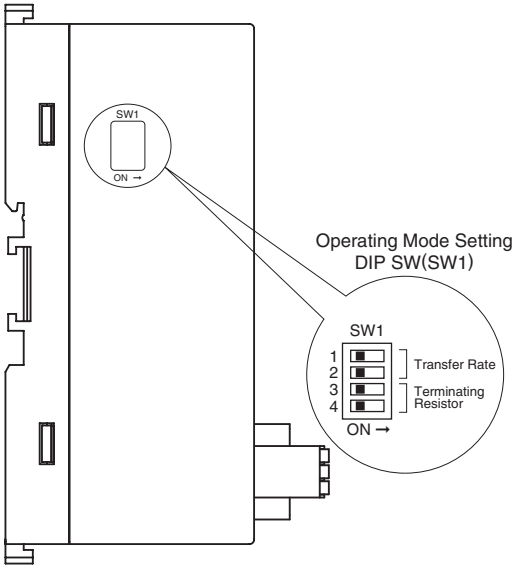

• FRONT VIEW

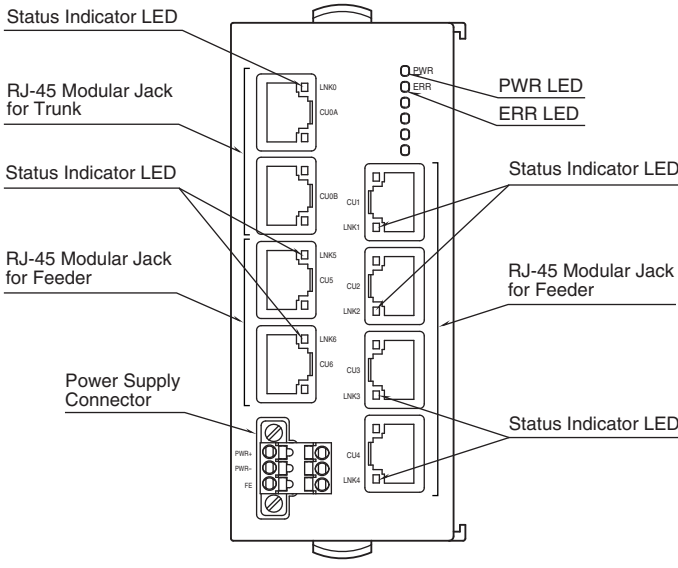

CONNECTION DIAGRAMS

■ POWER SUPPLY

Cable connector: TFMC1,5 / 5-STF-3,5
(Phoenix Contact) (included in the package)

Applicable wire size: 0.2 – 1.5 mm²; stripped length 10 mm

Recommended solderless terminal

- AI0,25-10YE 0.25 mm² (Phoenix Contact)
- AI0,34-10TQ 0.34 mm² (Phoenix Contact)
- AI0,5-10WH 0.5 mm² (Phoenix Contact)
- AI0,75-10GY 0.75 mm² (Phoenix Contact)
- A1-10 1.0 mm² (Phoenix Contact)
- A1,5-10 1.5 mm² (Phoenix Contact)

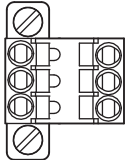

- | | | |
|---|----------|------------------|
| 1 | 1. PWR + | Power Supply |
| 2 | 2. PWR - | Power Supply |
| 3 | 3. FE | Functional earth |

■ NETWORK

Recommended cable connector: TM21P-88P (Hirose Electric)
(not included in the package)

• COMMUNICATION CONNECTOR PIN ASSIGNMENT CODE: 1

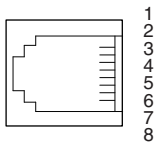

Trunk (CU0A, CU0B)

- | | |
|--------|-------------|
| 1. NC | Unused |
| 2. NC | Unused |
| 3. TR+ | Network (+) |
| 4. TR- | Network (-) |
| 5. NC | Unused |
| 6. NC | Unused |
| 7. NC | Unused |
| 8. SLD | Shield |

Feeder (CU1, CU2, CU3, CU4, CU5, CU6)

- | | |
|--------|-------------|
| 1. NC | Unused |
| 2. NC | Unused |
| 3. TR+ | Network (+) |
| 4. TR- | Network (-) |
| 5. NC | Unused |
| 6. NC | Unused |
| 7. NC | Unused |
| 8. SLD | Shield |

• COMMUNICATION CONNECTOR PIN ASSIGNMENT CODE: 2

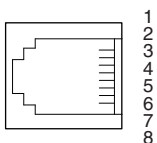

Trunk (CU0A, CU0B)

- | | |
|--------|-------------|
| 1. NC | Unused |
| 2. NC | Unused |
| 3. NC | Unused |
| 4. TR- | Network (-) |
| 5. TR+ | Network (+) |
| 6. NC | Unused |
| 7. NC | Unused |
| 8. SLD | Shield |

Feeder (CU1, CU2, CU3, CU4, CU5, CU6)

- | | |
|--------|-------------|
| 1. NC | Unused |
| 2. NC | Unused |
| 3. NC | Unused |
| 4. TR- | Network (-) |
| 5. TR+ | Network (+) |
| 6. NC | Unused |
| 7. NC | Unused |
| 8. SLD | Shield |

CONNECTION WITH OTHERS

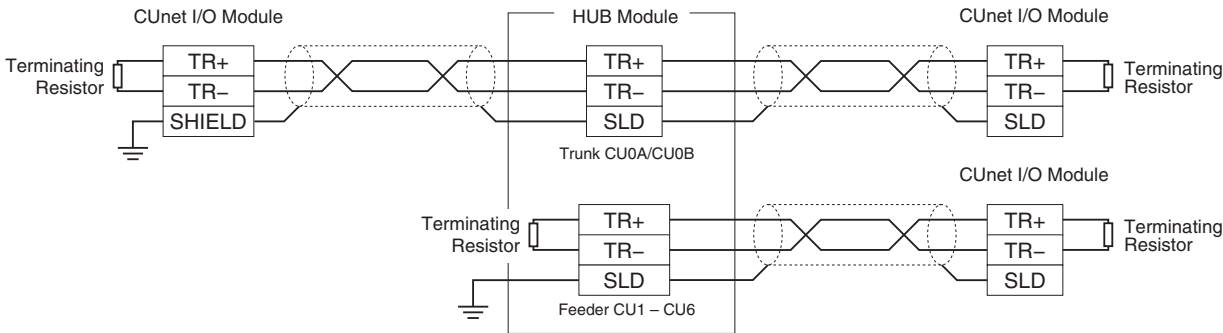

Note: Be sure to turn ON the switch of the terminating resistor located at both ends of the modules.

DIMENSIONS unit: mm (inch)

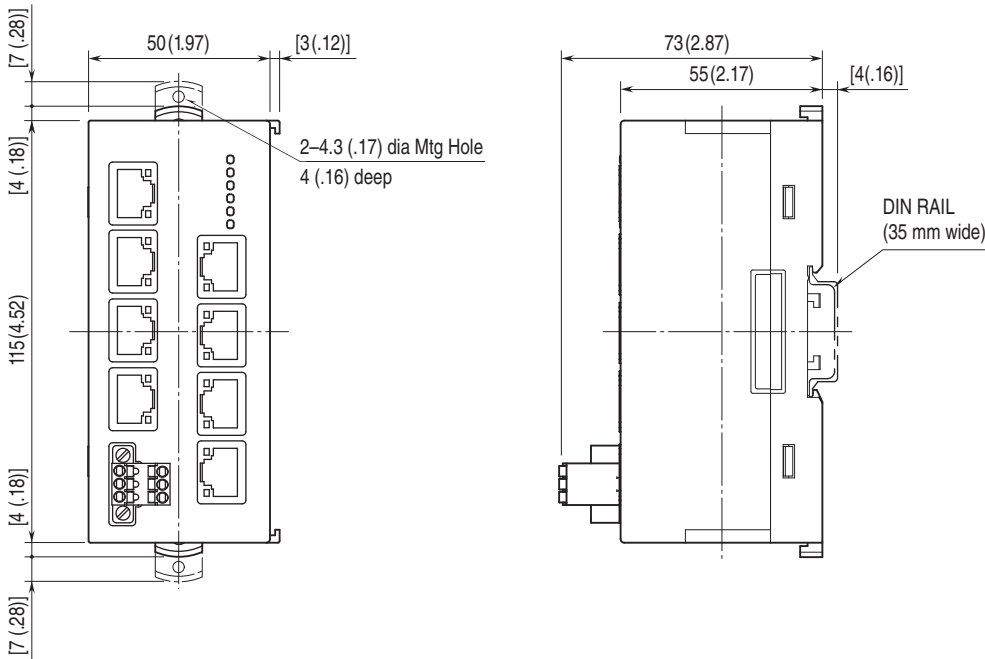

MOUNTING REQUIREMENTS unit: mm [inch]

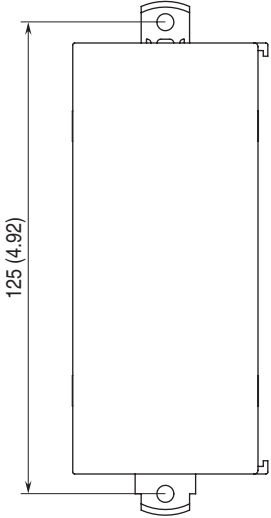

SCHEMATIC CIRCUITRY

Note: In order to improve EMC performance, bond the FE terminal to ground.

Caution: FE terminal is NOT a protective conductor terminal.

■ JC-CU-3-11

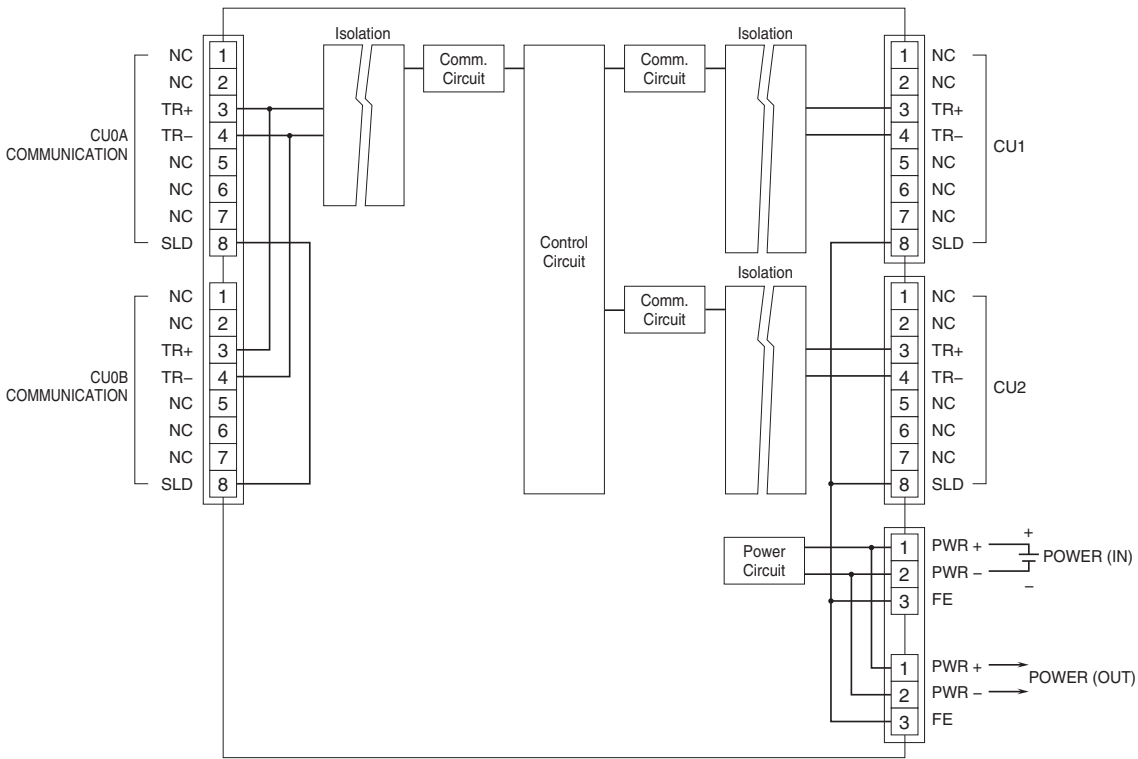

■ JC-CU-7-11

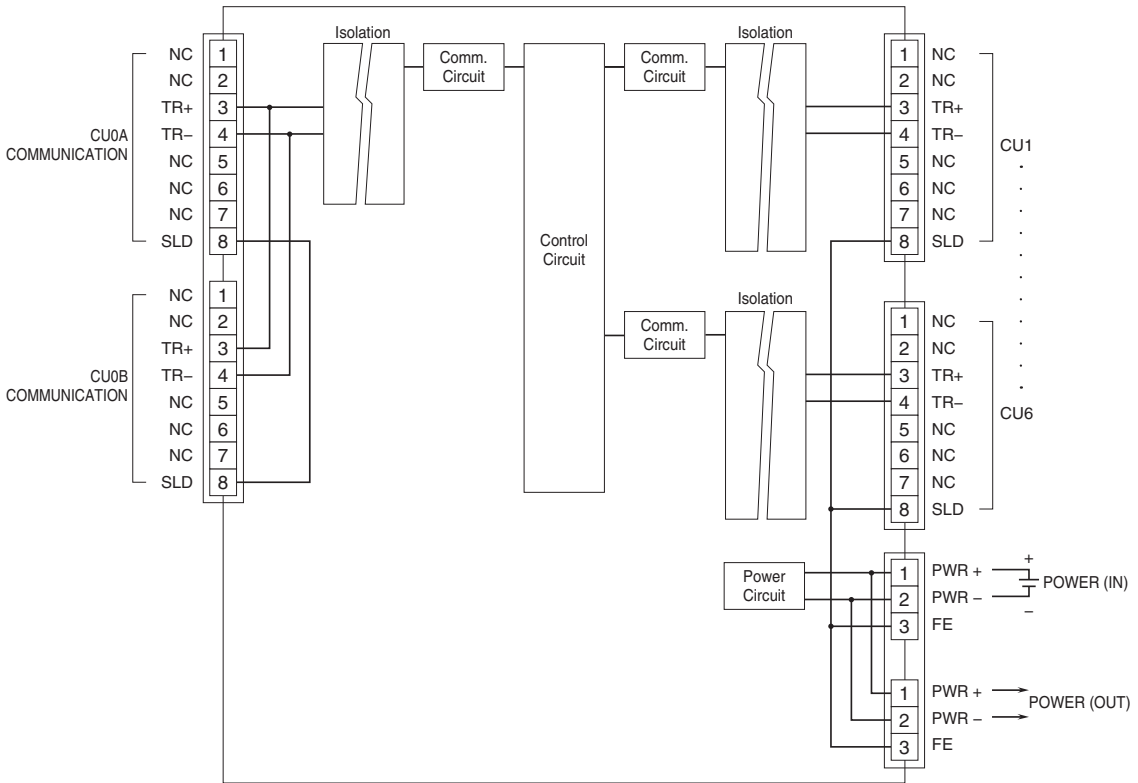

■ JC-CU-3-12

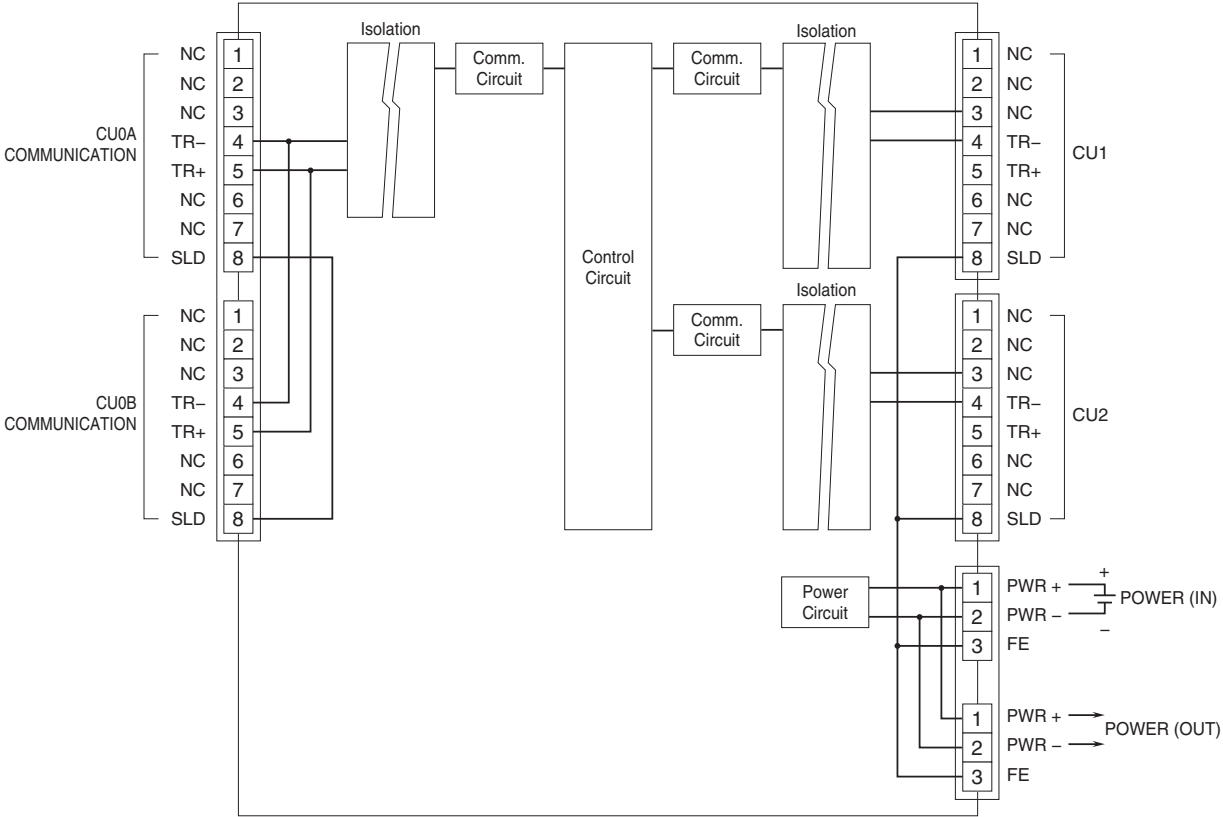

■ JC-CU-7-12

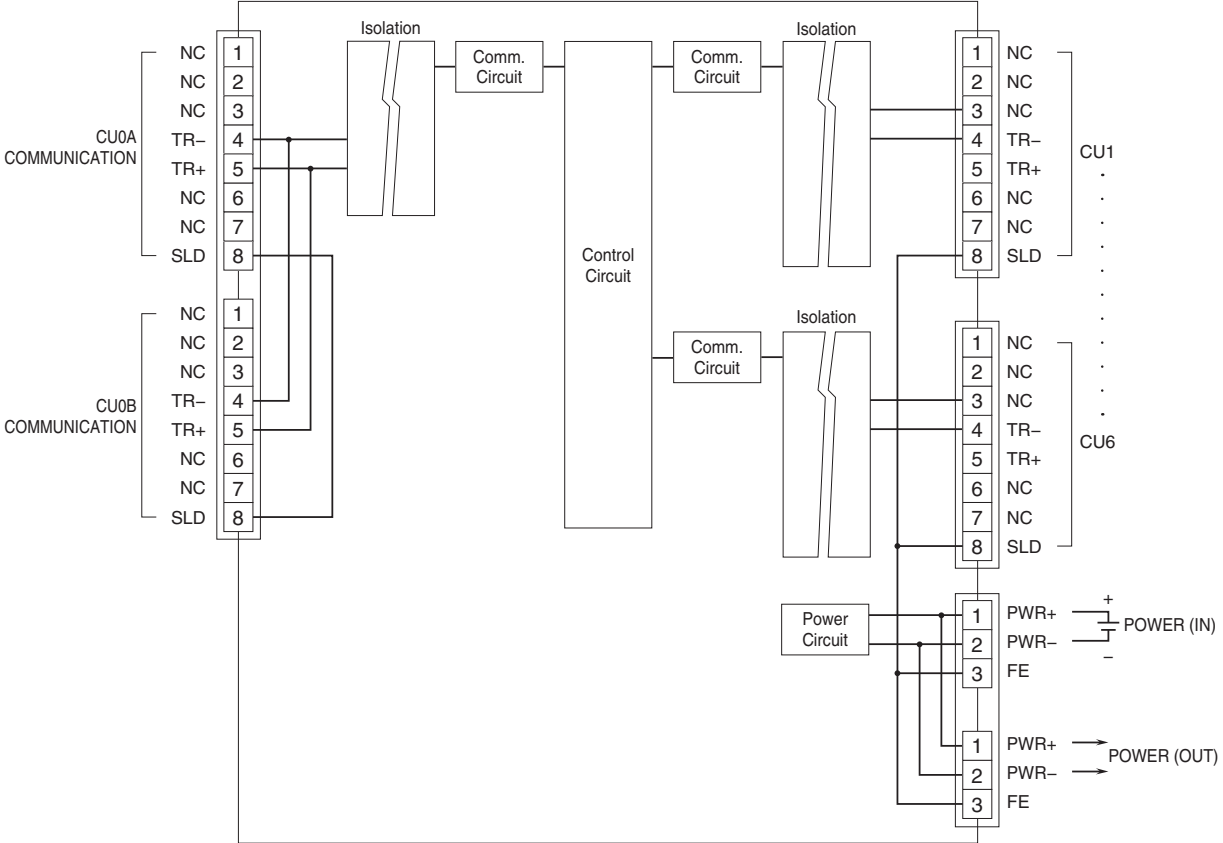

SYSTEM CONFIGURATION EXAMPLES

System configuration example of Number of inserted HUBs: 2 is shown below.

The number of inserted HUBs is determined by the route, where max. number of HUB is gone through, out of all route.

When HUB module is used, the frame option must be set in any CUnet I/O module connected to the network. Refer to the instruction manual of your CUnet I/O module for the detailed settings.

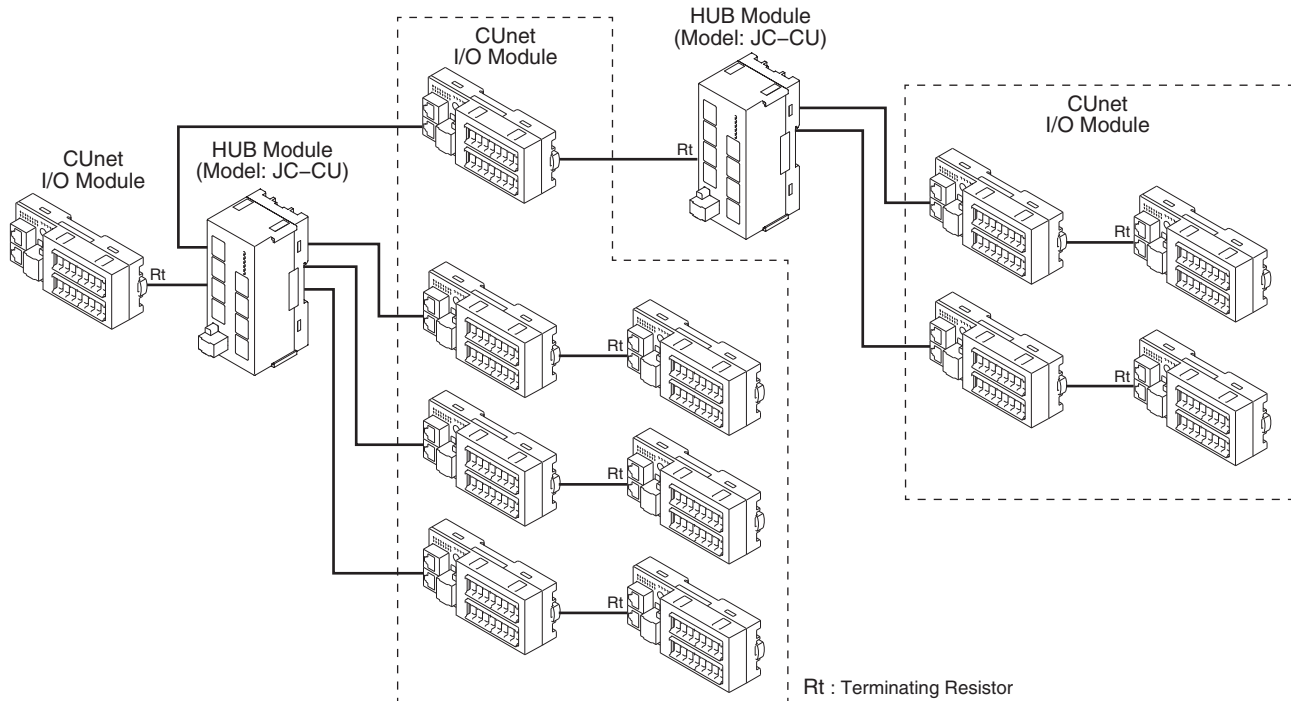

Note 1) Max. transmission distance between CUnet I/O module and HUB module, HUB module and HUB module is as follows.
100 m at 12 Mbps, 200 m at 6 Mbps and 300 m at 3 Mbps.

Note 2) Be sure to connect CU0A/CU0B to the host side.

Note 3) The terminating resistor must be enabled for the modules at both end of the communication line. The terminating resistor is incorporated in the feeder side port of the HUB module.



Specifications are subject to change without notice.