

MS-332-7

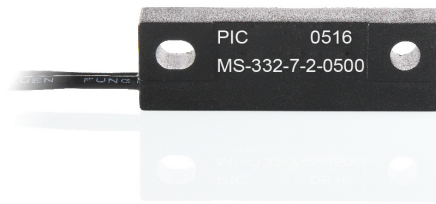

MS-332-7

Normally Closed Reed Sensor

Electrical Characteristics @ 25 °C

Contact form		B
Contact rating max.	W / VA	5
Switching voltage max.	VDC	175
	VAC	120
Switching current max.	A	0.25
Carry current max.	A	1.5
Breakdown voltage min.	VDC	200
Total resistance max. (initial)	mΩ	200
Insulation resistance min.	Ω	10 ⁹

Features

- No power supply required
- Customized types available
- Various sensitivity ranges available
- Non pole oriented actuation

Magnetical Characteristics (of unmodified Reed Switch) @ 25 °C

Pull in range available	AT	15 - 30
Drop out min.	AT	5
Test coil	TC	200
Test equipment tolerance	± AT	2

Operating Characteristics (of unmodified Reed Switch) @ 25 °C

Switching frequency max.	Hz	100
Resonant frequency typ.	Hz	1100
Operate time max. (incl. bounce)	ms	0.7
Release time max.	ms	1

Environmental Characteristics

Operating temperature	°C	-20 to +85
Vibration (50-2000 Hz)	g	30
Shock (1/2 sin 11 ms)	g	50

Approvals

RoHS

REACH

Dimensions in mm

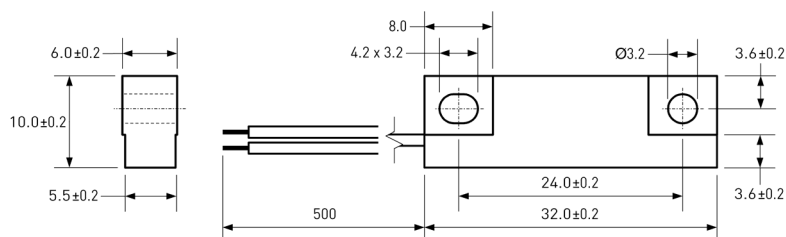

Ordering Information

Packing Unit	50 pcs
Weight per piece	5.8 g
Weight per package	300 g
Standard AT Ranges	
	2 = 15 to 20 AT
	3 = 20 to 25 AT
	4 = 25 to 30 AT

Ordering Example

MS-332-7-2 describes MS-332-7 with 15 to 20 AT.

MS-332-7

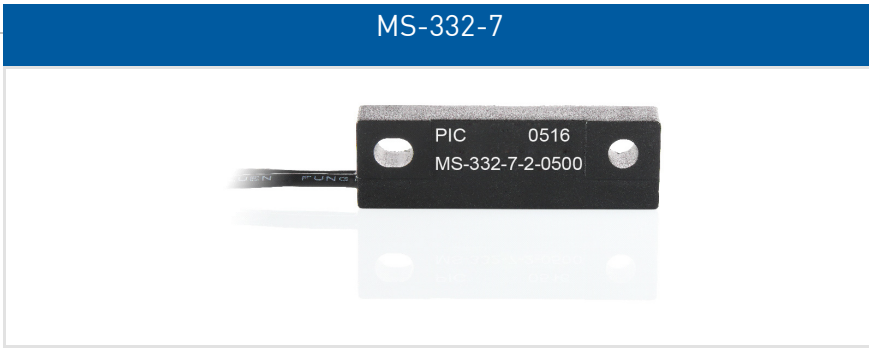

MS-332-7

Normally Closed Reed Sensor

Material Information		
	Material	Colour
Housing	ABS	black
Cable	UL 1007/1569, AWG 24, 4 mm stripped and tinned	black
Potting compound	Epoxy	black

Test Procedure of final Reed Sensor

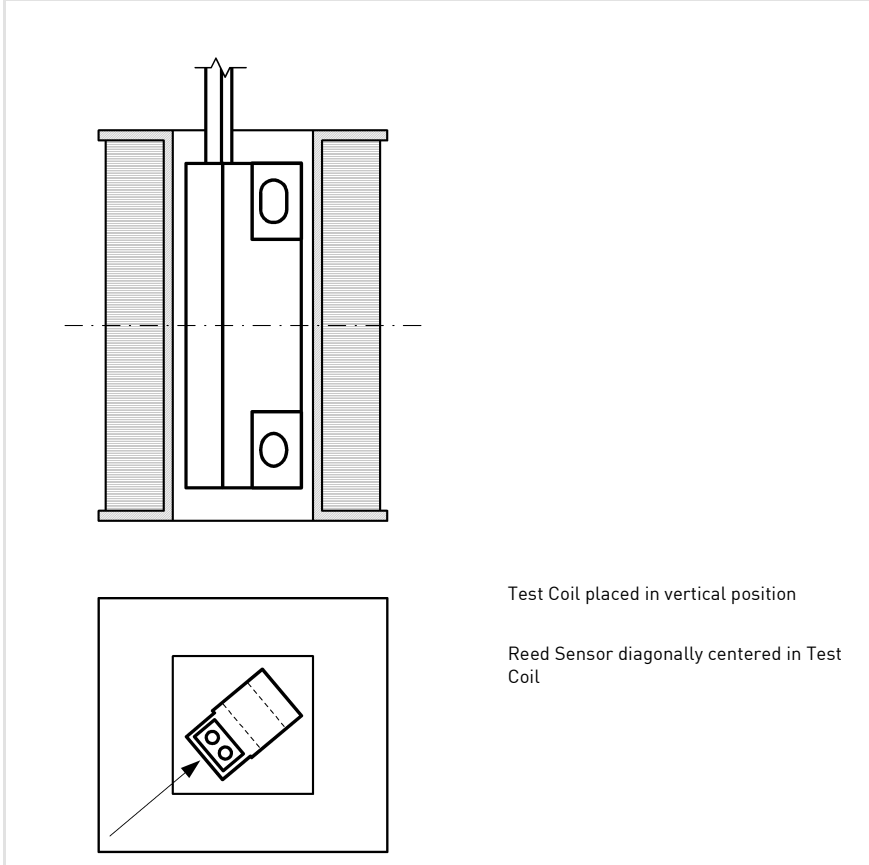

Test Coil placed in vertical position

Reed Sensor diagonally centered in Test Coil

Test Parameters

Test coil	TC- 324
Test programs	
AT range	Test program
2 =	MS-332-7-2
3 =	MS-332-7-3
4 =	MS-332-7-4

Remarks

When mounted onto ferromagnetic parts switching distance of MS-332-7 may reduce.
Electromagnetical influences and magnetic fields may change the switching behaviour of the sensor.

Only non-ferromagnetic screws to be used for mounting.

Matching actuator MSM-332 available as well.

Product image serves as example only.