**Guidelines to improve conducted noise robustness on STM32F0,
STM32F3 and STM32L0 series touch sensing applications**

Introduction

Immunity of touch sensing systems to conducted RF voltage is required at different level depending on applications (home appliances, automotive, health care, ...). Moreover, touch sensing systems are often designed with the requirement to meet industry standards, especially in the EMC compliance domain.

It is important to understand the environment in which the touch application will be used, and apply adapted techniques to address the effects of unwanted noise disturbances.

This application note provides basic overview of conducted immunity testing and some guidelines to keep the system reliable when it is exposed to conducted noise.

Note: STMicroelectronics is providing free STMTouch touch sensing firmware libraries which are available either as standalone packages (STM8L-TOUCH-LIB) or directly integrated into the corresponding STM32Cube package (STM32CubeL0, STM32CubeF0, ...).

Table 1. Applicable products

Type	Applicable products
Microcontrollers	STM32F0 series, STM32F3 series, STM32L0 series.

Contents

- 1 Conducted noise immunity 5**
 - 1.1 Signal to Noise ratio (SNR) 5
 - 1.2 IEC61000-4-6 standard 5
 - 1.2.1 Test setup 5
 - 1.2.2 Injected signal characteristics 6
 - 1.2.3 Noise immunity evaluation 7
 - 1.2.4 IEC61000-4-6 standard limitation 7

- 2 Surface charge transfer acquisition principle overview 8**

- 3 Test set up proposal to detect worst case 9**
 - 3.1 Test setup 9
 - 3.2 Generator settings 10
 - 3.3 Data logging and data processing 10

- 4 How to improve noise immunity 12**
 - 4.1 Proposed improvement techniques 12
 - 4.2 Active Shield 13
 - 4.3 Spread Spectrum 15
 - 4.4 Threshold adjustment 16
 - 4.5 SW filter (debounce) 16

- 5 STM32303C-EVAL board example 17**
 - 5.1 Firmware 17
 - 5.2 Performance 17
 - 5.3 Conducted noise evaluation 17

- 6 Conclusion 18**

- 7 Revision history 19**

List of tables

Table 1.	Applicable products	1
Table 2.	Test levels	7
Table 3.	User configuration settings related to immunity improvements	17
Table 4.	Document revision history	19

List of figures

Figure 1.	Standard IEC61000-4-6 test setup	5
Figure 2.	Injected signal	6
Figure 3.	Charge transfer equivalent capacitance model	8
Figure 4.	Test condition	9
Figure 5.	Data processing	11
Figure 6.	Active Shield	13
Figure 7.	Electrode and Active Shield Waveforms	14
Figure 8.	Waveform detail	15

1 Conducted noise immunity

1.1 Signal to Noise ratio (SNR)

Signal to noise ratio (SNR) is an important characteristic in the evaluation of a touch sensing system.

SNR measurement results are only valid for a specified board and for the noise environment at the moment of the measure. This is why the noise immunity is better evaluated by referring to a standard like IEC61000-4-6 where the noise level and the test conditions are specified.

1.2 IEC61000-4-6 standard

The IEC61000-4-6 standard specifies the test procedure to evaluate the noise immunity of an EUT (equipment under test).

1.2.1 Test setup

The test consists in using a noise generator to inject modulated noise signals into the EUT power supply lines as shown in [Figure 1](#).

Figure 1. Standard IEC61000-4-6 test setup

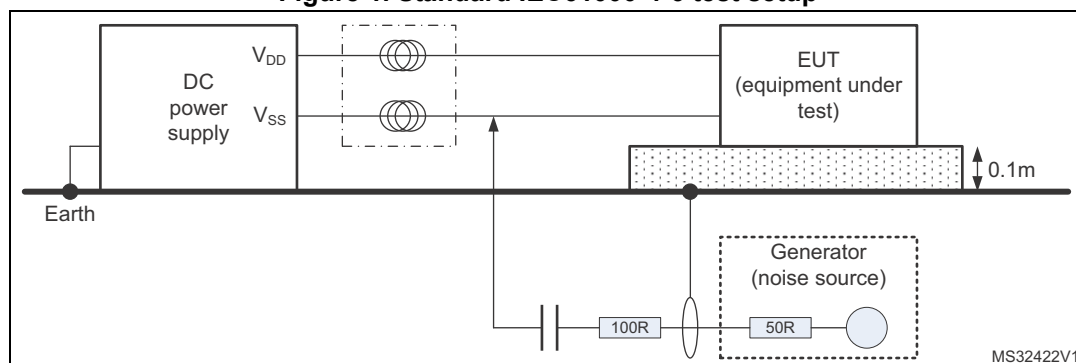

Touch sensing systems are based on capacitor variation measurements. The system must be able to detect capacitive variations as low as few picofarads on the sensor electrodes. Therefore such systems may be sensitive to conducted noise.

In a real touch sensing system, the main source of perturbation is introduced by the finger of the user. This is because the user is in the electric path between the system and the earth. In the test setup shown in [Figure 1](#), the injected signal simulates the noise perturbations to which a system may be exposed. By varying the frequency and the level of the injected signal, the test setup allows to characterize the situations where the touch system becomes unreliable.

1.2.2 Injected signal characteristics

The injected signal is a swept modulated noise source with a sine wave envelope as shown in [Figure 2](#):

- The noise generator frequency range is swept from 150 kHz to 80 MHz. The frequency is swept incrementally, the step size shall not exceed 1 % of the preceding frequency value.
- The signal is 80 % amplitude modulated with a 1 kHz sine wave.

Figure 2. Injected signal

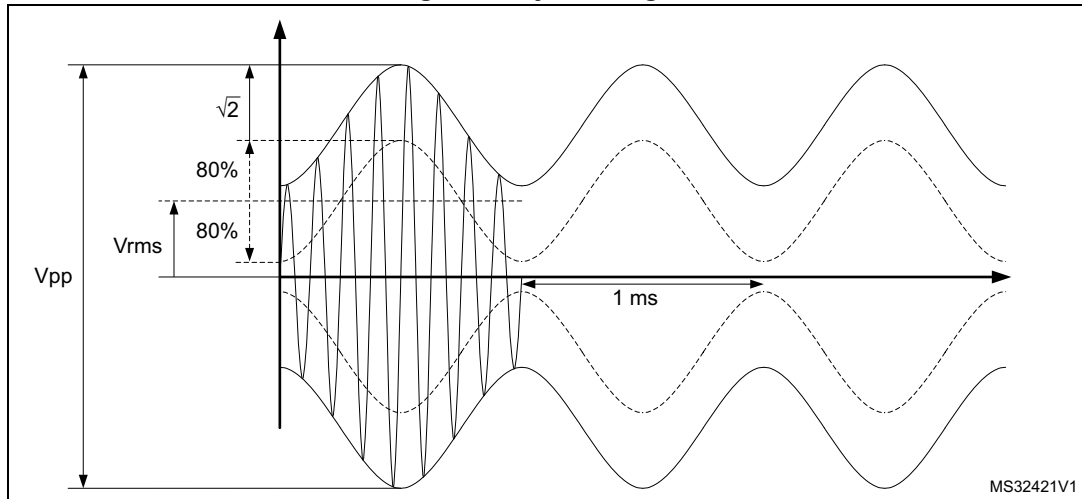

The modulated noise signal amplitude may be expressed either in V_{rms} or V_{pp} . Here is the formula to convert values from V_{rms} to V_{pp} :

$$V_{pp} \text{ value} = V_{rms} \times \sqrt{2} \times 1.8 \times 2$$

1.2.3 Noise immunity evaluation

The EUT noise immunity is evaluated by testing the ability of the EUT to behave according to the definition of a given Class when it is submitted to a given noise level. The [Table 2](#) below summarizes the different noise levels and Classes.

Table 2. Test levels

Standard class \ noise level	Level 1 1 Vrms	Level 2 3 Vrms	Level 3 10 Vrms
Class A: system work normally	Pass/fail	Pass/fail	Pass/fail
Class B: Some degradation in operation may occur (false touch detection or touch masking), but the product recovers once the stress is removed without any operator intervention	Pass/fail	Pass/fail	Pass/fail
Class C: same as class B but need external action (such as reset or power off/on) to return to normal state	Pass/fail	Pass/fail	Pass/fail
Class D: system that losses function or degradation of performance which is not recoverable	Pass/fail	Pass/fail	Pass/fail

1.2.4 IEC61000-4-6 standard limitation

As mentioned above, the minimum frequency step recommended by the standard to sweep the injected signal from 150 kHz to 80 MHz is 1 % of the preceding frequency value. At 500 kHz this represents a 5 kHz step. On most touch sensing systems, these steps are too large to be able to isolate the worst case situations. Some applications with narrow critical wave band can pass 3Vrms if the critical frequency falls just in the middle between tested frequencies, whereas the same application does not pass 1 Vrms if you set the test exactly on the critical frequency.

This is why it is important to set smaller steps around the critical frequencies. Sometime the standard bench is not able to do the appropriate step (for example 100Hz). [Section 3](#) proposes a method to detect the worst case.

2 Surface charge transfer acquisition principle overview

STM32F0, STM32F3 and STM32L0 series use a surface charge transfer acquisition principle. This principle is briefly described below.

The surface charge transfer acquisition principle consists in charging a sensor capacitance (C_x) and transferring a part of the accumulated charge into a sampling capacitor (C_s). This sequence is repeated until the voltage across C_s reaches a given threshold (V_{IH} in our case). The number of charge transfers required to reach the threshold is a direct representation of the size of the electrode capacitance.

When the sensor is touched, the sensor capacitance to the earth is increased so the C_s voltage reaches the threshold with less count and the measurement value decreases. When the measurement value falls below a defined threshold, a detection is reported.

Noise injection disturbs the measurement proportionally to its amplitude and depending on its frequency. Worst case is generally found at a noise frequency close to the charge transfer frequency (assuming no techniques are used to spread this frequency).

Figure 3. Charge transfer equivalent capacitance model

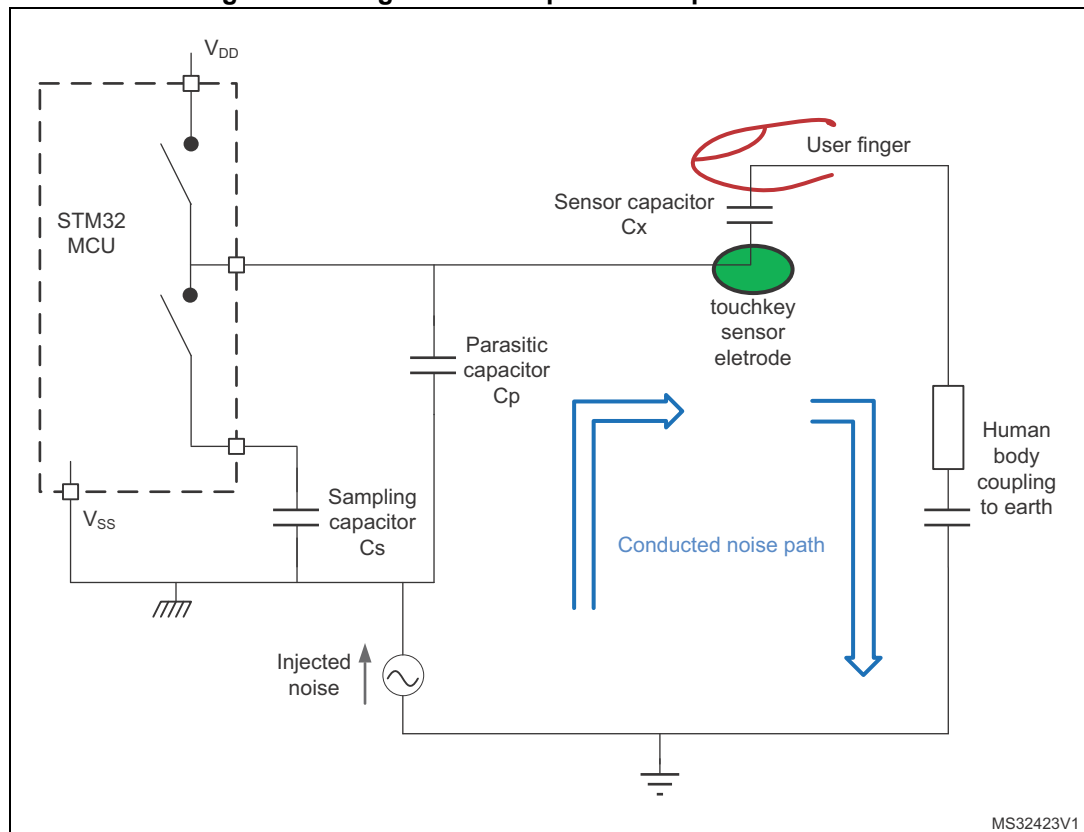

3 Test set up proposal to detect worst case

Most of the IEC61000-4-6 compliant generators do not offer the ability to generate a step smaller than 1 kHz. As previously indicated, to determine the most critical noise frequency, it is generally required to use 100 Hz steps or even 10 Hz steps. The following setup is an alternative to find out the most critical noise frequencies and to evaluate the robustness of the EUT at these frequencies.

Note: The noise frequencies impacting the equipment are generally around the charge transfer frequency and up to 40MHz. Higher noise frequency does not have an impact on the equipment operation.

3.1 Test setup

In order to simulate a human finger, a copper coin (from 10 to 16 mm diameter) with a 500 Ω serial resistor connected to GND can be used.

The CDN adaptor is the same as the one used in IEC61000-4-6.

Figure 4. Test condition

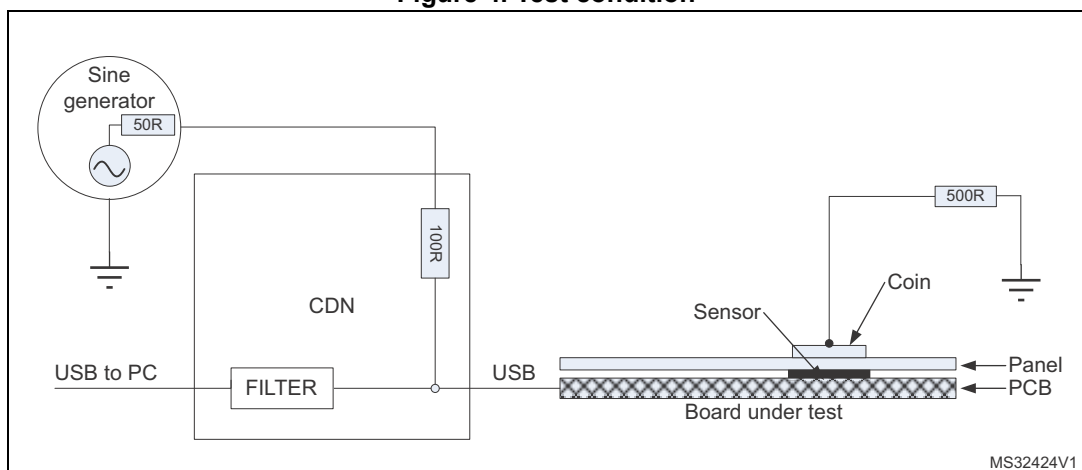

3.2 Generator settings

1. Select “sine wave” and “sweep” mode.
2. Sweep menu: time = 300 sec, return time = 0, linear, interval = 1 ms
3. Set Vpp value on the generator to obtain the corresponding voltage injected on the EUT in case of standard test.

Example: to test in the same condition as the standard at 3 Vrms, you must adjust the generator voltage to inject 15 Vpp measured on the board with oscilloscope.

Note: On AFG3102 TEKTRONIX generator, the modulation is not available in sweep mode.

4. Set the start and end frequencies such that the sweep range does not exceed 60 kHz for a 300 seconds duration. This recommendation allows to detect worst case level with sufficient accuracy (typically less than 5 % error).

Note: An external amplifier might be needed in case the generator would not be able to reach the appropriate injection level.

3.3 Data logging and data processing

Data logging

The STMStudio^(a) tool log function can be used to collect data from variable.

Example: “MyChannels_Data[x].Delta” and “MyTKeys[(x)].p_Data->Stateld”

Data processing

A graphical tool is recommended for analysis of the results. For example with Microsoft[®] Excel[®] 2D you can obtain the chart shown in [Figure 5](#).

In this example frequency sweep starts at 500 kHz and ends at 550 kHz. Noise level is set on the generator to 4.6 Vpp (no modulation). Detect out threshold is set to 50, the sensor is touched and the detection is valid if measured delta is upper 50 else the touch detection is lost (error is reported). It means that 4.6 Vpp is the limit to avoid detection loss (4.5 Vpp pass)

As a comparison, IEC61000-4-6 standard recommendation to use 1 % frequency steps would have led to explore only ten frequencies in this range, so the chances to detect worst case would have been very low!

a. STMStudio: order code STM6STUDIO

Figure 5. Data processing

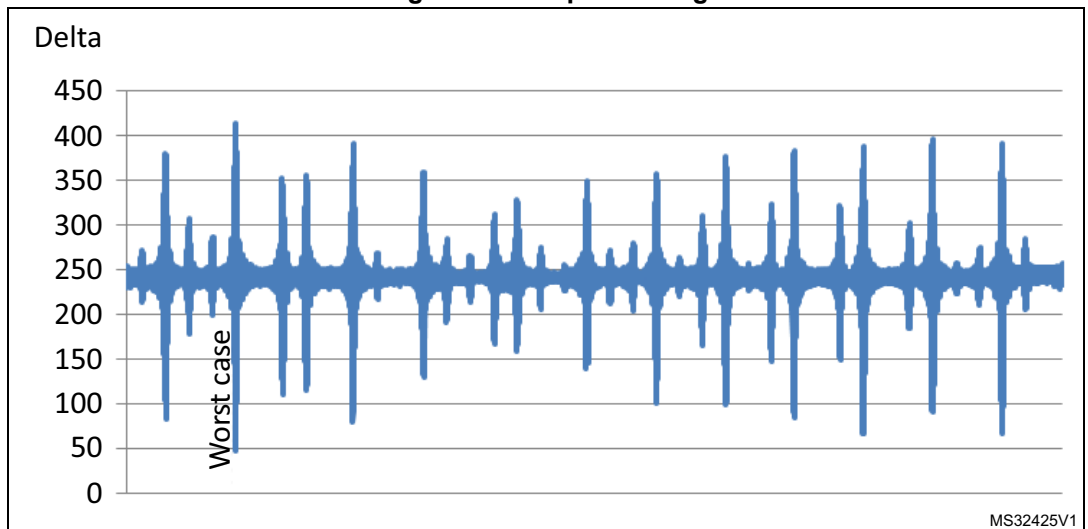

4 How to improve noise immunity

Two directions can be followed to improve noise immunity:

- decrease noise level
- increase signal (measurement sensitivity).

Note: In order to obtain a real benefit on the SNR, the noise reduction should not degrade the sensitivity and vice versa.

4.1 Proposed improvement techniques

Several improvement techniques are introduced below:

- **Active Shield:**
This feature increases measurement sensitivity.
- **Spread Spectrum:**
When activated, Spread Spectrum creates several acquisition frequencies. This feature is particularly appropriate for reducing overall noise level inside the measurement when the noise is concentrated on certain frequencies (as opposed to a white noise).
- **Detection thresholds:**
Adjusting these parameters allows to optimize the reported detection witch is a compromise between false detection and detection loss.
- **SW filter:**
SW filter such as debounce filter can be used to remove short and unwanted detections.
- **Frequency hopping:**
Upon detection of excessive noise on a dedicated channel, the firmware is able to change the acquisition frequency in order to move out of the disturbed frequency range. There may be some situations where frequency hopping and Spread Spectrum cannot be activated both at the same time. This is useful to get a Class B operation with no false touch detections which is generally preferable than having some false touch detections.
- **Channel blocking:**
It consists in using an additional channel to detect noise and cancel touchkey detection if noise reach a determined threshold.
- **Impedance path to earth:**
Decreasing the impedance path to earth is also a good way to cancel the conducted noise effect (use of a metallic chassis, system ground and earth connected together, ...). For instance, an application offering a direct connection between the earth and the system ground is not impacted by the conducted noise.

Note: Such an approach does not improve the system performances when performing the conducted noise test according to the IEC61000-4-6 standard.

4.2 Active Shield

The Active Shield is an electrode which wraps around the sensor. The goal is to minimize the parasitic capacitance between the sensor and the ground. To drive the shield electrode, a channel of a dedicated group with its own C_s can be used.

Figure 6. Active Shield

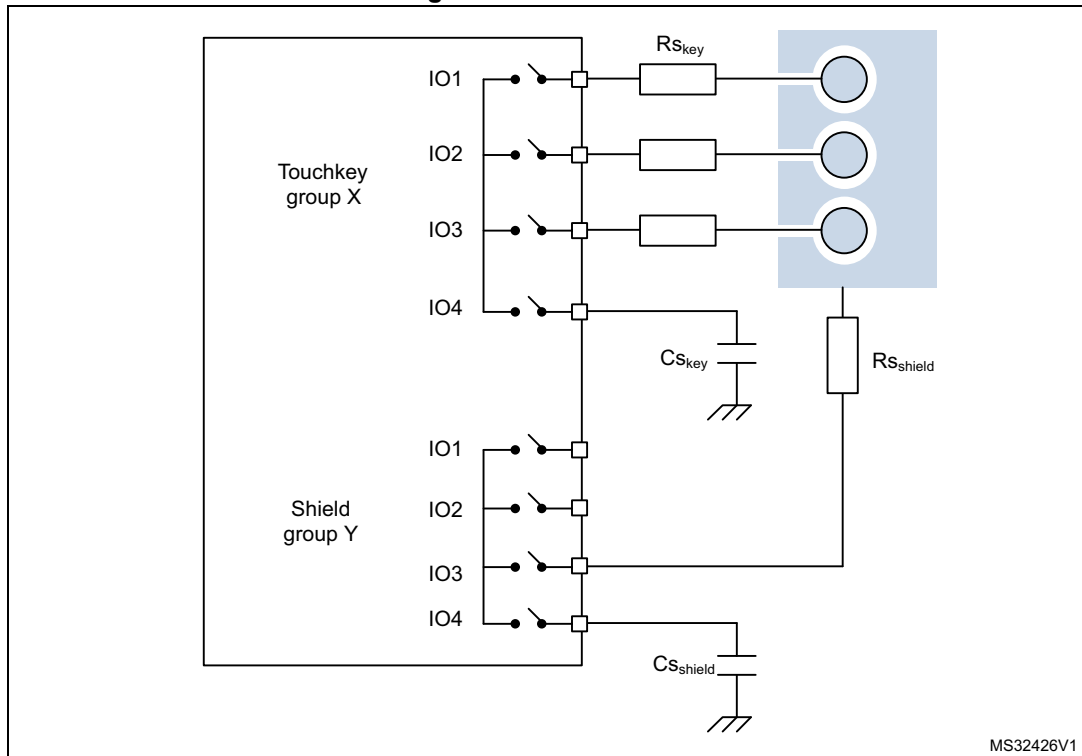

It is important to check the shield electrode waveform. C_s shield capacitance value and R_s shield serial resistor value must be adjusted in order to obtain the same signal shape as sensor electrode waveform (same amplitude, same response time).

[Figure 7](#) below shows the electrode sensor waveform in green and shield electrode waveform in yellow. C_s shield is adjusted to obtain approximately the same charge level at the end of the acquisition.

Figure 7. Electrode and Active Shield Waveforms

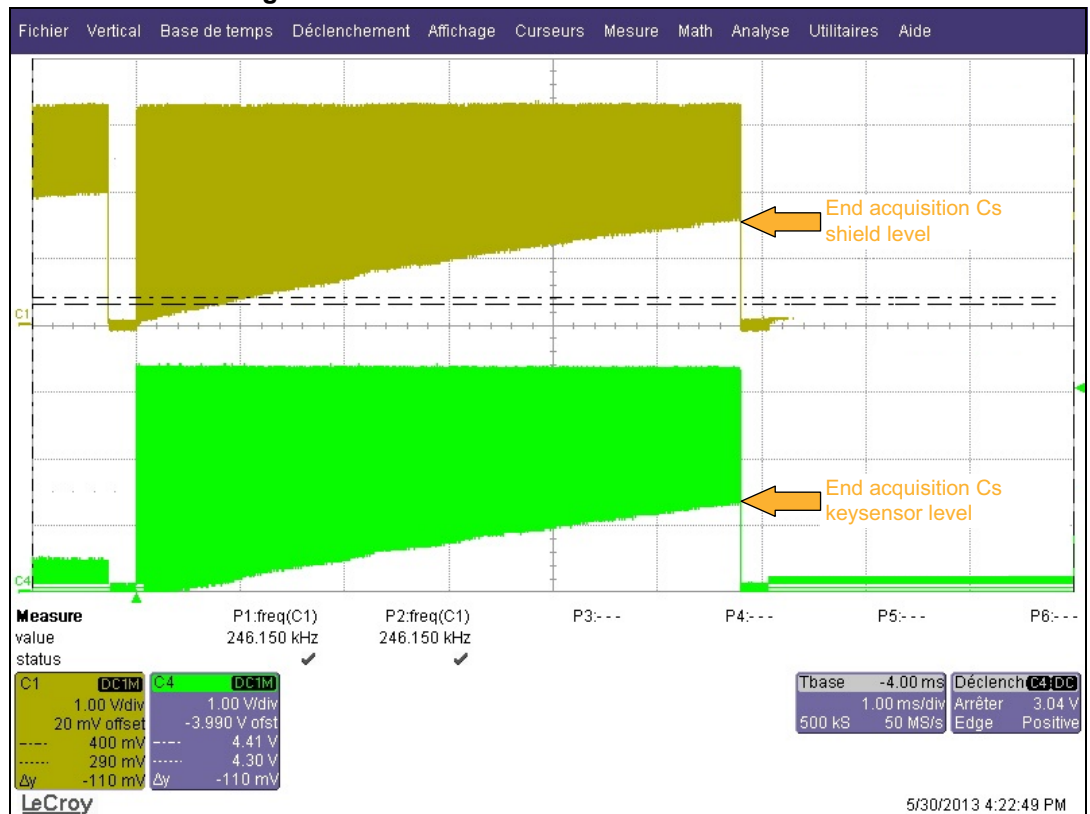
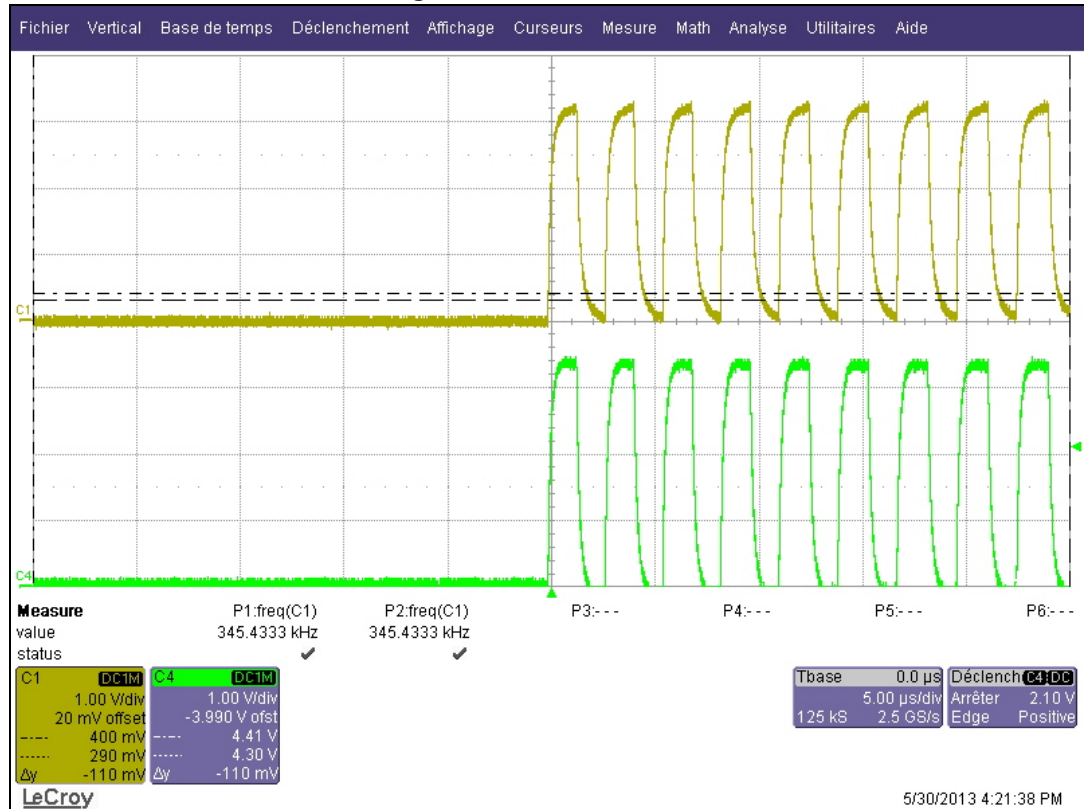

Figure 8 below is a zoom of Figure 7 at the beginning of acquisition: Rs and Cs shields are adjusted to obtain approximately the same rise and fall time on the shield electrode as sensor electrode waveform.

Figure 8. Waveform detail



When Active Shield is properly implemented the count value is about twice as much as the count value without Active Shield. Since the noise level is not increased, the SNR is improved by a factor of 2 and noise immunity as well.

The negative impact of this feature is the requirement to dedicate two more IOs and one more touch sensing group.

4.3 Spread Spectrum

Without Spread Spectrum the main noise susceptibility is found at the acquisition frequency and its value is 1/TCD (TCD = transfer cycle duration):

The main frequency (HCLK) in our STM32 comes from PLL output. Preferably we use the highest frequency recommended by specification (for STM32F0 series it is 48 MHz) to offer an optimum response time.

This frequency is divided in the TSC cell by programmable prescaler (PGCLK). This frequency determines the basic timing units for CTPH, CTPL:

$$\text{Transfer cycle duration} = (1 / (\text{PGCLK} \times ((\text{CTPH} + 1) + (\text{CTPL} + 1)))) + (\text{dead time} = 2 \times 1 / (\text{HCLK}))$$

By enabling the Spread Spectrum feature (TSLPRM_TSC_USE_SS to 1), the noise susceptibility is distributed on multiple frequencies.

This is done by adding HCLK timing units (period) to CTPH.

TSLPRM_TSC_SSD allows to set the number of distributed frequencies:

$$0 = 1 \times t_{SSCLK} \text{ to } 127 = 128 \times t_{SSCLK}$$

It is recommended to set TSLPRM_TSC_SSD to 127. In this case the number of distributed frequencies is $2^7 = 128$. The results is a noise immunity improved by approximately a factor of 7.

The negative impact of this feature is the degradation of the acquisition speed and thus the response time.

TSLPRM_TSC_SSD set to 127 adds an average of $64 \times (1/48 \text{ MHz}) = 1.33 \mu\text{s}$ to each count. For a 2000 counts acquisition duration, 2.6 ms will be added due to Spread Spectrum activation.

Usually end users need a response time in less than 60 ms. Assuming the application uses 3 banks, that means individual acquisition must be reported in less than 20 ms. If moreover a debounce filter is used (set to 2), this time constraint must be divided further by a factor of 3. This leads to a maximum target time for one acquisition equal to 6.6 ms.

One acquisition time = count number x transfer cycle duration (see "transfer cycle duration" formula above)

4.4 Threshold adjustment

Two thresholds can be adjusted:

- DETECT_IN is the threshold to set a detection, it is recommended to set it to 2/3 of delta signal while touched with a normalized finger.
- DETECT_OUT is the threshold to reset a detection, this thresholds is set to 1/3 of delta signal.

Example: if delta when there is a touch is 150 counts: set TSLPRM_TKEY_DETECT_IN_TH to 100 and TSLPRM_TKEY_DETECT_OUT_TH to 50.

Those value can be adjusted knowing they are a compromise between these 2 requirements:

- avoid false detection on untouched adjacent key sensors
- avoid detection loss.

4.5 SW filter (debounce)

The SW filter allows to reduce the false detections or detection losses. It is configured with parameters: TSLPRM_DEBOUNCE_DETECT and TSLPRM_DEBOUNCE_RELEASE. Setting the parameter TSLPRM_DEBOUNCE_DETECT to 2 means that 3 consecutive acquisitions with a touch detected are needed to report a touch detection.

There is a trade-off. Increasing this parameter results in a longer response time between when a user touch change occurs and when it is actually reported to the system.

5 STM32303C-EVAL board example

5.1 Firmware

The firmware used with the STM32303C-EVAL is the STM32F303_Ex01_2TKeys_EVAL and it belongs to the STM32F3xx STMTouch Library. The results provided in this section are obtained with the configuration values presented in [Table 3](#):

Table 3. User configuration settings related to immunity improvements

Parameter	configuration value
HCLK	48 MHz
TSLPRM_TKEY_DETECT_IN_TH	100
TSLPRM_TKEY_DETECT_OUT_TH	50
TSLPRM_DEBOUNCE_DETECT	2
TSLPRM_TSC_CTPH	1
TSLPRM_TSC_CTPL	1
TSLPRM_TSC_PGPSC	5
TSLPRM_TSC_USE_SS	1
TSLPRM_TSC_SSD	127

5.2 Performance

Here are the performances of an **STM32303C-EVAL board**, with the configuration described above:

- Acquisition is performed in 1200 counts
- Acquisition duration: 4.7 ms (target < 6.6 ms)

5.3 Conducted noise evaluation

Here are the conducted noise evaluation results performed on **STM32303C-EVAL board** according to IEC61000-4-6 standard:

- **Pass 3 Vrms class A**

The test conditions for the above result are:

- Frequency range from 150 kHz to 80 MHz
- 1 % frequency steps
- Dwell time 0.5 s

Here are more accurate test results on worst case bandwidth: no false detection or loss observed up to **4 Vrms**, from 200 to 400 kHz with 100 Hz steps.

6 Conclusion

On STM32F0, STM32F3 and STM32L0 series of microcontrollers, the touch sensing controller peripheral shows a high noise immunity level in compliance with IEC61000-4-6 standard (above 3 Vrms class A). These results can easily be reached by putting in practice the following recommendations:

- Implement an Active Shield electrode and enable the Active Shield feature in the firmware.
- Enable the Spread Spectrum feature in the firmware.
- Optimize the detection thresholds.
- Use the debounce filter.

7 Revision history

Table 4. Document revision history

Date	Revision	Changes
03-Jul-2013	1	Initial release.
11-Jun-2014	2	Added support for STM32L0 series. Updated last bullet in Section 4.1: Proposed improvement techniques .

Please Read Carefully:

Information in this document is provided solely in connection with ST products. STMicroelectronics NV and its subsidiaries ("ST") reserve the right to make changes, corrections, modifications or improvements, to this document, and the products and services described herein at any time, without notice.

All ST products are sold pursuant to ST's terms and conditions of sale.

Purchasers are solely responsible for the choice, selection and use of the ST products and services described herein, and ST assumes no liability whatsoever relating to the choice, selection or use of the ST products and services described herein.

No license, express or implied, by estoppel or otherwise, to any intellectual property rights is granted under this document. If any part of this document refers to any third party products or services it shall not be deemed a license grant by ST for the use of such third party products or services, or any intellectual property contained therein or considered as a warranty covering the use in any manner whatsoever of such third party products or services or any intellectual property contained therein.

UNLESS OTHERWISE SET FORTH IN ST'S TERMS AND CONDITIONS OF SALE ST DISCLAIMS ANY EXPRESS OR IMPLIED WARRANTY WITH RESPECT TO THE USE AND/OR SALE OF ST PRODUCTS INCLUDING WITHOUT LIMITATION IMPLIED WARRANTIES OF MERCHANTABILITY, FITNESS FOR A PARTICULAR PURPOSE (AND THEIR EQUIVALENTS UNDER THE LAWS OF ANY JURISDICTION), OR INFRINGEMENT OF ANY PATENT, COPYRIGHT OR OTHER INTELLECTUAL PROPERTY RIGHT.

ST PRODUCTS ARE NOT AUTHORIZED FOR USE IN WEAPONS. NOR ARE ST PRODUCTS DESIGNED OR AUTHORIZED FOR USE IN: (A) SAFETY CRITICAL APPLICATIONS SUCH AS LIFE SUPPORTING, ACTIVE IMPLANTED DEVICES OR SYSTEMS WITH PRODUCT FUNCTIONAL SAFETY REQUIREMENTS; (B) AERONAUTIC APPLICATIONS; (C) AUTOMOTIVE APPLICATIONS OR ENVIRONMENTS, AND/OR (D) AEROSPACE APPLICATIONS OR ENVIRONMENTS. WHERE ST PRODUCTS ARE NOT DESIGNED FOR SUCH USE, THE PURCHASER SHALL USE PRODUCTS AT PURCHASER'S SOLE RISK, EVEN IF ST HAS BEEN INFORMED IN WRITING OF SUCH USAGE, UNLESS A PRODUCT IS EXPRESSLY DESIGNATED BY ST AS BEING INTENDED FOR "AUTOMOTIVE, AUTOMOTIVE SAFETY OR MEDICAL" INDUSTRY DOMAINS ACCORDING TO ST PRODUCT DESIGN SPECIFICATIONS. PRODUCTS FORMALLY ESCC, QML OR JAN QUALIFIED ARE DEEMED SUITABLE FOR USE IN AEROSPACE BY THE CORRESPONDING GOVERNMENTAL AGENCY.

Resale of ST products with provisions different from the statements and/or technical features set forth in this document shall immediately void any warranty granted by ST for the ST product or service described herein and shall not create or extend in any manner whatsoever, any liability of ST.

ST and the ST logo are trademarks or registered trademarks of ST in various countries.

Information in this document supersedes and replaces all information previously supplied.

The ST logo is a registered trademark of STMicroelectronics. All other names are the property of their respective owners.

© 2014 STMicroelectronics - All rights reserved

STMicroelectronics group of companies

Australia - Belgium - Brazil - Canada - China - Czech Republic - Finland - France - Germany - Hong Kong - India - Israel - Italy - Japan - Malaysia - Malta - Morocco - Philippines - Singapore - Spain - Sweden - Switzerland - United Kingdom - United States of America

www.st.com