



LM2954

LINEAR INTEGRATED CIRCUIT

300 mA LOW-DROPOUT VOLTAGE REGULATOR

DESCRIPTION

The UTC **LM2954** is a monolithic integrated voltage regulator with low dropout voltage, and low quiescent current. It includes many features that suitable for different applications with TO-92, DIP-8, SOP-8 and SOT-223 packages.

FEATURES

- *High Accuracy Fixed Output.
- *Output Voltage Programmable and Logic Controlled Shutdown And Error Flag Available for DIP and SOP Package.
- *Extremely Low Quiescent Current And Dropout Voltage.
- *Extremely Tight Load And Line Regulation.
- *Current and Thermal Limiting.
- *Very low Temperature Coefficient.

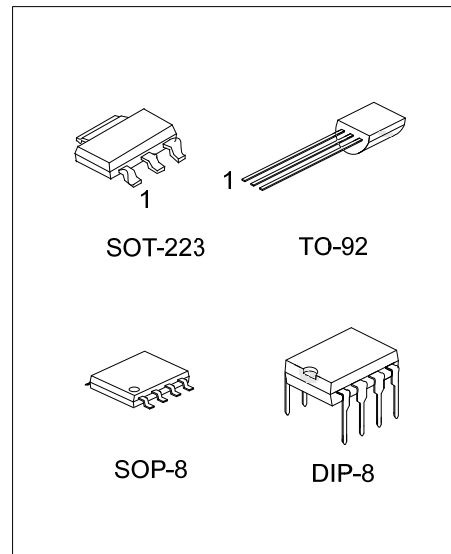

ORDERING INFORMATION

Order Number			Package	Pin assignment			Packing
Normal	Lead Free Plating	Halogen Free		1	2	3	
LM2954-xx-AA3-R	LM2954L-xx-AA3-R	LM2954G-xx-AA3-R	SOT-223	I	G	O	Tape Reel
LM2954-xx-D08-T	LM2954L-xx-D08-T	LM2954G-xx-D08-T	DIP-8	refer to Pin Configurations			Tube
LM2954-xx-S08-R	LM2954L-xx-S08-R	LM2954G-xx-S08-R	SOP-8				Tape Reel
LM2954-xx-S08-T	LM2954L-xx-S08-T	LM2954G-xx-S08-T	SOP-8				Tube
LM2954-xx-T92-B	LM2954L-xx-T92-B	LM2954G-xx-T92-B	TO-92	O	G	I	Tape Box
LM2954-xx-T92-K	LM2954L-xx-T92-K	LM2954G-xx-T92-K	TO-92	O	G	I	Bulk

Note: 1. Pin assignment: I: Vin O: V_{OUT} G: GND
2. xx: Output Voltage

<p>LM2954L-xx-AA3-R</p>	<p>(1) B: Tape Box, K: Bulk, R: Tape Reel, T: Tube (2) AA3: SOT-223, D08: DIP-08, S08: SOP-8, T92: TO-92 (3) xx: 3.3V:33, 5.0V:50, ADJ:AD (4) L: Lead Free Plating, Blank: Pb/Sn G: Halogen Free</p>
-------------------------	--

MARKING INFORMATION

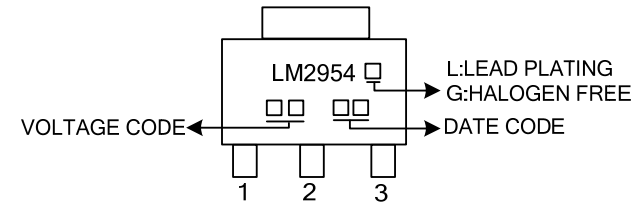
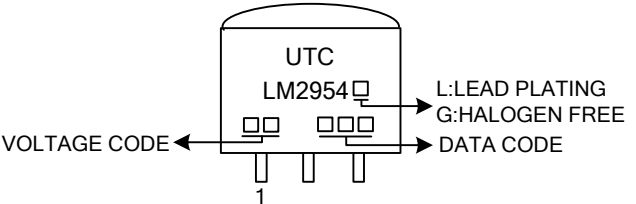
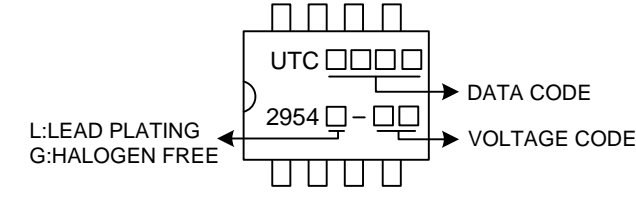
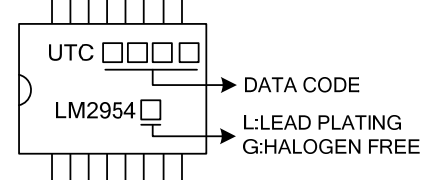
PACKAGE	VOLTAGE CODE	MARKING
SOT-223	33:3.3V 50:5.0V	 <p>Diagram of SOT-223 package marking: The package is a small surface-mount component with three pins labeled 1, 2, and 3. Markings include 'LM2954' in the center, 'VOLTAGE CODE' on the left, and 'L:LEAD PLATING', 'G:HALOGEN FREE', and 'DATE CODE' on the right.</p>
TO-92	3.3:3.3V 5.0:5.0V	 <p>Diagram of TO-92 package marking: The package is a small through-hole component with three pins, the first labeled '1'. Markings include 'UTC' and 'LM2954' in the center, 'VOLTAGE CODE' on the left, and 'L:LEAD PLATING', 'G:HALOGEN FREE', and 'DATE CODE' on the right.</p>
SOP-8/DIP-8	3.3:3.3V 5.0:5.0V	 <p>Diagram of SOP-8/DIP-8 package marking (top): The package is an 8-pin component. Markings include 'UTC' and '2954' in the center, 'L:LEAD PLATING', 'G:HALOGEN FREE' on the left, and 'DATA CODE' and 'VOLTAGE CODE' on the right.</p>
	ADJ	 <p>Diagram of SOP-8/DIP-8 package marking (bottom): The package is an 8-pin component. Markings include 'UTC' and 'LM2954' in the center, 'DATA CODE' on the right, and 'L:LEAD PLATING', 'G:HALOGEN FREE' on the left.</p>

■ PIN CONFIGURATIONS

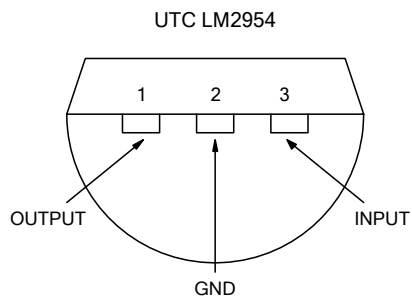

TO-92 Plastic Package Bottom View

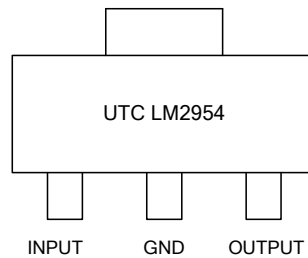

SOT-223 Package

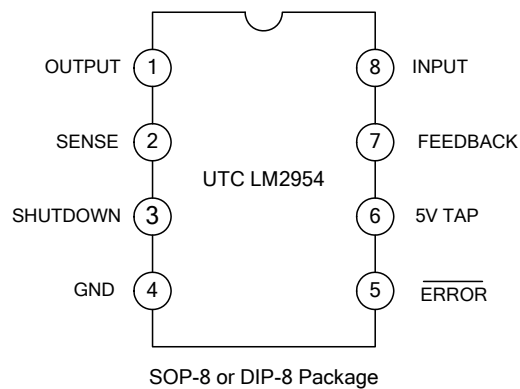

■ BLOCK DIAGRAM

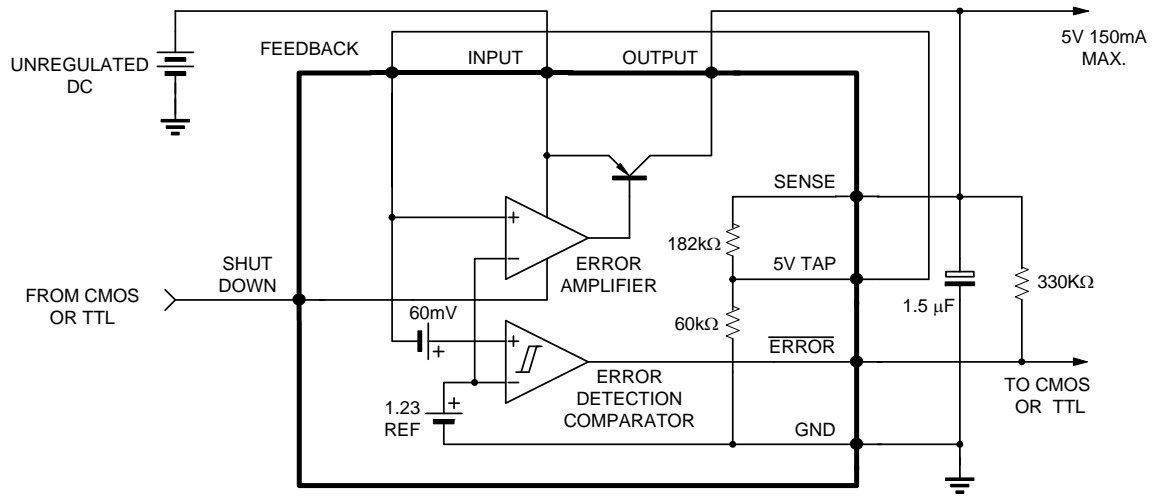

■ ABSOLUTE MAXIMUM RATINGS

PARAMETER	SYMBOL	VALUE	UNIT
Supply Voltage	V_{CC}	-0.3 ~ +30	V
Feedback Voltage	V_{FB}	-1.5 ~ +30	V
Shutdown Voltage	V_{SHDN}	-0.3 ~ +30	V
Comparator Output Voltage	V_{OUT}	-0.3 ~ +30	V
Junction Temperature	T_J	+125	°C
Operating Temperature	T_{OPR}	-40 ~ +85	°C
Storage temperature	T_{STG}	-40 ~ +150	°C

Note: 1. Absolute maximum ratings are those values beyond which the device which the device could be permanently damaged. Absolute maximum ratings are stress ratings only and functional device operation is not implied.

2. The device is guaranteed to meet performance specification within 0°C~+70°C operating temperature range and assured by design from -20°C~+85°C, characteristic and correlation with static process control.

■ ELECTRICAL CHARACTERISTICS ($T_J=25^\circ\text{C}$, $V_{IN}=6\text{V}$, $I_L=100\mu\text{A}$, $C_L=1\mu\text{F}$, unless otherwise specified)

PARAMETER	SYMBOL	TEST CONDITIONS	MIN.	TYP.	MAX.	UNIT
Output Voltage	V_{OUT}	$T_J=25^\circ\text{C}$	3.23	3.3	3.37	V
			4.90	5.0	5.10	
Output Voltage Temperature Coefficient	$T_C V_O$		20		100	ppm/°C
Line Regulation	ΔV_{OUT}	$6\text{V} \leq V_{IN} \leq 30\text{V}$		0.1	0.2	%
Load Regulation	ΔV_{OUT}	$100\mu\text{A} \leq I_L \leq 300\text{mA}$		0.2	0.5	
Dropout Voltage	V_D	$I_L=100\text{mA}$			400	mV
		$I_L=200\text{mA}$ (note 2)	380	450	600	
Ground Current	I_{GND}	$I_L=100\mu\text{A}$	0.075	0.12	0.23	mA
		$I_L=200\text{mA}$	8	12	14	
Dropout Ground Current	I_D	$V_{IN}=4.5\text{V}, I_L=100\mu\text{A}$			230	μA
Current Limit	I_{LIMIT}	$V_{OUT}=0$	300			mA
Output Noise (10Hz to 100KHz)	eN	$C_L=1\mu\text{F}$			430	μV
		$C_L=200\mu\text{F}$			160	
		$C_L=3.3\mu\text{F}$			100	
LM2954-ADJ For 8-Pin Version Only						
Reference Voltage	V_{REF}		1.22	1.235	1.25	V
Reference Voltage	V_{REF}	$V_{REF} \leq V_{OUT} \leq (V_{IN}-1\text{V})$, $2.3\text{V} \leq V_{IN} \leq 18\text{V}$, $100\mu\text{A} \leq I_L \leq 100\text{mA}$, $T_J \leq T_{JMAX}$	1.19		1.27	V
Feedback Pin Bias Current	$I_{B(FB)}$			20	40	nA
Reference Voltage Temperature Coefficient	$T_C V_{REF}$			50		ppm/°C
Feedback Bias Current Temperature Coefficient	$T_{C I_O}$			0.1		nA/°C

■ ELECTRICAL CHARACTERISTICS(Cont.)

PARAMETER	SYMBOL	TEST CONDITIONS	MIN.	TYP.	MAX.	UNIT
Error Comparator						
Output Leakage Current	$I_{O(LEAK)}$	$V_{OH}=30V$			1	μA
Output Low Voltage	V_{OL}	$V_{IN}=4.5V, I_{OL}=400\mu A$			250	mV
Upper Threshold Voltage	$V_{THD(UP)}$	(Note 3)	3.2			$\%V_{OUT}$
Lower Threshold Voltage	$V_{THD(LOW)}$	(Note 3)			7.6	$\%V_{OUT}$
Hysteresis	V_{HYS}	(Note 3)		15		mV
Shutdown Input						
Input Logic Voltage	$V_{I(LOG)}$	Low (Regulator ON)		1.3	0.70	V
		High (Regulator OFF)	2.0			
Shutdown Pin Input Current	$I_{I(SHDN)}$	$V_{SHDN}=2.4V$		30	50	μA
		$V_{SHDN}=30V$		450	600	μA
Regulator Output Current Shutdown	$I_{O(SHDN)}$	$V_{SHDN} \geq 2V, V_{IN} \leq 30V, V_{OUT}=0,$ Feedback pin tied to 5V Tap.		3	10	μA

Note 1: Additional conditions for 8-pin versions are feedback tied to 5V Tap and Output tied to Output Sense ($V_{OUT}=5V$) and $V_{SHDN} \leq 0.8V$.

Note 2: Dropout voltage is defined as the input to output differential at which the output voltage drops 100mV below its nominal value measured at 1V differential.

Note 3: Comparator thresholds are expressed in terms of percentage value of voltage output.

APPLICATION CIRCUIT (10A Low Dropout Regulator)

For 8 Pins

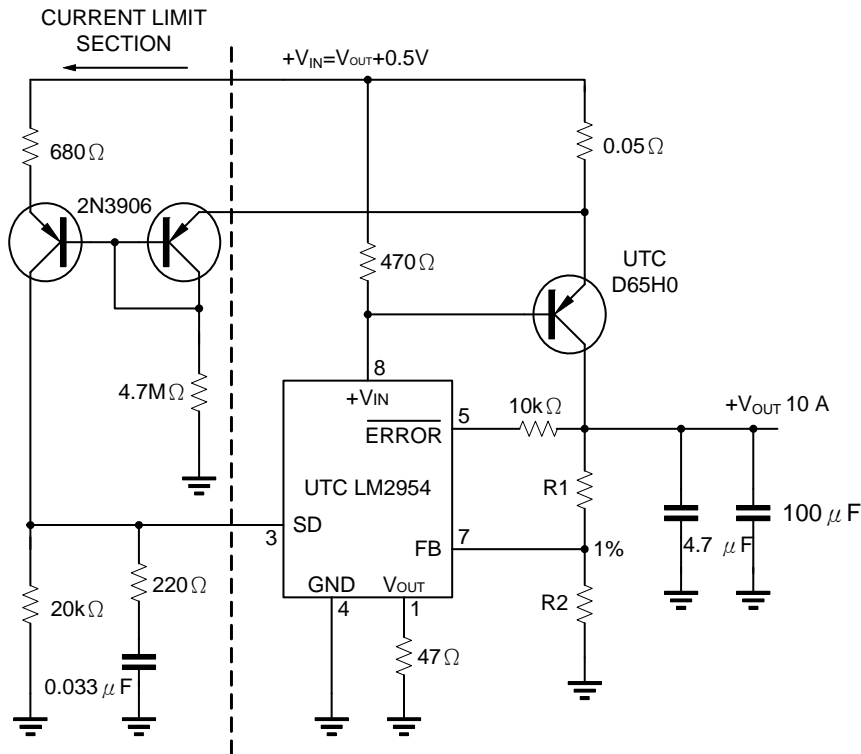

$$V_{OUT} = 1.23V * (1 + R1/R2)$$

For 5V output use internal resistors. Wire pin 6 to 7 and wire pin 2 to +Vout

For 3 Pins

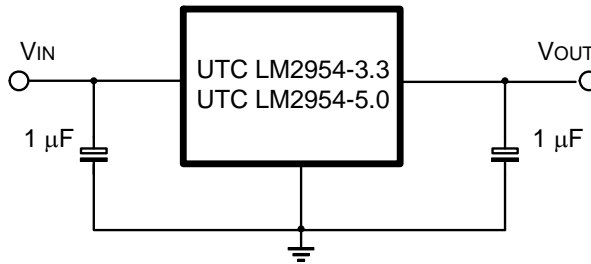

UTC assumes no responsibility for equipment failures that result from using products at values that exceed, even momentarily, rated values (such as maximum ratings, operating condition ranges, or other parameters) listed in products specifications of any and all UTC products described or contained herein. UTC products are not designed for use in life support appliances, devices or systems where malfunction of these products can be reasonably expected to result in personal injury. Reproduction in whole or in part is prohibited without the prior written consent of the copyright owner. The information presented in this document does not form part of any quotation or contract, is believed to be accurate and reliable and may be changed without notice.