

UNCONTROLLED DOCUMENT

PART NUMBER
SSI-LXH600BUSBD150

REV.

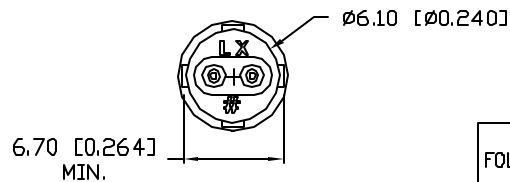
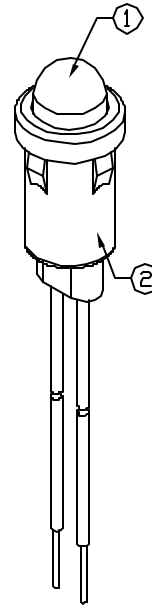
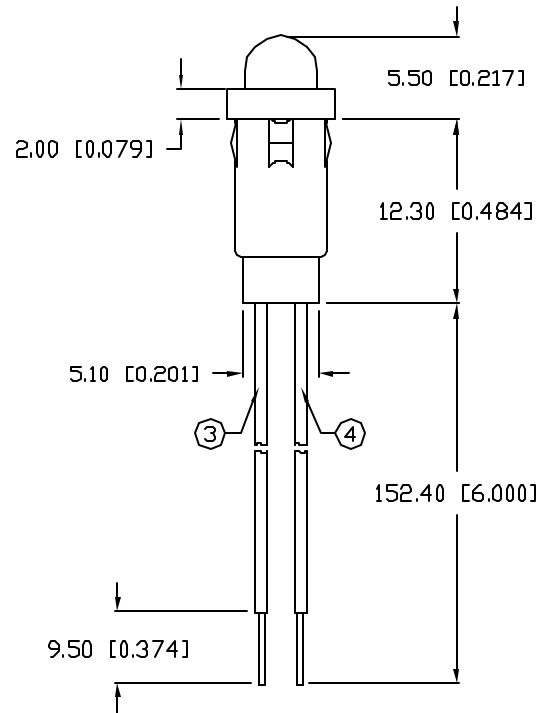
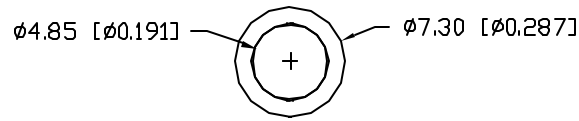

PANEL HOLE: $\varnothing 0.250''$
PANEL THICKNESS: 0.030" MIN.

CAUTION: STATIC SENSITIVE DEVICE
FOLLOW PROPER E.S.D. HANDLING PROCEDURES
WHEN WORKING WITH THIS PART.

ELECTRO-OPTICAL CHARACTERISTICS $T_A=25^\circ\text{C}$

PARAMETER	MIN	TYP	MAX	UNITS	TEST COND
PEAK WAVELENGTH		470		nm	
FORWARD VOLTAGE		5.0	14.0	V_f	
BLINKING FREQUENCY:		1.5		Hz	$V_f=14.0, I_f=70\text{mA}$
		3.0		Hz	$V_f=3.5, I_f=6\text{mA}$
AXIAL INTENSITY		70		mod	$V_f=9.0$
VIEWING ANGLE		60		2x theta	
EMITTED COLOR:		BLUE			
EPOXY LENS FINISH:		BLUE DIFFUSED			

LIMITS OF SAFE OPERATION AT 25°C

PARAMETER	MAX	UNITS
PEAK FORWARD CURRENT*	70	mA
STEADY CURRENT	20	mA
POWER DISSIPATION	310	mW
DERATE FROM 25°C	-1.2	mW/ $^\circ\text{C}$
OPERATING, STORAGE TEMP.	-40 TO +85	$^\circ\text{C}$
SOLDERING TEMP.	+260	$^\circ\text{C}$
2.0mm FROM BODY		3 SEC. MAX

* $t < 10\mu\text{s}$

NOTES:

- SSL-LX509F3BUSBD LED.
- SSH-LXH600 HOLDER, BLACK.
- ANODE LEAD: LXP-WST24RDTC, 24 AWG STRANDED, TOP OVERCOAT, RED INSULATION, CUT 160mm LONG, STRIP 4mm & 9.5mm.
- CATHODE LEAD: LXP-WST24BLTC, 24 AWG STRANDED, TOP OVERCOAT, BLACK INSULATION, CUT 160mm LONG, STRIP 4mm & 9.5mm.



UNCONTROLLED DOCUMENT

*UNLESS OTHERWISE SPECIFIED TOLERANCES PER DECIMAL PRECISION ARE: X= ± 1 (± 0.039), XX= ± 0.5 (± 0.020), XXX= ± 0.25 (± 0.010), XXXX= ± 0.127 (± 0.005). LEAD SIZE= ± 0.05 (± 0.002), LEAD LENGTH= ± 0.75 (± 0.030), MIN= $\frac{+0.00}{-0.00}$ DECIMAL PRECISION, MAX= $\frac{+0.00}{-0.00}$ DECIMAL PRECISION

REV.

PART NUMBER

SSI-LXH600BUSBD150

CONFIDENTIAL INFORMATION
THE INFORMATION CONTAINED IN THIS DOCUMENT IS THE PROPERTY OF LUMEX INC. EXCEPT AS SPECIFICALLY AUTHORIZED IN WRITING BY LUMEX INC, THE HOLDER OF THIS DOCUMENT SHALL KEEP ALL INFORMATION CONTAINED HEREIN CONFIDENTIAL AND SHALL PROTECT SAME IN WHOLE OR IN PART FROM DISCLOSURE AND DISSEMINATION TO ALL THIRD PARTIES.



290 E. HELEN ROAD
PALATINE, IL 60067-6976
PHONE: +1.847.359.2790
US WEB: www.lumex.com
TW WEB: www.lumex.com.tw

T-5mm (T-1 3/4) LED, PANEL MOUNT INDICATOR,
BLINKING 470nm ULTRA SUPER BLUE LED,
BLUE DIFFUSED LENS, WITH 6" WIRE LEADS.

RELIABILITY NOTE
OUR MANY YEARS OF EXPERIENCE DATA ACCUMULATION INDICATE THAT SOLDER HEAT IS A MAJOR CAUSE OF EARLY AND FUTURE FAILURE. PLEASE PAY ATTENTION TO YOUR SOLDERING PROCESS.

DRAWN BY: JN	CHECKED BY:	APPROVED BY:	DATE: 01.14.08
			PAGE: 1 OF 1
			SCALE: N/A