

Features
<ul style="list-style-type: none"> <li>±20ppm (Frequency Stability) Available</li> <li>Low Phase Noise and Jitter Performance</li> <li>Tape and Reel</li> </ul>

Applications
<ul style="list-style-type: none"> <li>High Definition TV</li> <li>Avionics</li> <li>Low Phase Signal Sources</li> <li>Test and Measurement Equipment</li> </ul>

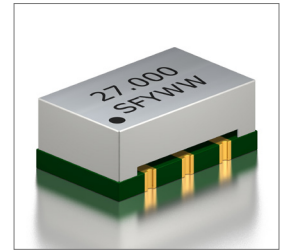

### Part Numbering Guide

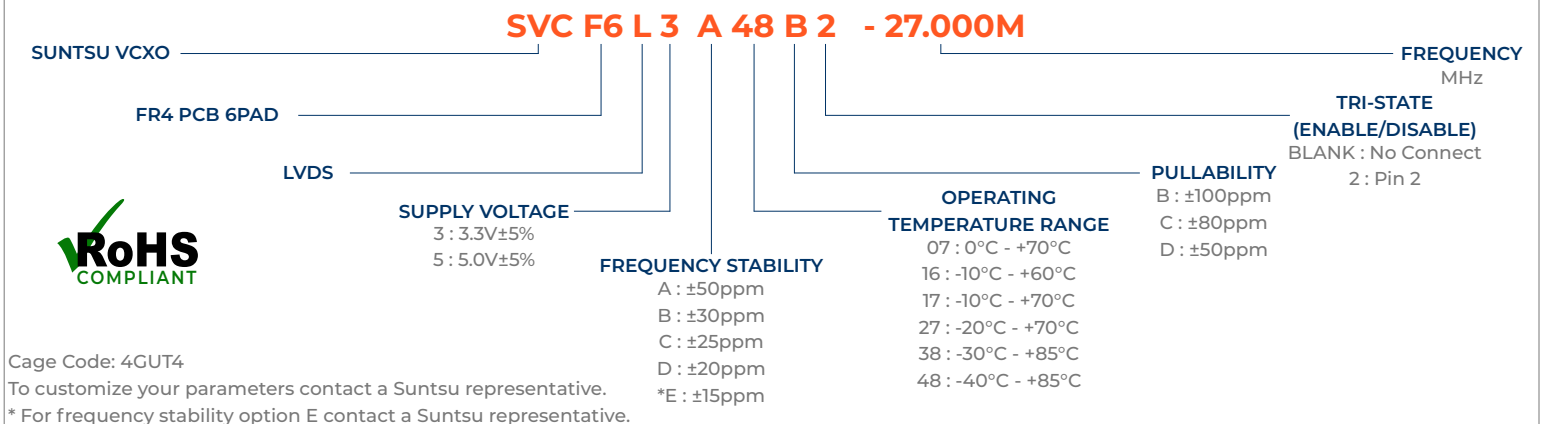

Cage Code: 4GUT4  
 To customize your parameters contact a Suntsu representative.  
 \* For frequency stability option E contact a Suntsu representative.

Electrical Parameters	Units	Minimum	Typical	Maximum	Remarks
Frequency Range	MHz	10		800	
Frequency Stability (Includes Initial Tolerance at 25°C, Frequency Stability over Op Temp, Output Load Change, Supply Voltage Change, and First Year Aging at 25°C.)	ppm	-20		+20	See part numbering guide for options.
Operating Temperature	°C	-40		+85	See part numbering guide for options.
Storage Temperature	°C	-45		+90	
Supply Voltage (V <sub>DD</sub> ) 3.3V Option	V	3.135	3.3	3.465	
Supply Voltage (V <sub>DD</sub> ) 5.0V Option	V	4.750	5.0	5.250	
Current (I <sub>DD</sub> ) 3.3V Option	mA			70	
Current (I <sub>DD</sub> ) 5.0V Option	mA			100	
Current Voltage (V <sub>c</sub> ) 3.3V Option	V	0.15		3.15	
Current Voltage (V <sub>c</sub> ) 5.0V Option	V	0.0		5.0	
Pullability	ppm	±50		±100	See part numbering guide for options.
Input Impedance	kΩ			51	
Modulation Bandwidth	kHz	10			@-3dB
Linearity	%			10	
Output Load (LVDS)	Ω			100	
Output Logic HIGH Level (V <sub>OH</sub> )	V		1.43	1.6	
Output Logic LOW Level (V <sub>OL</sub> )	V	0.9	1.1		
Differential Output Voltage (V <sub>OD</sub> )	mV	247	330	454	
Differential Output Error (ΔV <sub>OD</sub> )	mV			50	
Offset Voltage (V <sub>OS</sub> )	V	1.125	1.250	1.375	
Offset Error (ΔV <sub>OS</sub> )	mV			50	
Rise (T <sub>R</sub> ) And Fall (T <sub>F</sub> ) Time	ns			1	Measure at 20% to 80% of Waveform.
Symmetry (Duty Cycle)	%	45	50	55	
Tri-State Input Voltage - Enable	V	0.7*V <sub>DD</sub>			No Connection
Tri-State Input Voltage - Disable	V			0.3*V <sub>DD</sub>	
Start-Up Time	ms			10	
Phase Jitter (12KHz ~ 20MHz)	ps			1	

**Outline Drawing & Land Pattern**

All dimensions are in millimeters (mm) unless otherwise noted. Drawings are not to scale.

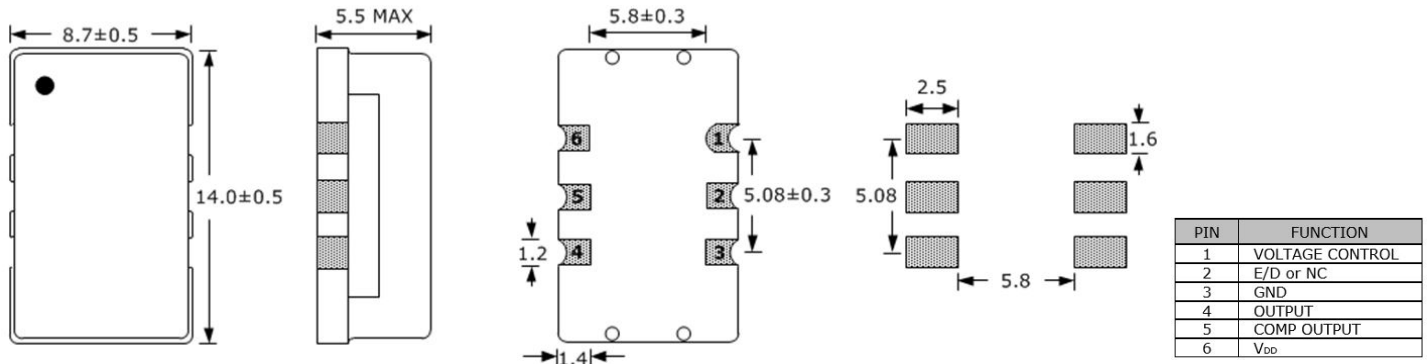
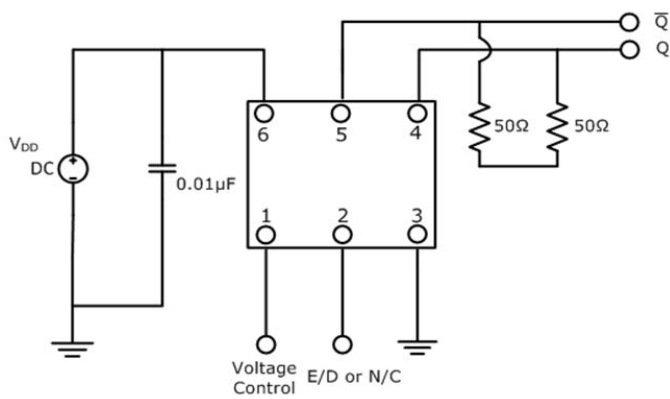
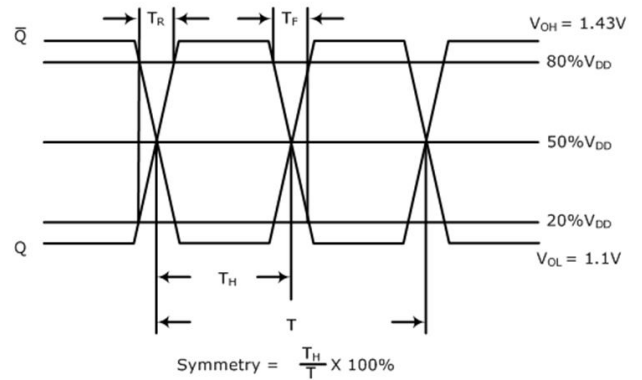
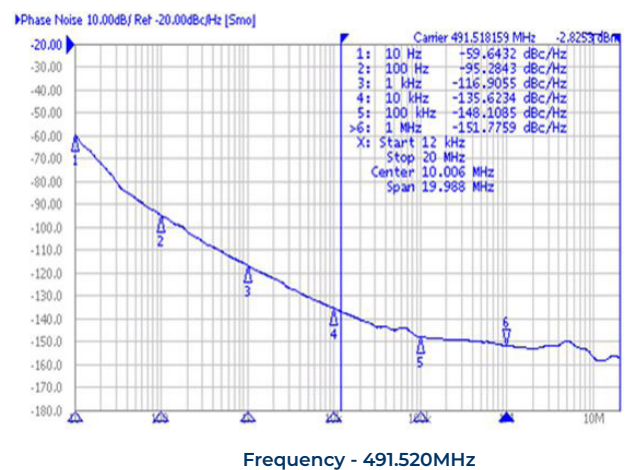
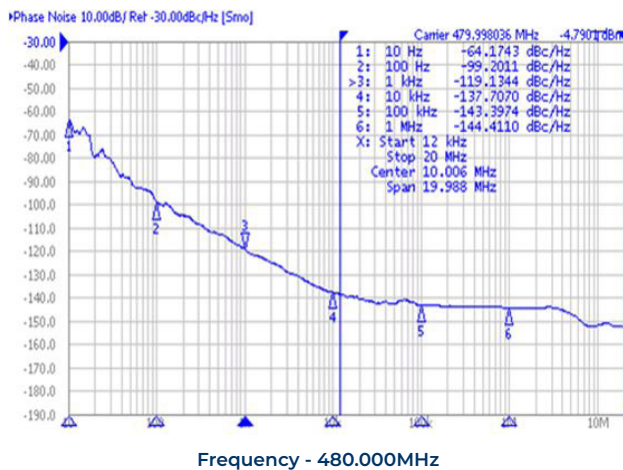
**Test Circuit (LVDS)**

**Waveform (LVDS)**

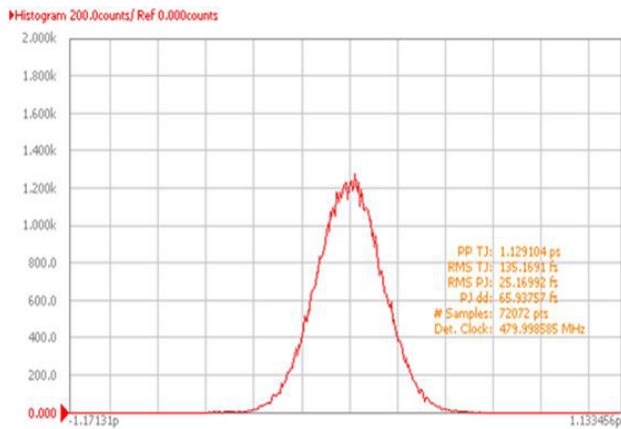
**Typical Phase Noise Performance (Measured By Agilent E5052A)**

Typical Jitter Performance (Measured By Agilent E5052A)

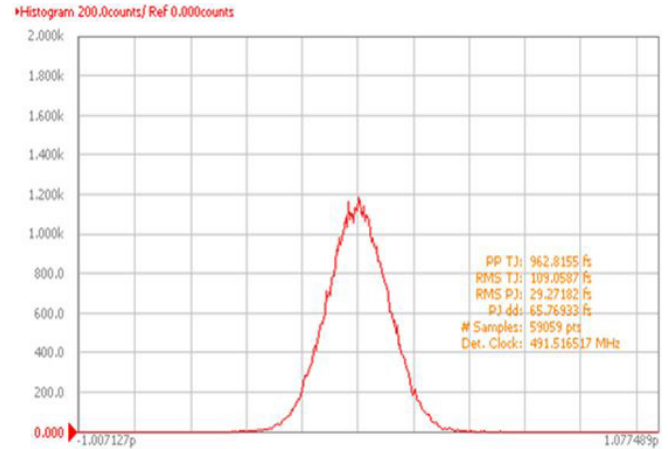

Frequency - 480.000MHz



Frequency - 491.520MHz

Reflow Profile

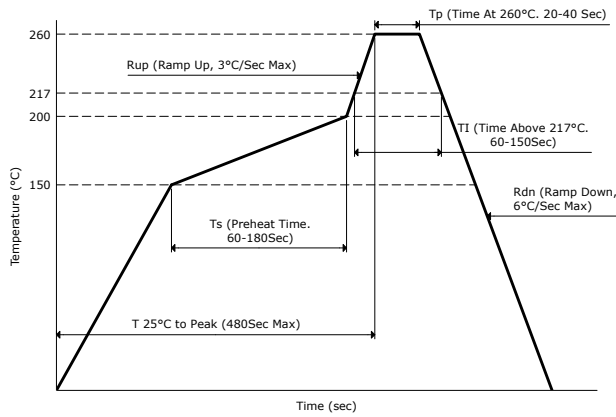

Part Marking

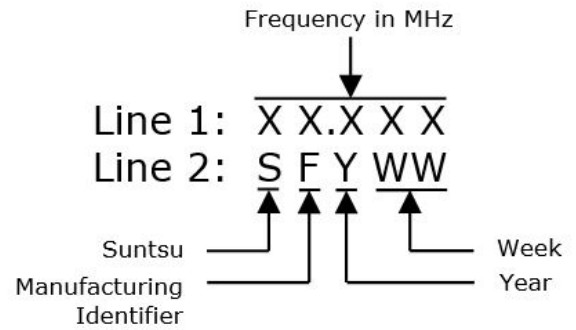

Tape And Reel Dimensions

All dimensions are in millimeters (mm) unless otherwise noted. Drawings are not to scale.

500pcs/Reel

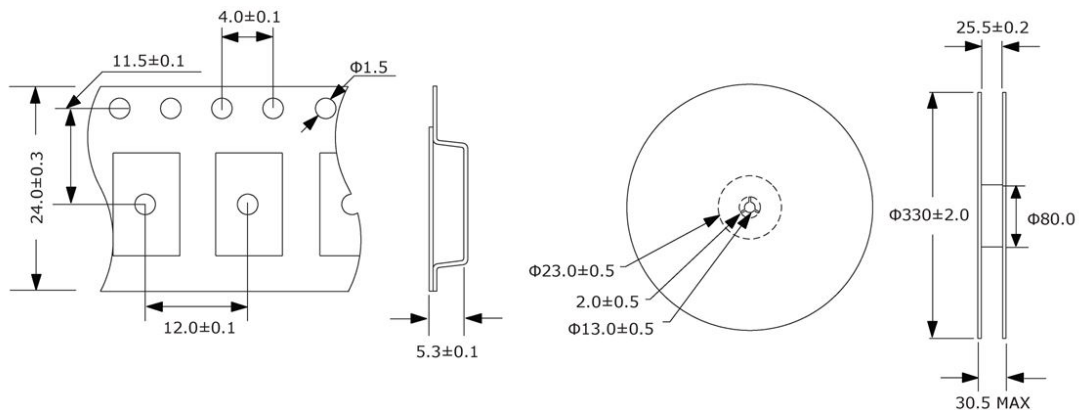

Environmental Specifications		Mechanical Specifications	
Temperature Cycling	MIL-STD-883, Method 1010, Condition B	Mechanical Shock	MIL-STD-202, Method 213, Condition B
Fine Leak Test	MIL-STD-883, Method 1014, Condition A	Vibration	MIL-STD-883, Method 2007, Condition A
Gross Leak Test	MIL-STD-883, Method 1014, Condition C	Moisture Resistance	MIL-STD-883, Method 1004
Solderability	MIL-STD-883, Method 2003	Resistance to Solvents	MIL-STD-202, Method 215
Moisture Sensitivity	J-STD-020, MSL 1	Resistance to Soldering Heat	MIL-STD-202, Method 210, Condition K