

Specification of MEMS Microphone (RoHS Compliance & Halogen Free)

Customer Name :

Customer Model :

GoerTek Model : S08OB381-026

GoerTek	CUSTOMER APPROVAL												
<table style="width: 100%; border-collapse: collapse;"> <tr> <td style="width: 20%;"><u>DESIGN</u></td> <td style="width: 50%;"><u>Jasen</u></td> <td style="width: 30%; text-align: right;">2017.03.31</td> </tr> <tr> <td><u>CHKD</u></td> <td><u>Sweety</u></td> <td style="text-align: right;">2017.03.31</td> </tr> <tr> <td><u>STANDARD</u></td> <td><u>Chloe</u></td> <td style="text-align: right;">2017.03.31</td> </tr> <tr> <td><u>APVD</u></td> <td><u>Mars</u></td> <td style="text-align: right;">2017.03.31</td> </tr> </table>	<u>DESIGN</u>	<u>Jasen</u>	2017.03.31	<u>CHKD</u>	<u>Sweety</u>	2017.03.31	<u>STANDARD</u>	<u>Chloe</u>	2017.03.31	<u>APVD</u>	<u>Mars</u>	2017.03.31	
<u>DESIGN</u>	<u>Jasen</u>	2017.03.31											
<u>CHKD</u>	<u>Sweety</u>	2017.03.31											
<u>STANDARD</u>	<u>Chloe</u>	2017.03.31											
<u>APVD</u>	<u>Mars</u>	2017.03.31											



E- Mail : goertek@goertek.com
 Website: <http://www.goertek.com>
 Address: No.268 Dongfang Road, High-Tech Industry
 Development District, Weifang, Shandong, P.R.C.

1 Security Warning

The information contained in this document is the exclusive property of GoerTek Inc. and should not be disclosed to any third party without the written consent of GoerTek Inc.

2 Publication History

Version	Description	Date	Author	Approved
1.0	New Design	2015.06.30	Reddy	Worden
2.0	Update Appearance Drawing	2016.11.18	Jasen	Mars
3.0	Update Reliability Condition	2017.03.31	Jasen	Mars

Contents

1	Introduction	4
2	Test Condition	4
3	Acoustic and Electrical Characteristics	4
4	Frequency Response Curve	4
5	Measurement Circuit	5
6	Test Setup Drawing	5
7	Mechanical Characteristics	6
7.1	Appearance Drawing	6
7.2	Weight	6
8	Reliability Condition	7
8.1	Vibration Test	7
8.2	Drop Test	7
8.3	Temperature Test	7
8.4	Humidity Test	7
8.5	Mechanical Shock Test	7
8.6	Thermal Shock Test	7
8.7	Reflow Test	7
8.8	Electrostatic Discharge Test	7
8.9	Air Blow Test	7
9	Package	8
9.1	Tape Specification	8
9.2	Reel Dimension	9
9.3	The Content of Box	9
9.4	Packing Explain	10
10	Storage and Transportation	10
11	Land Pattern Recommendation	11
11.1	The Pattern of MIC Pad	11
11.2	Recommended Soldering Surface Land Pattern	11
12	Soldering Recommendation	12
12.1	Soldering Machine Condition	12
12.2	The Drawing and Dimension of Nozzle	12
12.3	Reflow Profile	13
13	Cautions When Using MEMS MIC	14
13.1	Board Wash Restrictions	14
13.2	Nozzle Restrictions	14
13.3	Ultrasonic Restrictions	14
14	Output Inspection Standard	14

1 Introduction

MEMS MIC which is able to endure reflow temperature up to 260 °C for 50 seconds can be used in SMT process. It is widely used in telecommunication and electronics device such as mobile phone, MP3, PDAs etc.

2 Test Condition (Vs=2.0V, L=50cm)

Standard Conditions (As IEC 60268-4)	Temperature	Humidity	Air pressure
Environment Conditions	+15°C ~ +35°C	25% R.H. ~ 75% R.H.	86kPa ~ 106kPa
Basic Test Conditions	+20°C ± 2°C	60% R.H. ~ 70% R.H.	86kPa ~ 106kPa

3 Acoustic and Electrical Characteristics

Item	Symbol	Test Conditions	Min	Typ	Max	Unit
Sensitivity	S	f=1kHz, Pin=1Pa	-39	-38	-37	dBV/Pa
Directivity	D(θ)	Omnidirectional				
Output Impedance	Zout	f=1kHz, Pin=1Pa			300	Ω
Operating Voltage Range	Vs	————	1.5	2.0	3.3	V
Current Consumption	I	————	50		250	μA
Decreasing Voltage Characteristic	ΔS	f=1kHz, Pin=1Pa Vs = 3.3 → 1.5V	No Change			dBV/Pa
S/N Ratio	S/N(A)	f=1kHz, Pin=1Pa (A-weighted)		62		dB
Total Harmonic Distortion	THD	110dB SPL@f=1 kHz			1	%

4 Frequency Response Curve and Limits

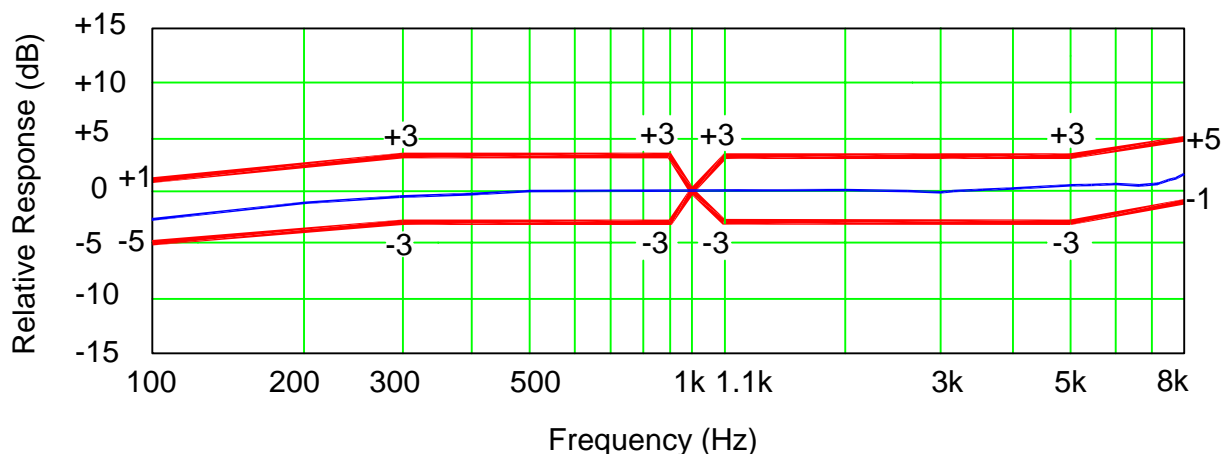

5 Measurement Circuit

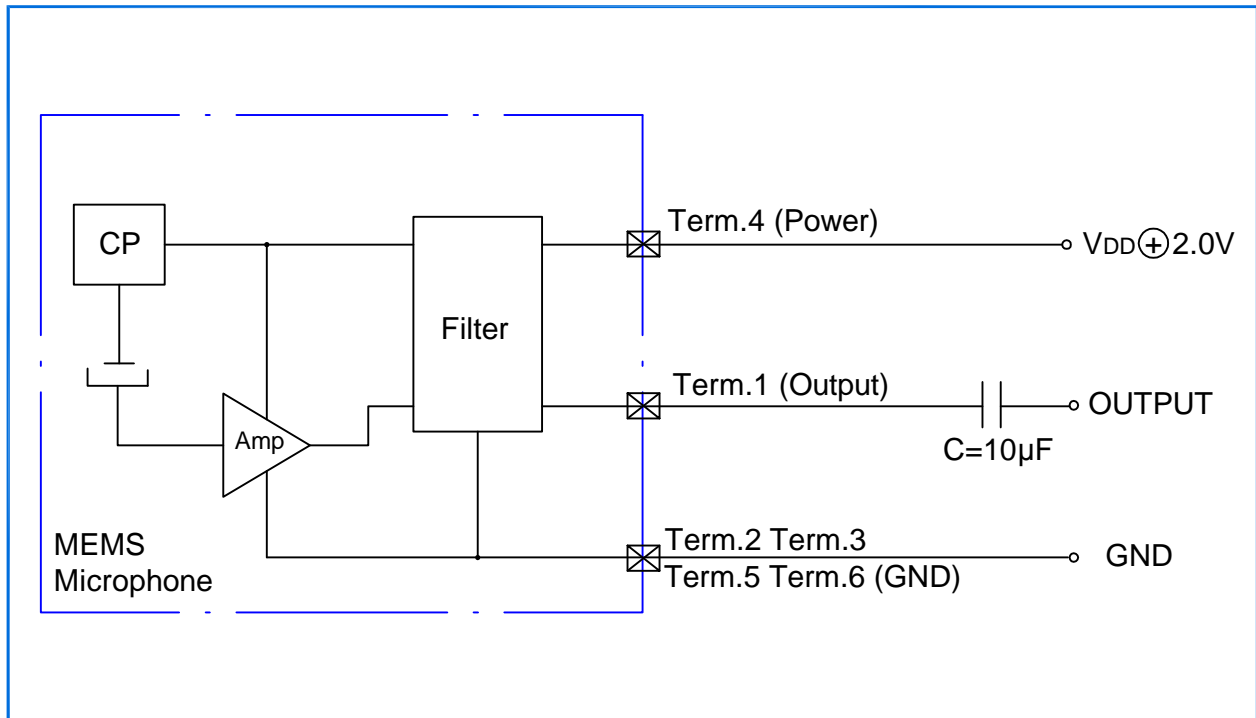

6 Test Setup Drawing

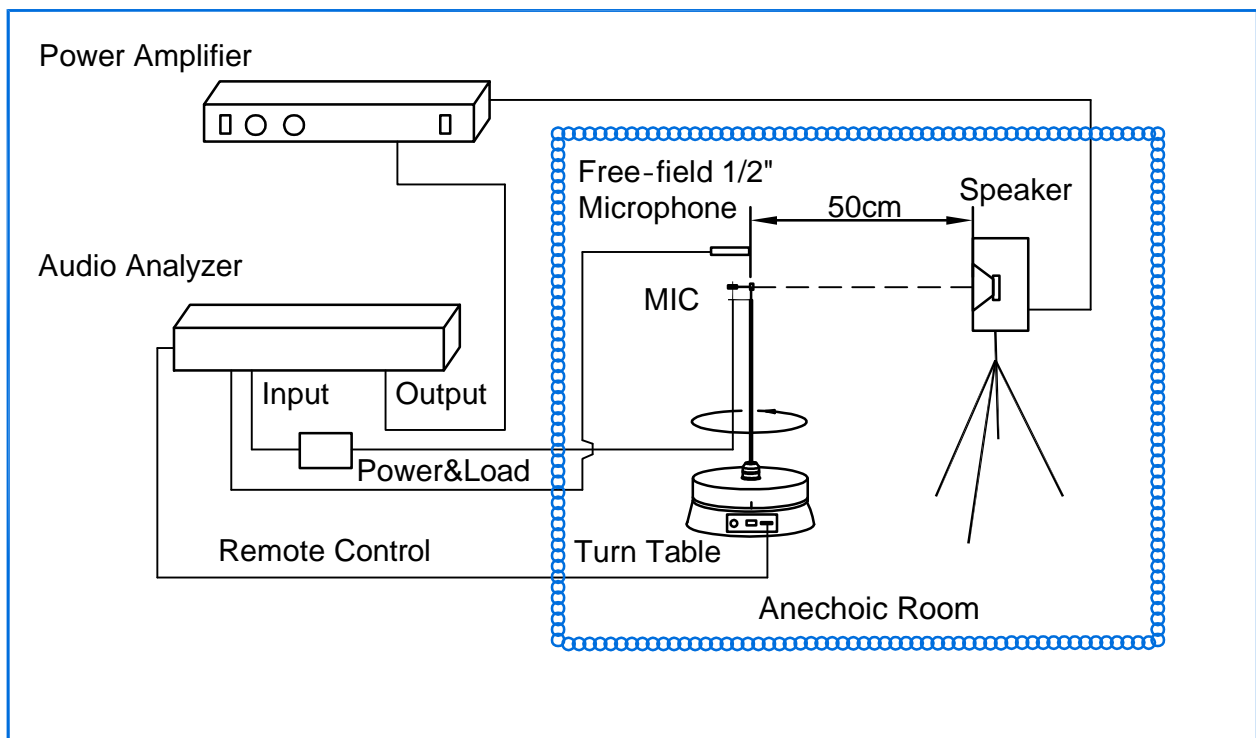

7 Mechanical Characteristics

7.1 Appearance Drawing (Unit: mm)

The drawing shows a microphone component with the following dimensions and features:

- Top View:** Overall length L , width W , and a central square area with a 2D code. The code is oriented upside down and reads "G W W D" and "Y L L L". The distance from the left edge to the code is 2.61 . The radius of the top corners is $R 0.28$.
- Bottom View:** Shows six pins numbered 1 through 6. Pin 1 is at the top right, pin 2 at the bottom right, pin 3 at the bottom left, pin 4 at the top left, pin 5 at the top center, and pin 6 at the bottom center. Dimensions include a total width of 2.04 for the pin area, a distance of 0.48 from the left edge to the start of the pin area, and a distance of 0.49 from the bottom edge to the start of the pin area. Pin diameters are $2 \times \text{Ø}0.56$. A central acoustic port (AP) has a diameter of $\text{Ø}0.25$. Other features include a "Mark" with a diameter of $\text{Ø}0.61$ and a distance of 1.93 from the top edge, and two holes with a diameter of $2 \times \text{Ø}0.72$. The distance from the top edge to the top of the pin area is 0.535 , and the distance from the top edge to the top of the acoustic port is 2.1 . The distance from the top edge to the top of the bottom-most pin is 2.74 .
- Side View:** Shows a height of 3.4 and a radius of $R 0.25$ at the bottom.

Pin Output Table:

Pin Output		Item	Dimension	Tol.(±)	Units
Pin#	Function	Length	3.76	0.10	mm
1	Output	Width	3.00	0.10	mm
2 3	GND	Height	1.10	0.10	mm
5 6	GND	Acoustic Port (AP)	$\text{Ø}0.25$	0.05	mm
4	Power				

Note:

- Tolerance $\pm 0.10\text{mm}$ unless otherwise specified.
- Identification Number Convention: Job Identification Number.

Identification Number:

G	W	W	D	G	: GoerTek	W	W	: Week	D	: Day	2D Code
Y	L	L	L	Y	: Year	L	L	: Lot Number			

7.2 Weight

The weight of the MIC is Less than 0.04g.

8 Reliability Condition

<p>8.1 Vibration Test</p>	<p>To be no interference in operation after vibrations, 4 cycles, from 20 to 2,000Hz in each direction(X,Y,Z), 48 minutes, using peak acceleration of 20g, sensitivity should vary within $\pm 3\text{dB}$ from initial sensitivity. (The measurement to be done after 2 hours of conditioning at $+15^{\circ}\text{C} \sim +35^{\circ}\text{C}$, R.H.25% \sim 75%)</p>
<p>8.2 Drop Test</p>	<p>To be no interference in operation after dropped to 1.0cm steel plate 12 times from 1.5 meter height in state of JIG, JIG weight of 100g, sensitivity should vary within $\pm 3\text{dB}$ from initial sensitivity. (The measurement to be done after 2 hours of conditioning at $+15^{\circ}\text{C} \sim +35^{\circ}\text{C}$, R.H.25% \sim 75%)</p>
<p>8.3 Temperature Test</p>	<p>a) After exposure at $+125^{\circ}\text{C}$ for 200 hours, sensitivity should vary within $\pm 3\text{dB}$ from initial sensitivity. (The measurement to be done after 2 hours of conditioning at $+15^{\circ}\text{C} \sim +35^{\circ}\text{C}$, R.H.25% \sim 75%) b) After exposure at -40°C for 200 hours, sensitivity should vary within $\pm 3\text{dB}$ from initial sensitivity. (The measurement to be done after 2 hours of conditioning at $+15^{\circ}\text{C} \sim +35^{\circ}\text{C}$, R.H.25% \sim 75%)</p>
<p>8.4 Humidity Test</p>	<p>After exposure at $+85^{\circ}\text{C}$ and 85% relative humidity for 200 hours, sensitivity should vary within $\pm 3\text{dB}$ from initial sensitivity. (The measurement to be done after 2 hours of conditioning at $+15^{\circ}\text{C} \sim +35^{\circ}\text{C}$, R.H.25% \sim 75%)</p>
<p>8.5 Mechanical Shock Test</p>	<p>Then subject samples to three one-half sine shock pulses (3000 g for 0.3 milliseconds) in each direction (for six axes in total) along each of the three mutually perpendicular axes for a total of 18 shocks, sensitivity should vary within $\pm 3\text{dB}$ from initial sensitivity. (The measurement to be done after 2 hours of conditioning at $+15^{\circ}\text{C} \sim +35^{\circ}\text{C}$, R.H.25% \sim 75%)</p>
<p>8.6 Thermal Shock Test</p>	<p>After exposure at -40°C for 30 minutes, at $+125^{\circ}\text{C}$ for 30 minutes (change time 20 seconds) 32 cycles, sensitivity should vary within $\pm 3\text{dB}$ from initial sensitivity. (The measurement to be done after 2 hours of conditioning at $+15^{\circ}\text{C} \sim +35^{\circ}\text{C}$, R.H.25% \sim 75%)</p>
<p>8.7 Reflow Test</p>	<p>Adopt the reflow curve of item 12.3, after three reflows, sensitivity should vary within $\pm 2\text{dB}$ from initial sensitivity. (The measurement to be done after 2 hours of conditioning at $+15^{\circ}\text{C} \sim +35^{\circ}\text{C}$, R.H.25% \sim 75%)</p>
<p>8.8 Electrostatic Discharge Test</p>	<p>Under $C=150\text{pF}$, $R=330\text{ohm}$. Tested to $\pm 8\text{KV}$ contact to the case and tested to $\pm 2\text{kV}$ contact to I/O terminals.10 times. Grounding. Sensitivity should vary within $\pm 3\text{dB}$ from initial sensitivity. (The measurement to be done after 2 hours of conditioning at $+15^{\circ}\text{C} \sim +35^{\circ}\text{C}$, R.H.25% \sim 75%)</p>
<p>8.9 Air Blow Test</p>	<p>0.4MPa, 50mm, 10s, airgun diameter: 1mm, 20pcs. Sensitivity should vary within 3dB from initial sensitivity. (The measurement to be done after 2 hours of conditioning at $+15^{\circ}\text{C} \sim +35^{\circ}\text{C}$, R.H.25% \sim 75%)</p>

9 Package

9.1 Tape Specification

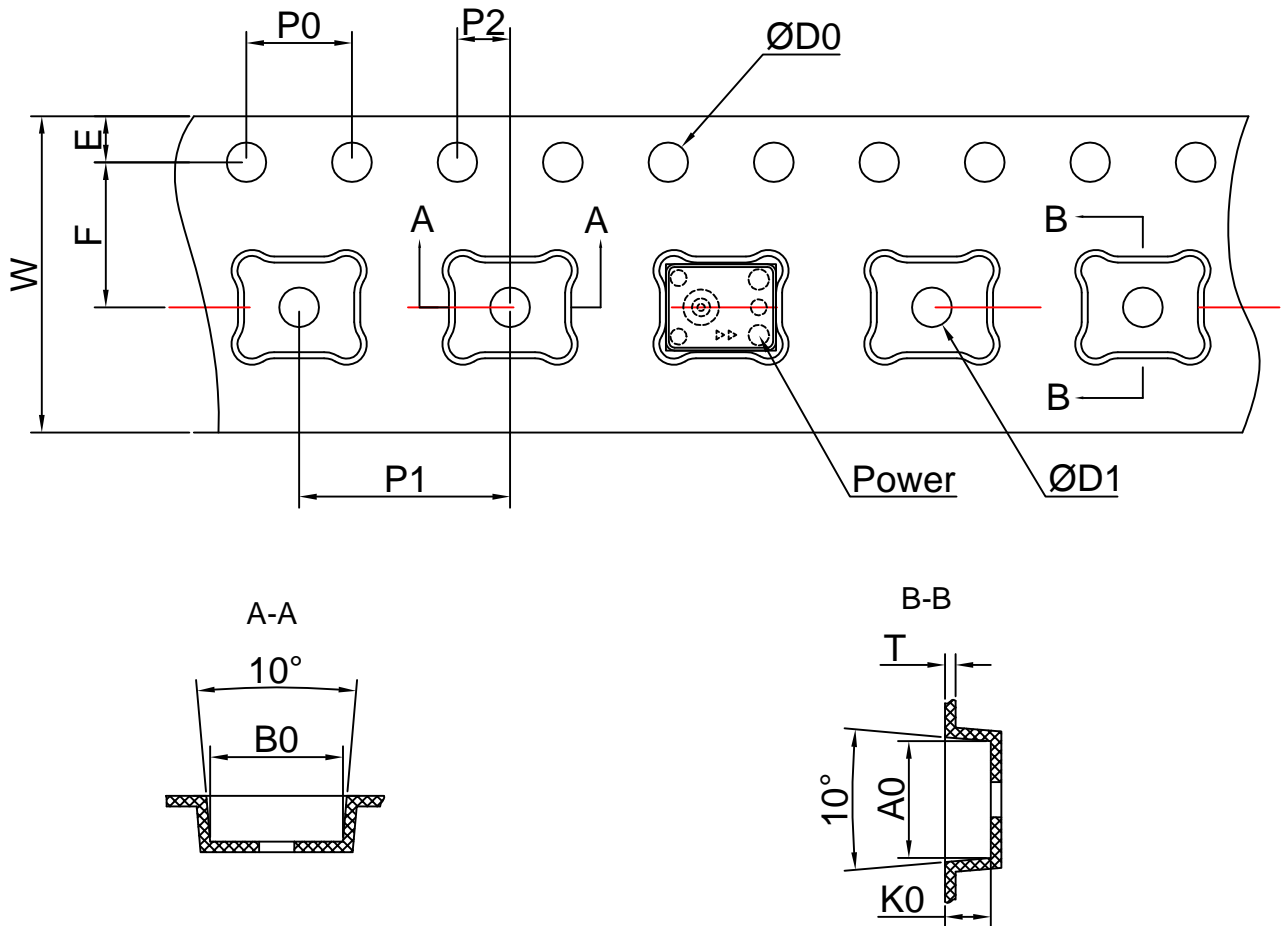

The Dimensions as Follows:

ITEM	W	E	F	ØD0	ØD1
DIM(mm)	12.0±0.30	1.75±0.10	5.5±0.05	1.50±0.1	1.0 MIN
ITEM	P0	10P0	P1	A0	B0
DIM(mm)	4.00±0.10	40.00±0.20	8.00±0.10	3.28±0.10	4.03±0.10
ITEM	K0	P2	T		
DIM(mm)	1.30±0.10	2.00±0.05	0.30±0.05		

9.2 Reel Dimension

7" reel for sample stage

13" reel will be provided for the mass production stage

The following is 13" reel dimensions (unit:mm)

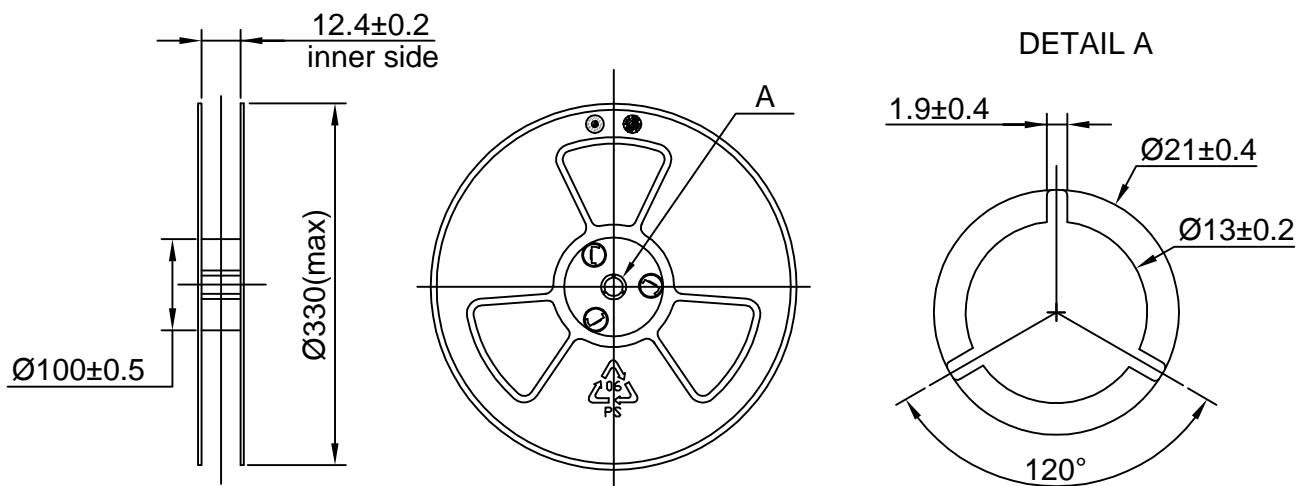

9.3 The Content of Box(13" reel)

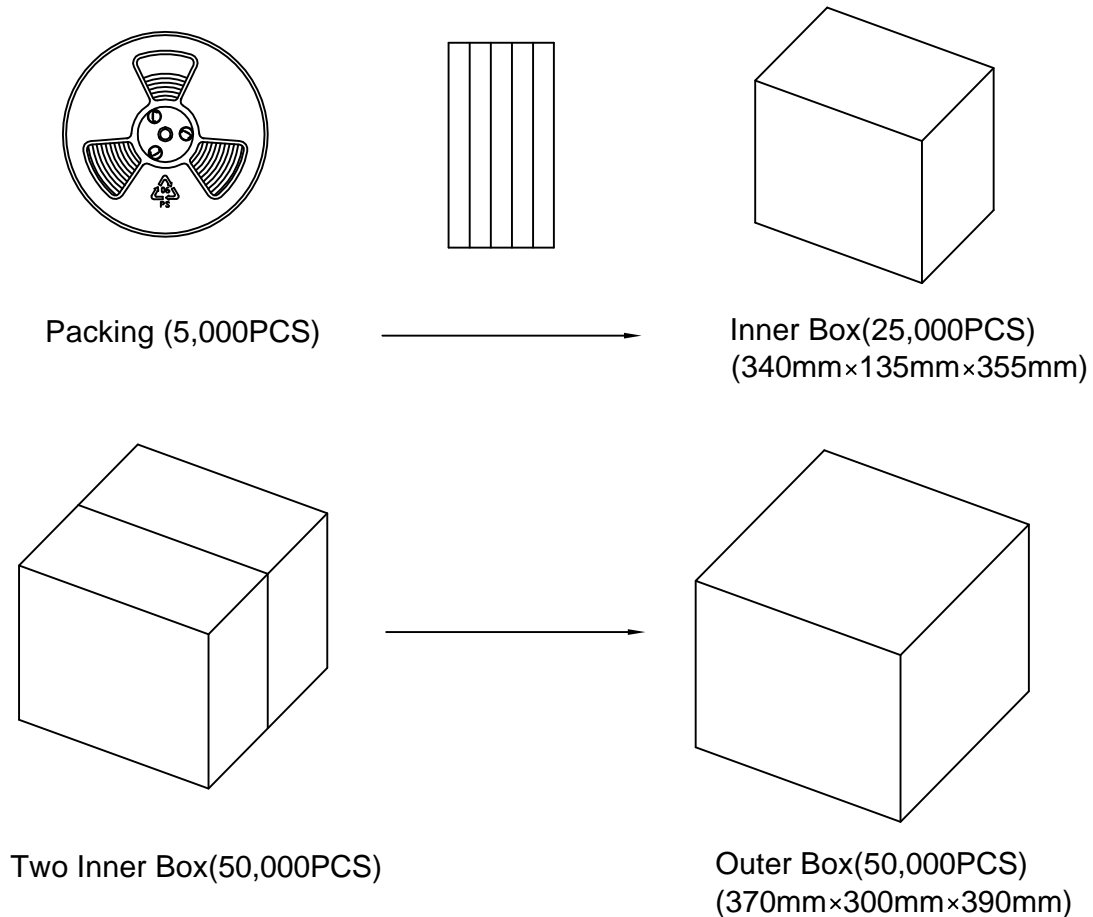

9.4 Packing Explain

9.4.1 The Label Content of the Reel

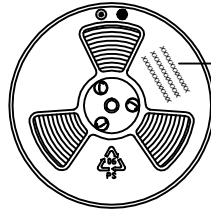

The Content Includes:
Product type, Lot, Customer P/N;
and other essential information such as
Quantity, Date etc.

9.4.2 The RoHS Label

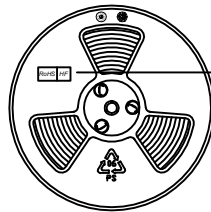

RoHS
Compliance Mark &
Halogen Free

10 Storage and Transportation

- 10.1 Keep MEMS MIC in warehouse with less than 75% humidity and without sudden temperature change, acid air, any other harmful air or strong magnetic field. Recommend storage period no more than 1 year and floor life(out of bag) at factory no more than 4 weeks.
- 10.2 The MEMS MIC with normal pack can be transported by ordinary conveyances. Please protect products against moist, shock, sunburn and pressure during transportation.
- 10.3 Storage Temperature Range : $-40^{\circ}\text{C} \sim +70^{\circ}\text{C}$ (Microphone units with package)
- 10.4 Operating Temperature Range : $-40^{\circ}\text{C} \sim +100^{\circ}\text{C}$

11 Land Pattern Recommendation

11.1 The Pattern of MIC Pad(Unit:mm)

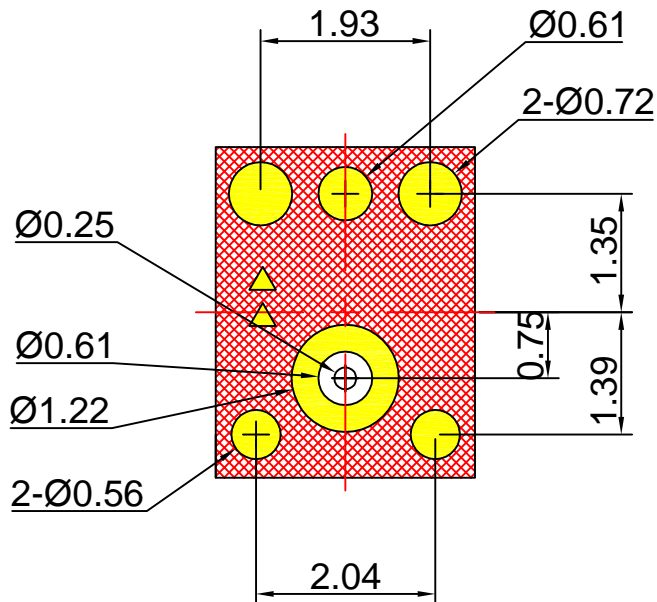

11.2 Recommended Soldering Surface Land Pattern(Unit:mm)

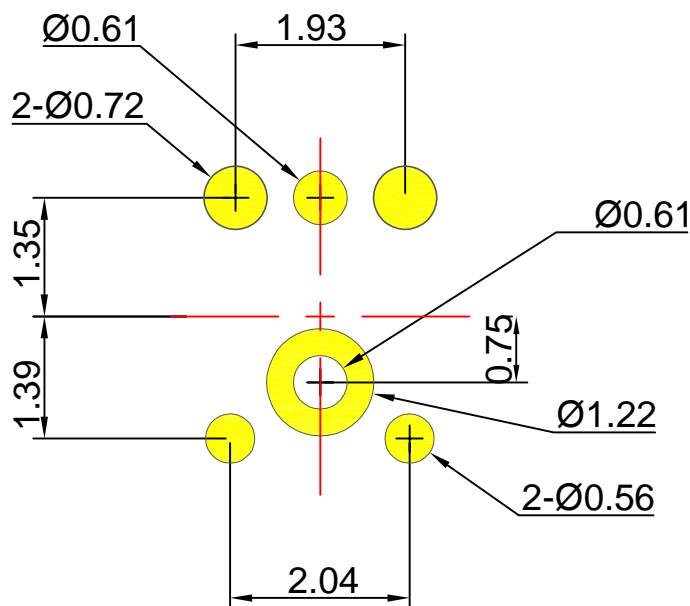

12 Soldering Recommendation

12.1 Soldering Machine Condition

Temperature Control	8 zones
Heater Type	Hot Air
Solder Type	Lead-free

12.2 The Drawing and Dimension of Nozzle

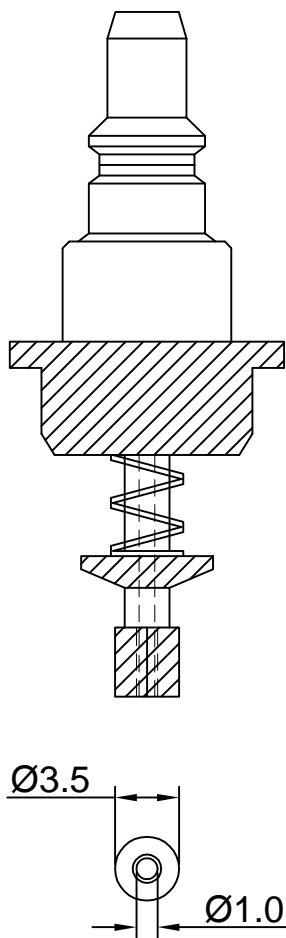

Inside Diameter: $\text{Ø}1.0\text{mm}$;
 Acoustic Port: $\text{Ø}0.25\text{mm}$;
 Vacuum Degree of Nozzle: $-80\sim-90\text{kPa}$;

Please don't vacuum over the acoustic port directly.
 Please don't blow the acoustic port directly.

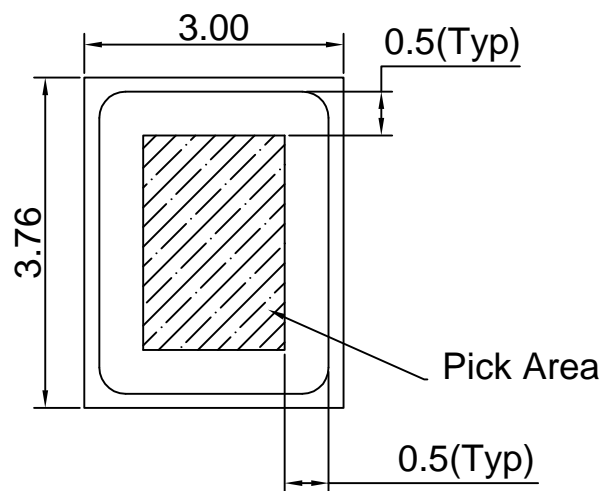

12.3 Reflow Profile

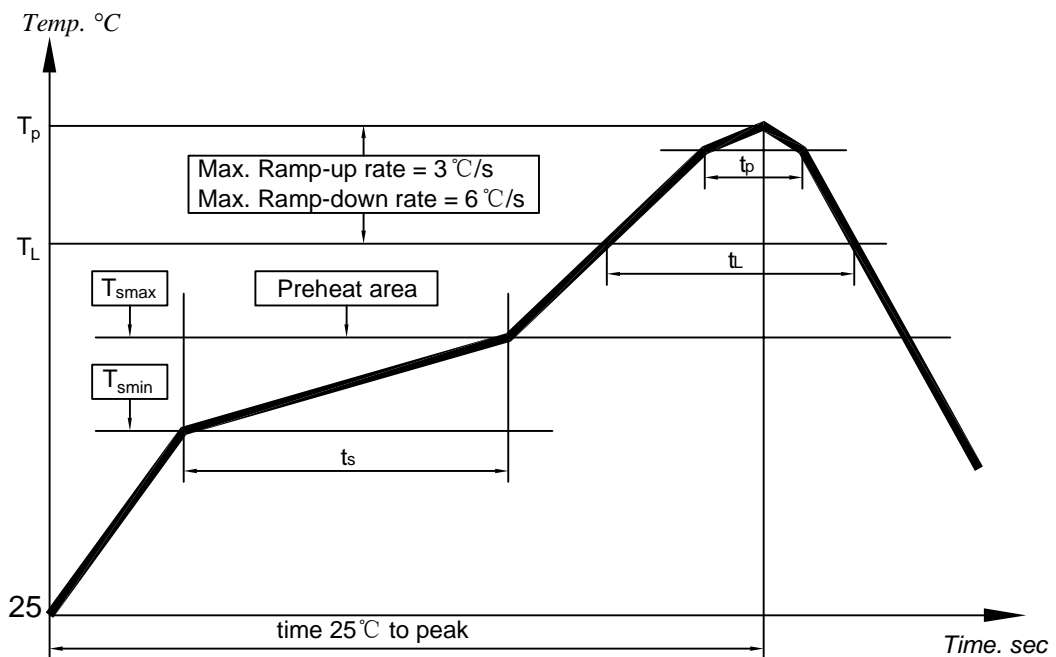

Key Features of The Profile:

Average Ramp-up rate(T_{smax} to T_p)	3°C/s max.
Preheat : Temperature Min(T_{smin}) Temperature Max(T_{smax}) Time(T_{smin} to T_{smax})(t_s)	150°C 200°C 60~180s
Time maintained above : Temperature(T_L) Time(t_L)	217°C 60~150s
Peak Temperature(T_p)	260°C
Time within 5°C of actual Peak Temperature(t_p) :	30~40s
Ramp-down rate(T_p to T_{smax})	6°C/s max
Time 25°C to Peak Temperature	8min max

When MEMS MIC is soldered on PCB, the reflow profile is set according to solder paste and the thickness of PCB etc.

13 Cautions When Using MEMS MIC

13.1 Board Wash Restrictions

It is very important not to wash the PCBA after reflow process, otherwise this could damage the microphone.

13.2 Nozzle Restrictions

It is very important not to pull a nozzle over the port hole of the microphone. otherwise this could damage the microphone.

13.3 Ultrasonic Restrictions

It is very important not to use ultrasonic process. otherwise this could damage the microphone.

14 Output Inspection Standard

Output inspection standard is executed according to <<ISO2859-1:1999>>.