

REV.	MODIFICATION.	DATE	DRN
04	CO2010058	18/02/08	SF
05	CO2010064	19/02/08	SF
06	CO2010181	11/04/08	SF

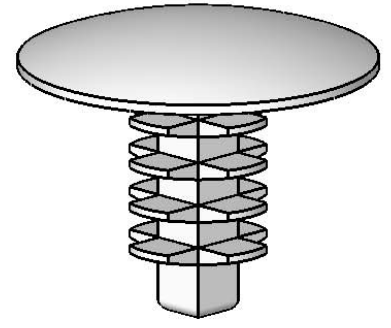
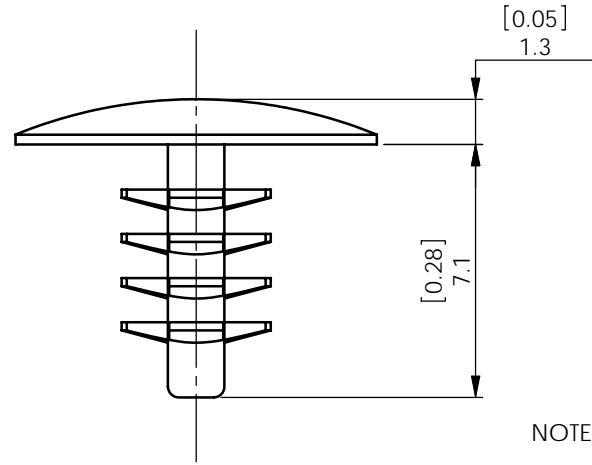
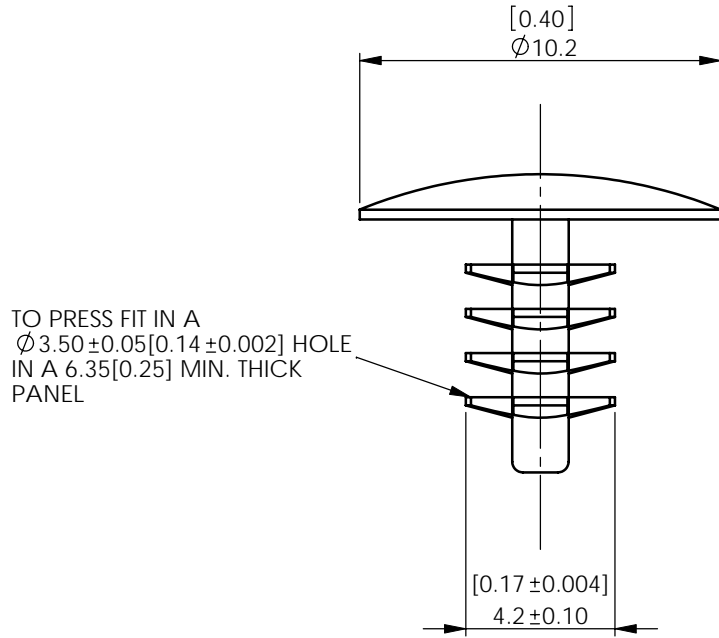

NOTE
 PARTS AVAILABLE IN BLACK, ADD "BK" TO END OF
 PART NUMBER:
 PFP-7-01BK

INFORMATION CONTAINED IN THIS DOCUMENT IS CONFIDENTIAL TO
 RICHCO INTERNATIONAL Co. Ltd. AND MAY NOT BE DISCLOSED OR
 REPRODUCED IN WHOLE OR PART WITHOUT THEIR WRITTEN CONSENT.

	ALL DIMENSIONS IN mm GENERAL TOLERANCES ± 0.25 UNLESS OTHERWISE STATED 1 DECIMAL PLACE ± 0.25 2 DECIMAL PLACES ± 0.10 ANGULAR $\pm 1^\circ$	THIRD ANGLE

MATERIAL: SEE TABLE			COLOUR: NATURAL		
DESCRIPTION: PRESS FIT PIN			PART No: SEE TABLE		
DRG No: 375-0004		NPR No: N/A		Mass:(g) 0.9	SHEET SIZE A4
DRN SF	DATE 18/02/08	CHKD TC	DATE 18/02/08	SCALE NTS	SHEET No. 1 OF 1

PART NUMBER	MATERIAL
PFP-7-01	NYLON 6/6 UL 94 V2(RMS-01)
PFP-7-19	NYLON 6/6 UL 94 V0 (RMS-19)