

50-75-100QBR_3 Series

50W/75W/100W - Single Output DC-DC Converter - Wide Input - Isolated & Regulated

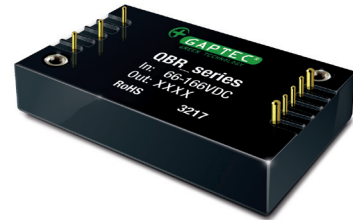

DC-DC Converter 50W / 75W / 100W

- ⊕ Wide range of input voltage: 66-160V
- ⊕ Efficiency up to 92%
- ⊕ Low no-load power
- ⊕ Isolation voltage 3000VDC
- ⊕ Operating temperature range: -40°C ~ +100°C
- ⊕ Input under-voltage protection, output over-voltage, over-current, over-temperature protection
- ⊕ International standard: 1/4 brick
- ⊕ Short circuit protection (SCP)
- ⊕ Meets requirements of UL60950 and railway standard EN50155

The 50-75-100QBR_3 series is a high performance product designed for the field of railway applications. Output power contains 50W/75W/100W, no min. load requirement, wide input voltage 66-160VDC, which allows the base plate temperature up to 100°C.

Further product features include input under-voltage protection, output over-voltage protection, short circuit protection, over temperature protection, remote control and compensated, output voltage regulation functions.

Meets the EN50155 railway standard and UL/EN60950 safety standards. Widely used in the railway system and associated equipment.



Common specifications

Short circuit protection:	Continuous
Temperature rise at full load:	25°C TYP
Cooling:	Natural convection or forced convection
Operation temperature range:	-40°C ~ +100°C
Over-temperature Protection:	Base-Plate Temperature 115°C MAX
Thermal resistance:	<ul style="list-style-type: none"> • xxxQBR_110S3: <ul style="list-style-type: none"> - Natural convection 10.7°C/W MIN - 200LFM convection 6.0°C/W MIN - 400LFM convection 5.0°C/W MIN - 1000LFM convection 4.0°C/W MIN • xxxQBR_110S3H: <ul style="list-style-type: none"> - Natural convection 5.1°C/W MIN - 200LFM convection 2.8°C/W MIN - 400LFM convection 2.2°C/W MIN - 1000LFM convection 1.8°C/W MIN
Storage temperature range:	-55°C ~ +125°C
Lead temperature:	300°C MAX, 1.5mm from case for 10 sec
Storage humidity range:	Non-condensing < 95%RH
Casing material:	Black flame-retardant and heat-resistant plastic (UL94-V0)
Switching frequency:	PFM mode 220KHz TYP
MTBF:	MIL-HDBK-217F @ 25°C 500 Khours MIN
Weight:	46g (no keatsink) 76g (with heatsink)
Cooling test:	EN60068-2-1
Dry heat:	EN60068-2-2
Damp heat:	EN60068-2-30
Shock and vibration test:	IEC/EN61373

Example:

50QBR_110S3
 50 = 50 Watt; QBR = Quarter Brick; 110 = Nominal Output Voltage;
 S = Single Output; 3 = 3000 VDC Insulation

Input specifications

Item	Test condition	Min	Typ	Max	Units
Input current (No load/full load)	Nominal input				mA
	• 50QBR_24S3		5/988		mA
	• 75QBR_24S3		5/741		mA
	• 100QBR_24S3		5/494		mA
Surge voltage	(1sec max)	-0.7		180	VDC
Reflected ripple current	Nominal input		50		mA
Start-up Threshold Voltage				66	VDC
Under-voltage Shutdown Voltage			55		VDC
Start-up Time			25		ms
Filter	PI filter				
Ctrl*	<ul style="list-style-type: none"> • Module switch on • Module switch off • Input current when switched off 			<ul style="list-style-type: none"> • Ctrl psuspended or connected to TTL high level (3.5-12VDC) • Ctrl connected to -Vin or low level (0-1.2VDC) • 2mA (TYP) 	

* The voltage of ctrl pin is relative to input pin - Vin.

Isolation specifications

Item	Test condition	Min	Typ	Max	Units
Insulation voltage	Input-output, with the test time of 1 minute and the leak current less than 1mA				
		• Input-output	3000		VDC
		• Input-case	1500		VDC
		• Output-case	1500		VDC
Insulation resistance	Test at 500VDC	1000			MΩ
Isolation Capacitance	Input/output, 100KHz/0.1V		2200		pF

50-75-100QBR75_3 Series

50W/75W/100W - Single Output DC-DC Converter - Wide Input - Isolated & Regulated

Output specifications					
Item	Test condition	Min	Typ	Max	Units
Output power		0.1		1	W
Line regulation	Full load, input voltage low to high			±0.3	%
Load regulation	Nominal input, 10%-100% load				%
Output voltage accuracy	Nominal input, 10%-100% load			±2	%
Transient Recovery Time	25% load step change		300	500	µs
Transient Response Deviation	25% load step change		±3	±5	%
Temperature drift	100% full load			±0.03	%/°C
Ripple & Noise*	20MHz Bandwidth		100	300	mVp-p
Output voltage Regulated range (Trim)		-10		10	%
Output voltage remote Compensation (Sense)	Input voltage range			5	%
Output Over-voltage Protection	Input voltage range	110		140	%Vo
Output Over-current Protection	Input voltage range	110	130	180	%Io

* The measuring method of ripple and noise, please refer to Design reference, 1. Ripple & Noise

Note:

1. Recommended used in more than 5% load, if the load is lower than 5%, then the ripple index of the product may exceed the specification, but does not affect the reliability of the product;
2. The max capacitive load should be tested within the input voltage range and under full load conditions;
3. Recommends that customers plus silicone film or thermal grease between the module and the heatsink, In order to ensure good heat dissipation;
4. Unless otherwise specified, data in this datasheet should be tested under the conditions of Ta = 25°C, humidity < 75% when inputting nominal voltage and outputting rated load;
5. All index testing methods in this datasheet are based on our company's corporate standards;
6. The performance indexes of the product models listed in this datasheet are as above, but some indexes of non-standard model products will exceed the abovementioned requirements, and please directly contact our technicians for specific information;
7. We can provide product customization service;
8. Specifications of this product are subject to changes without prior notice.

EMC specifications					
EMI	CE	CISPR22/EN55022	150KHz-30MHz	CLASS B	(see EMC solution module rec. circuit)
EMI	RE	CISPR22/EN55022	30MHz-1GHz	CLASS B*	(see EMC solution module rec. circuit)
EMS	ESD	IEC/EN61000-4-2 GB/T17626.2	Contact ±6KV; Air ±8KV		perf. Criteria B
EMS	Radiation Immunity	IEC/EN61000-4-3 GB/T17626.3	10V/m		perf. Criteria A
EMS	Conducted disturbance Immunity	IEC/EN61000-4-6 GB/T17626.6	10Vr.m.s		perf. Criteria A
EMS	EFT	IEC/EN61000-4-4 GB/T17626.4	±2KV (5KHz, 100KHz)	(see EMC solution module rec. circuit)	perf. Criteria B
EMS	Surge Immunity	IEC/EN61000-4-5 GB/T17626.5 EN50155	±2KV (1.2µs/50µs 2Ω) ±4KV (1.2µs/50µs 12Ω) ±1.8KV (5/50µs 5Ω)	(see EMC solution module rec. circuit) (see EMC solution module rec. circuit) (see EMC solution module rec. circuit)	perf. Criteria B perf. Criteria B perf. Criteria B
EMS	Immunities of short interruption	EN50155	100%-0%, 10ms	(see EMC solution module rec. circuit)	perf. Criteria B

Part Number	Input Voltage [VDC]		Output Voltage [VDC]	Current [mA, max]	Efficiency [%, typ]	Capacitive load [µF, max]
	Nominal (range)	Max.*				
50QBR_11024S3	110 (66-160)	170	24	2083	92	3000
75QBR_11024S3	110 (66-160)	170	24	3125	92	3000
100QBR_11024S3	110 (66-160)	170	24	4167	92	3000

Note:

Add suffix „H“ for heatsink.

* Absolute maximum rating without damage on the converter, but it isn't recommended.

50-75-100QBR75_3 Series

50W/75W/100W - Single Output DC-DC Converter - Wide Input - Isolated & Regulated

Efficiency curves

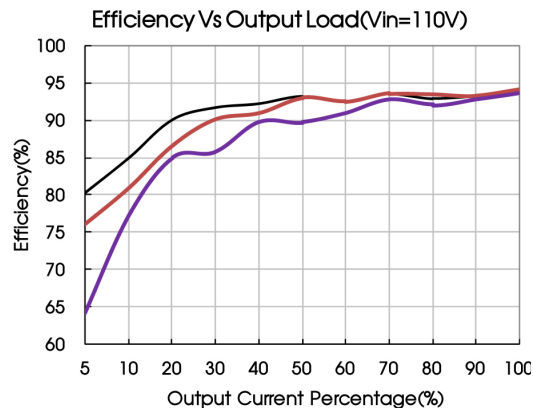
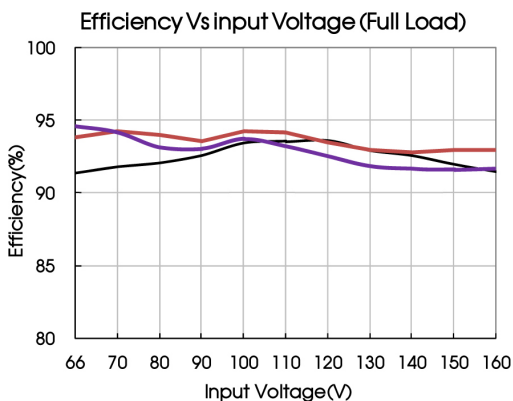

Thermal curves

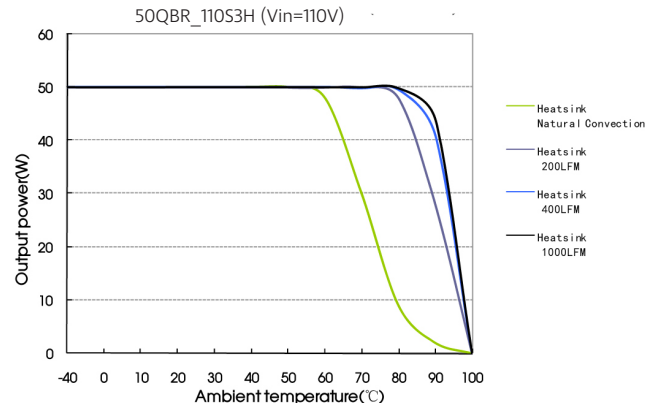
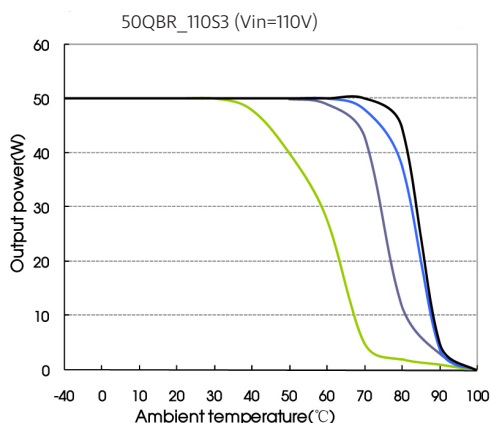
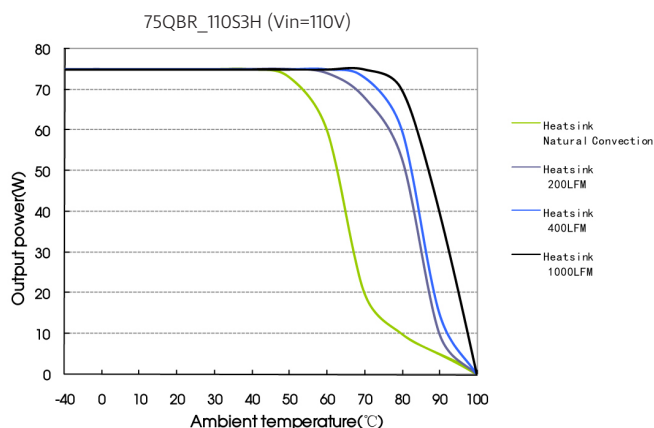
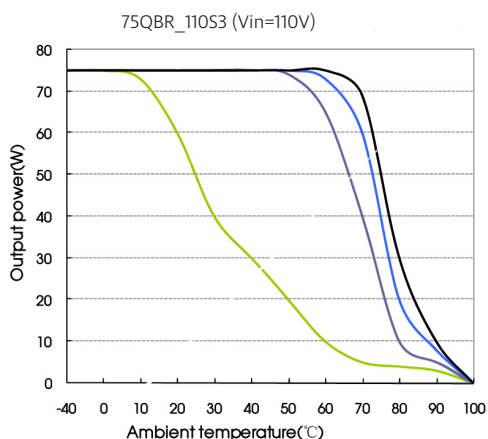
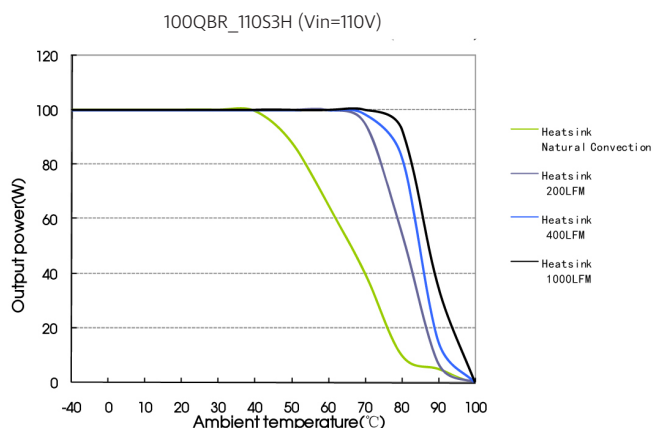
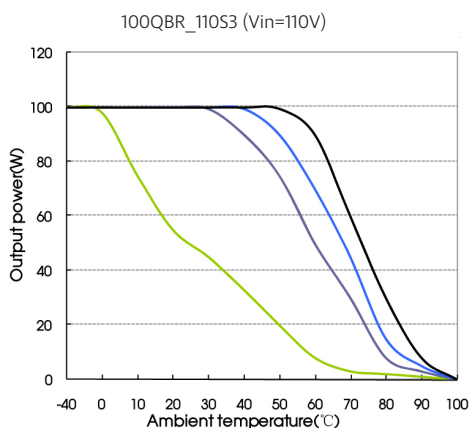

50-75-100QBR75_3 Series

50W/75W/100W - Single Output DC-DC Converter - Wide Input - Isolated & Regulated

Sense of application and precautions

1. When Remote Sense is not used

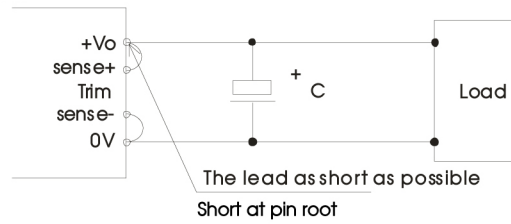

- Notes:
- 1) When remote sense is not used, make sure +Vo and Sense + are shorted, and that 0V and Sense- are shorted as well;
 - 2) Keep the patterns between +Vo and Sense + and 0V and Sense- as short as possible. Avoid a looping pattern. If noise enters the loop, the operation of the power module will become unstable.

2. When Remote Sense is not used

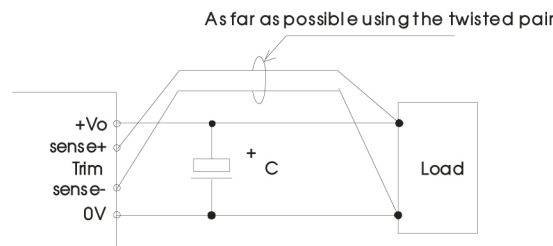

- Notes:
1. Using remote sense with long wires may cause output voltage to become unstable. Consult us if long sensing wiring is necessary.
 2. Sense patterns or wires should be as short as possible. If wires are used, use either twisted-pair or shielded wires.
 3. Please Use wide PCB trace or a thick wires between the power supply module and the load, the line voltage drop should be kept less than 0.3V. Make sure the power supply module's output voltage remains within the specified range.
 4. The impedance of wires may cause the output the voltage oscillation or have a greater ripple, please do adequate assessments before using.

Design reference

1. Ripple & noise

All the 100QBR_24S3 series have been tested according to the following recommended test circuit before leaving the factory.

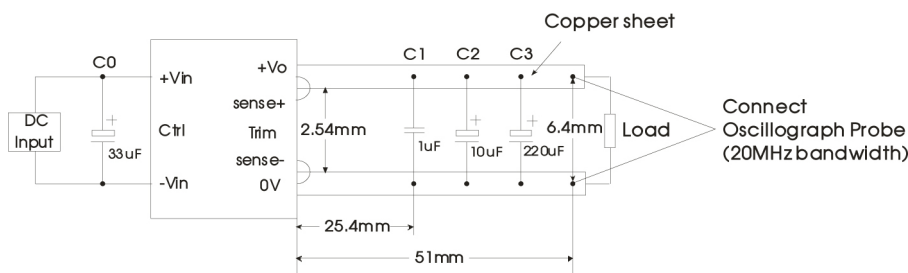

2. Typical application

If don't use our company's EMC models, please make sure the input of at least 33uF electrolytic capacitor in parallel to suppress the input terminal may produce surge voltage.

If it is required to further reduce input and output ripple, properly increase the input & output of additional capacitors Cin and Cout or select capacitors of low equivalent impedance provided that the capacitance is no larger than the max. capacitive load of the product.



Capacitive Parameter	Cout(μF)	Cin(μF)
Output Voltage		
24V	220	100

50-75-100QBR75_3 Series

50W/75W/100W - Single Output DC-DC Converter - Wide Input - Isolated & Regulated

Design reference

3. REMC solution-module recommended circuit

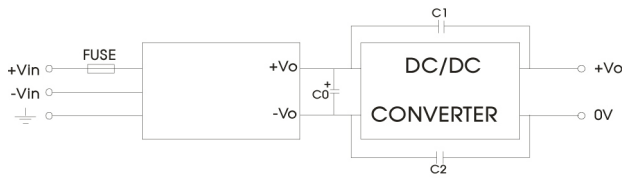

C0	82uF/200V electrolytic capacitor
C1, C2	2200pF/400VAC capacitor
FC-xxxD	recommended to use GAPTEC's FC-CX3D
FUSE	Due to the difference of the power module input current, the fuse of the recommended values, please refer to the Technical Manual for the powermodule.

4. Thermal design

The maximum operating temperature of base-plate TB is 100°C, as long as the user's thermal system keeps TB <100°C, the converter can deliver its full rated power. A power derating curve can be calculated for any heatsink that is attached to the base-plate of the converter. It is only necessary to determine the thermal resistance, Rth(B-A), of the chosen heatsink between the base-plate and then ambient air for a given air-flow rate. This information is usually available from the heatsink vendor. The following formula can be used to determine the maximum power the converter can dissipate for a given thermal condition if its base-plate is to be no higher than 100 °C.

$$P_{diss}^{max} = \frac{100^{\circ}C - T_A}{R_{th(B-A)}} \quad (T_A \text{ is ambient temperature})$$

The maximum load operating power of power supply module at a certain ambient temperature can be calculated by the power dissipation, Formula is as follows:

$$P_{O_{max}} = \frac{P_{diss}^{max}}{\left(\frac{1}{\eta} - 1\right)} \quad (\eta \text{ is converter efficiency})$$

5. Application of Trim and calculation of Trim resistance

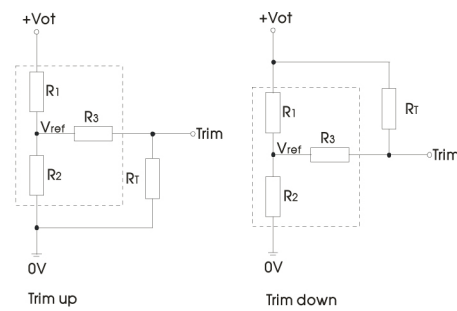

Applied circuits of Trim (Part in broken line is the interior of models)

Calculation formula of trim resistance:

$$\begin{aligned} \text{up: } R_T &= \frac{\alpha R_2}{R_2 - \alpha} - R_3 & \alpha &= \frac{V_{ref}}{V_o' - V_{ref}} \cdot R_1 \\ \text{down: } R_T &= \frac{\alpha R_1}{R_1 - \alpha} - R_3 & \alpha &= \frac{V_o' - V_{ref}}{V_{ref}} \cdot R_2 \end{aligned}$$

Note: Value for R1, R2, R3, and Vref refer to the above table
 1. RT: Resistance of Trim.
 a: User-defined parameter, no actual meanings.
 Vo': The trim up/down voltage.

6. The product does not support in parallel and hot-plug use

50-75-100QBR75_3 Series

50W/75W/100W - Single Output DC-DC Converter - Wide Input - Isolated & Regulated

Mechanical dimensions and recommended layout (without heatsink)

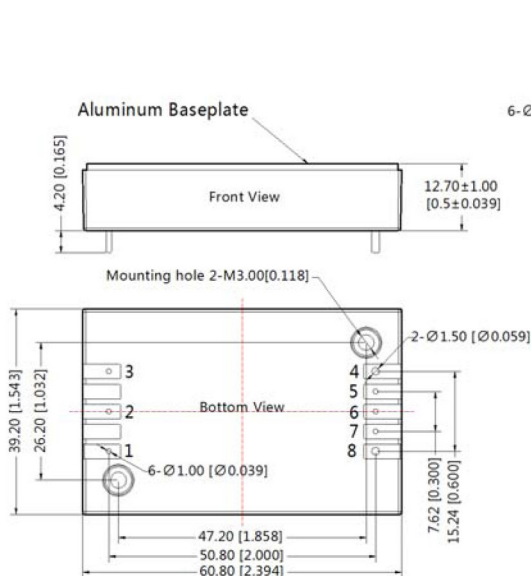

Note:
 Unit:mm[inch]
 Pin1,2,3,5,6,7's diameter:1.00[0.039]
 Pin4,8's diameter:1.50[0.059]
 Pin diameter tolerances:±0.10[±0.004]
 General tolerances:±0.50[±0.020]
 Mounting hole screwing torque: Max 0.4 N·m

THIRD ANGLE PROJECTION

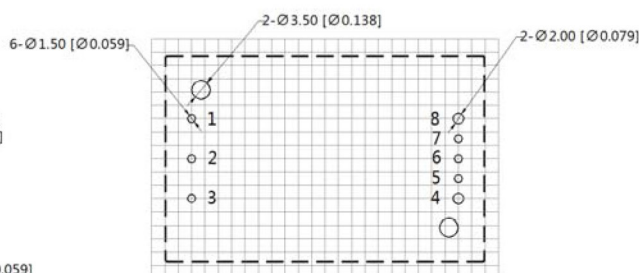

Note:Grid 2.54*2.54mm

Pin-Out			
Pin	Function	Pin	Function
1	+Vin	5	Sense-
2	Ctrl	6	Trim
3	-Vin	7	Sense+
4	0V	8	+Vo

Mechanical dimensions and recommended layout (with heatsink)

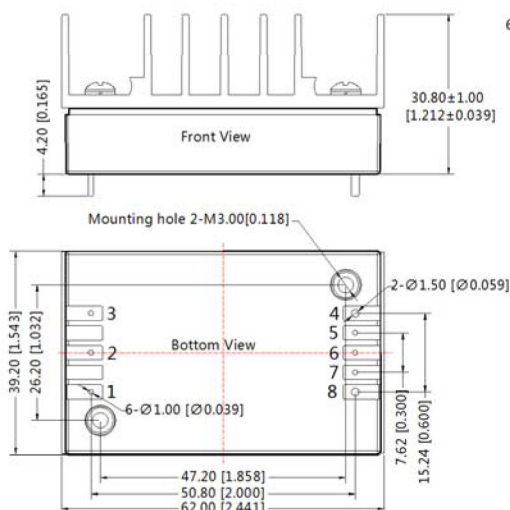

Note:
 Unit:mm[inch]
 Pin1,2,3,5,6,7's diameter:1.00[0.039]
 Pin4,8's diameter:1.50[0.059]
 Pin diameter tolerances:±0.10[±0.004]
 General tolerances:±0.50[±0.020]
 Mounting hole screwing torque: Max 0.4 N·m

THIRD ANGLE PROJECTION

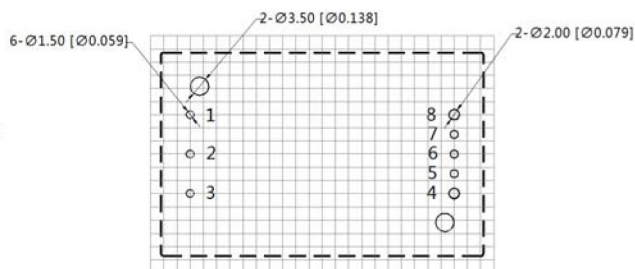

Note:Grid 2.54*2.54mm

Pin-Out			
Pin	Function	Pin	Function
1	+Vin	5	Sense-
2	Ctrl	6	Trim
3	-Vin	7	Sense+
4	0V	8	+Vo