

910/911 Series Lampholders for 900/901 Cartridge Lamps

Overview

The 910 Series relampable lampholders accept any 900 Series cartridge lamp. These lampholders are of ruggedized construction and are supplied with mounting hardware.

Approvals

UL Recognized and CSA Certified

Specifications

Housing and Knurled Ring Nut: Aluminum. Black anodized finish standard. Clear anodized finish optional. Other finishes available on special request. A mounting wrench, #097013, is available for tightening the knurled ring nuts.

Hex Nut: Brass; nickel finish.

Internal Tooth Lockwasher: Nickel-plated finish.

Terminal Insulator: High dielectric composition.

Terminals: Solder cup, turret pin or solder lug.

Socket: Brass. Bright nickel-plated.

Lens Cap: Heat resistant, high strength polycarbonate.

Lens Marking: Lens style 21 maybe be stamped.

Contact factory.

910 Series Maximum Rating: 3 Watts, 125 Volts.

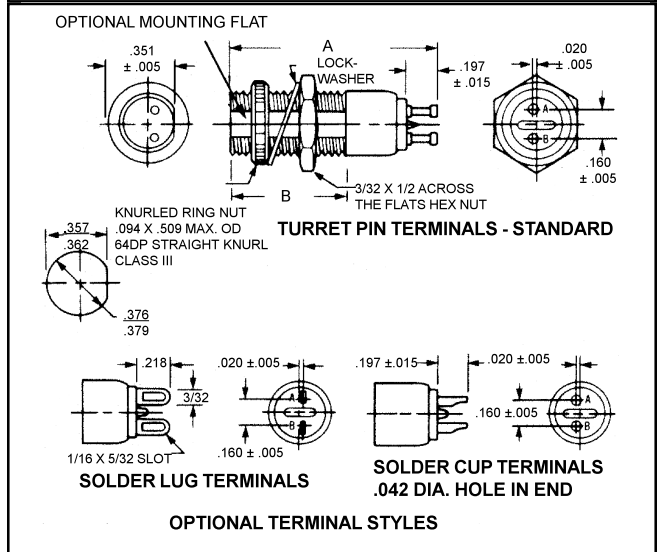

Lampholder Body	Dimension in Inches	
	A	B
910	1.203 Max.	9/16
911	1.281 Max.	5/8

ORDERING INFORMATION:

EXAMPLE: 9 1 0 2 0 1 X 21 1 BT

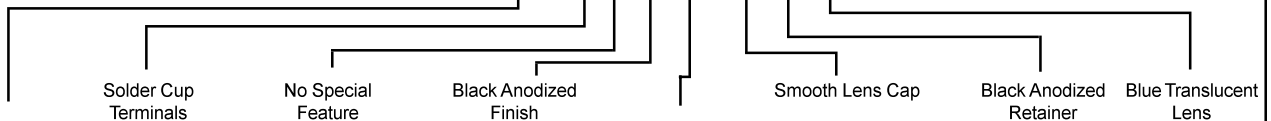

Series Number	Cartridge Lampholders				Lens Caps and Collars		
	Termination	Features	Finish	Resistor	Lens Style	Retainer Finish	Lens Color
910	2 Solder Cup	0 None	1 Black Anodized - Standard	X None Required	21 Smooth Lens	1 Black Anodized	Nondiffusing (Clear)
	4 Solder Lug	1 D Hole Mounting			27 Fluted Lens (Nondiffusing Colors Only)		AN Amber BN ² Blue CN Colorless GN ² Green RN Red WN White (Cloudy) YN Yellow
					23 ¹ Collar	2 Clear (Silver) Anodized	
					24 ¹ Collar		

¹ No lens color specified. Use XX in lens color slot. Example: 901-201X-231XX.
² Use with blue or green neon lamps in the 911 series. Not for use with neon cartridge lamps in the 910 series.
³ Not recommended for use with neon cartridge lamps.