

Main

Range of product	Modicon Power Supply
Product or component type	Power supply
Power supply type	Regulated switch mode
Nominal input voltage	100...240 V AC phase to phase, terminal(s): L1-L2 100...240 V AC single phase, terminal(s): N-L1 120...250 V DC
Input voltage limits	85...264 V AC
Rated power in W	7 W
Output voltage	24 V DC
Power supply output current	0.3 A



Complementary

Input protection type	Integrated fuse (not interchangeable)
Inrush current	20 A
Power factor	0.5 at 24 V DC
Efficiency	78 %
Output voltage adjustment	22.2...28.8 V adjustable
Power dissipation in W	2 W
Current consumption	0.18 A 240 V AC 0.25 A 100 V AC
Residual ripple	250 mV
Output protection type	Thermal Against short-circuits
Connections - terminals	Screw type terminals: 2 x 0.14...2 x 2.5 mm ² , (AWG 26...AWG 14) for input connection Screw type terminals: 2 x 0.14...2 x 2.5 mm ² , (AWG 26...AWG 14) for output connection
Status LED	1 LED (green)output voltage
Depth	59 mm
Height	100 mm
Width	36 mm
Net weight	0.1 kg

The information provided in this documentation contains general descriptions and/or technical characteristics of the performance of the products contained herein. This documentation is not intended as a substitute for and is not to be used for determining suitability or reliability of these products for specific user applications. It is the duty of any such user or integrator to perform the appropriate and complete risk analysis, evaluation and testing of the products with respect to the relevant specific application or use thereof. Neither Schneider Electric Industries SAS nor any of its affiliates or subsidiaries shall be responsible or liable for misuse of the information contained herein.

Output coupling	Parallel Series
Marking	CE
Mounting support	35 x 7.5 mm symmetrical DIN rail Panel 2 screws, diameter : 4 mm 35 x 15 mm symmetrical DIN rail
Operating position	Vertical

Environment

Standards	UL 508 CSA C22.2 No 60950-1
Product certifications	KC TUV 60950-1 RCM EAC CCSAus CSA 22-2 No 950 CULus 508
Environmental characteristic	EMC conforming to EN 55022 class B EMC conforming to EN 61000-6-3 EMC conforming to EN/IEC 61000-6-2 EMC conforming to EN/IEC 61204-3 Safety conforming to EN/IEC 60950-1 Safety conforming to SELV
Operating altitude	2000 m
IP degree of protection	IP20 conforming to EN/IEC 60529
Ambient air temperature for operation	-25...55 °C (without) 55...70 °C (with derating factor)
Ambient air temperature for storage	-40...70 °C
Relative humidity	0...90 % during operation 0...95 % in storage
Dielectric strength	3000 V between input and output

Packing Units

Package 1 Weight	0.134 kg
Package 1 Height	0.500 dm
Package 1 width	0.740 dm
Package 1 Length	1.000 dm

Offer Sustainability

Sustainable offer status	Green Premium product
REACH Regulation	REACH Declaration
EU RoHS Directive	Pro-active compliance (Product out of EU RoHS legal scope) EU RoHS Declaration
Mercury free	Yes
RoHS exemption information	Yes
China RoHS Regulation	China RoHS declaration
Environmental Disclosure	Product Environmental Profile
Circularity Profile	End of Life Information
PVC free	Yes

Contractual warranty

Warranty	18 months
----------	-----------

Regulated Switch Mode Power Supplies

Dimensions

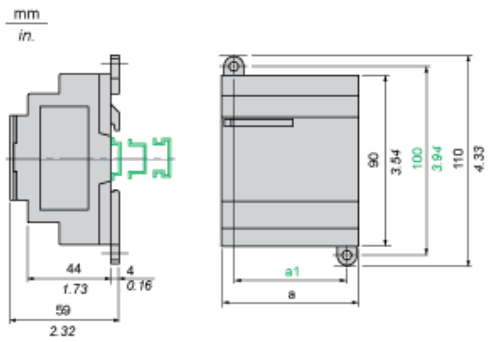

	a in mm	a in in.	a1 in mm	a1 in in.
ABL8MEM05040	54	2.12	42	1.65
ABL8MEM12020	54	2.12	42	1.65
ABL8MEM24003	36	1.41	24	0.94
ABL8MEM24006	36	1.41	24	0.94
ABL8MEM24012	54	2.12	42	1.65
ABL7RM24025	74	2.91	60	2.36

Regulated Switch Mode Power Supply

Internal Wiring Diagram

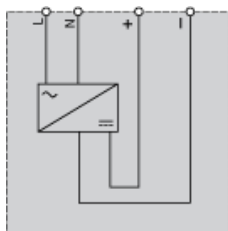

Regulated Switch Mode Power Supplies

Series or Parallel Connection

Series Connection

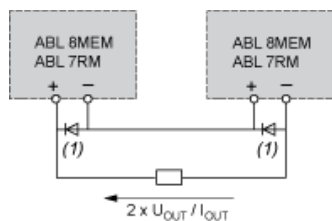

(1) Two Schottky diodes I_{min} = power supply I_n and V_{min} = 50 V

Parallel Connection

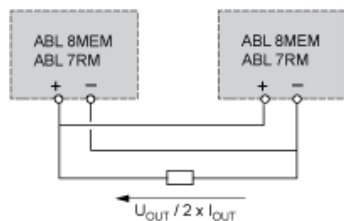

Family	Series	Parallel
ABL 7RM/8MEM	2 products max.	2 products max.

NOTE: Series or parallel connection is only recommended for products with identical references.

Regulated Switch Mode Power Supplies

Derating

The ambient temperature is a determining factor that limits the power an electronic power supply can deliver continuously. If the temperature around the electronic components is too high, their life will be significantly reduced.

The nominal ambient temperature for the Modular range of Phaseo power supplies is 55°C. Above this temperature, derating is necessary up to a maximum temperature of 70°C (except for the ABL7RM24025 model).

The graph below shows the power as a percentage of the nominal power that the power supply can deliver continuously, depending on the ambient temperature.

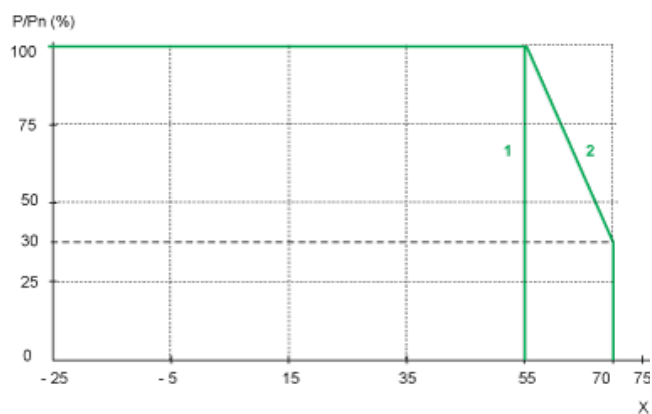

X Maximum operating temperature (°C)

(1) With an ABL7RM24025

(2) With an ABL8MEM.....