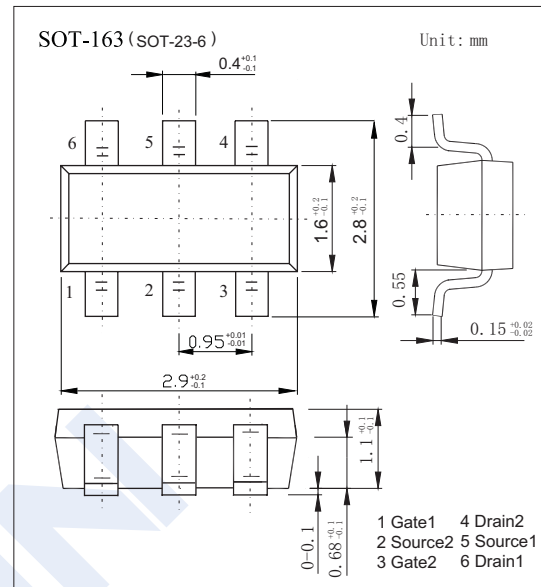
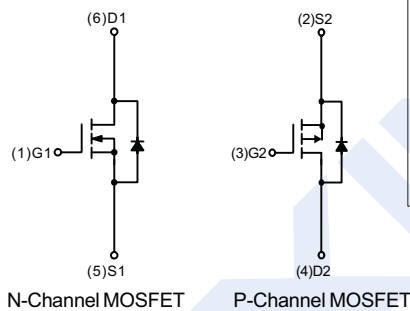

Dual MOSFET (N and P Channel)

APM2701

■ Features

- N-Channel: $V_{DS}=20V$ $I_D=3A$
 $R_{DS(ON)} < 70m\Omega$ (typ.) @ $V_{GS}=4.5V$
 $R_{DS(ON)} < 110m\Omega$ (typ.) @ $V_{GS}=2.5V$
- P-Channel: $V_{DS}=-20V$ $I_D=-1.5A$
 $R_{DS(ON)} < 190m\Omega$ (typ.) @ $V_{GS}=-4.5V$
 $R_{DS(ON)} < 235m\Omega$ (typ.) @ $V_{GS}=-2.5V$
- Super High Dense Cell Design
- Releable and Rugged

■ Absolute Maximum Ratings ($T_a = 25^\circ C$ unless otherwise noted)

Parameter	Symbol	N-Channel	P-Channel	Unit
Drain-Source Voltage	V_{DS}	20	-20	V
Gate-Source Voltage	V_{GS}	± 10	± 10	
Continuous Drain Current	I_D^*	3	-1.5	A
300 μ s Pulsed Drain Current		I_{DM}^*	10	
Diode Continuous Forward Current	I_S^*	1	-1	
Power Dissipation	P_D^*	$T_a=25^\circ C$		W
		$T_a=100^\circ C$		
Thermal Resistance.Junction- to-Ambient	R_{thJA}^*	150		$^\circ C/W$
Junction Temperature	T_J	150		$^\circ C$
Storage Temperature Range	T_{stg}	-55 to 150		

Note: * Surface Mounted on 1 in² pad area, $t \leq 10$ sec.

■ Marking Information

APM2701:	M71X	XXXXX - Date Code
----------	------	-------------------

Dual MOSFET (N and P Channel)

APM2701

■ Electrical Characteristics (Ta = 25°C unless otherwise noted)

Parameter	Symbol	Test Conditions	Type	Min	Typ	Max	Unit
Drain-Source Breakdown Voltage	V _{DSS}	I _D =250 μA, V _{GS} =0V	N-Ch	20			V
		I _D =-250 μA, V _{GS} =0V	P-Ch	-20			
Zero Gate Voltage Drain Current	I _{DSS}	V _{DS} =16V, V _{GS} =0V	N-Ch			1	μA
		V _{DS} =16V, V _{GS} =0V, T _J =85°C				30	
		V _{DS} =-16V, V _{GS} =0V	P-Ch			-1	
		V _{DS} =-16V, V _{GS} =0V, T _J =85°C				-30	
Gate-Body Leakage Current	I _{GSS}	V _{DS} =0V, V _{GS} =±10V	N-Ch			±100	nA
		V _{DS} =0V, V _{GS} =±10V	P-Ch			±100	
Gate Threshold Voltage	V _{GS(th)}	V _{DS} =V _{GS} , I _D =250 μA	N-Ch	0.45		1	V
		V _{DS} =V _{GS} , I _D =-250 μA	P-Ch	-0.45		-1	
Static Drain-Source On-Resistance	R _{DS(on)}	V _{GS} =4.5V, I _D =3A	N-Ch			70	mΩ
		V _{GS} =2.5V, I _D =1.7A				110	
		V _{GS} =-4.5V, I _D =-1.5A	P-Ch			190	
		V _{GS} =-2.5V, I _D =-1A				235	
Input Capacitance	C _{iss}	N-Channel:	N-Ch		270	pF	
	P-Ch			300			
Output Capacitance	C _{oss}	V _{GS} =0V, V _{DS} =10V, f=1MHz	N-Ch		70	pF	
			P-Ch		50		
Reverse Transfer Capacitance	C _{rss}	V _{GS} =0V, V _{DS} =-10V, f=1MHz	N-Ch		50	pF	
			P-Ch		30		
Total Gate Charge	Q _g ^a	N-Channel:	N-Ch		5	6.5	nC
	P-Ch			4	6		
Gate Source Charge	Q _{gs} ^a	V _{GS} =4.5V, V _{DS} =10V, I _D =3A	N-Ch		0.5		nC
			P-Ch		0.6		
Gate Drain Charge	Q _{gd} ^a	V _{GS} =-4.5V, V _{DS} =-10V, I _D =-1.5A	N-Ch		1.6		nC
			P-Ch		1		
Turn-On DelayTime	t _{d(on)}	N-Channel:	N-Ch		6	12	ns
	P-Ch			6	10		
Turn-On Rise Time	t _r	V _{DS} =10V, R _L =10Ω, I _{DS} =1A, V _{GEN} =4.5V, R _G =6Ω	N-Ch		5	10	ns
			P-Ch		8	12	
Turn-Off DelayTime	t _{d(off)}	P-Channel: V _{DS} =-10V, R _L =10Ω, I _{DS} =-1A, V _{GEN} =-4.5V, R _G =6Ω	N-Ch		12	23	ns
			P-Ch		10	15	
Turn-Off Fall Time	t _f	P-Channel: V _{DS} =-10V, R _L =10Ω, I _{DS} =-1A, V _{GEN} =-4.5V, R _G =6Ω	N-Ch		6	12	ns
			P-Ch		5	10	
Diode Forward Voltage	V _{SD} ^b	I _S =0.5A, V _{GS} =0V	N-Ch			1.3	V
		I _S =-0.5A, V _{GS} =0V	P-Ch			-1.3	

Notes: a: Guaranteed by design, not subject to production testing.

b: Pulse test; pulse width ≤ 300μs, duty cycle ≤ 2%.

Dual MOSFET (N and P Channel)

APM2701

■ Typical Characteristics

N-Channel

Power Dissipation

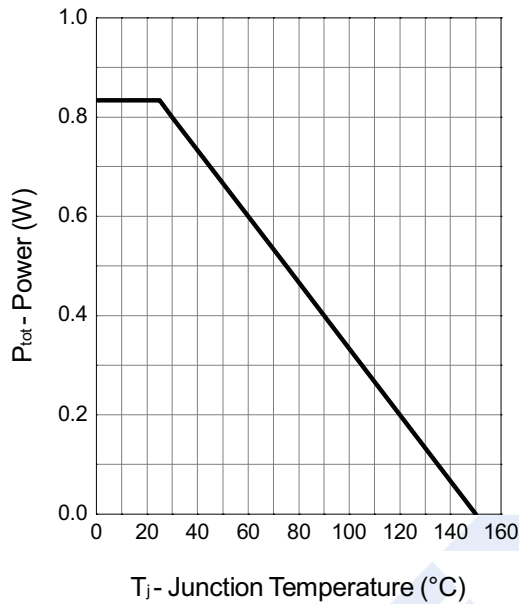

Drain Current

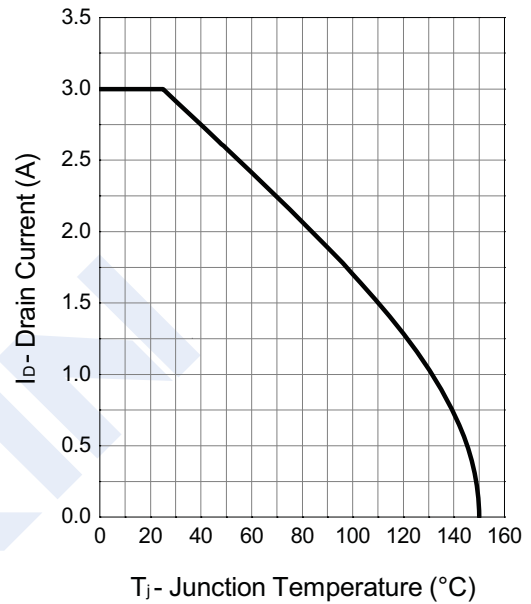

Safe Operation Area

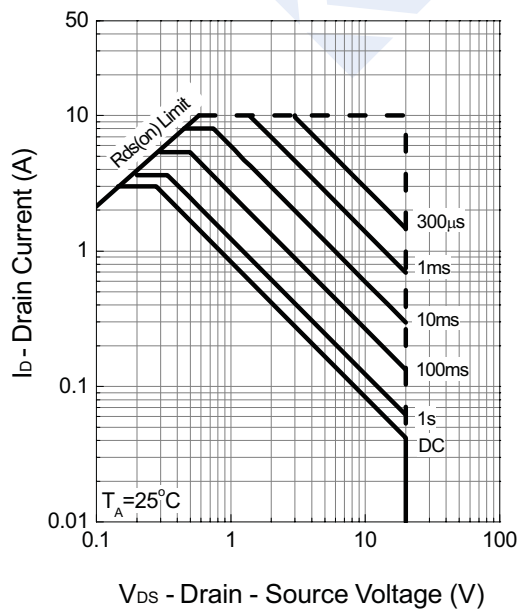

Thermal Transient Impedance

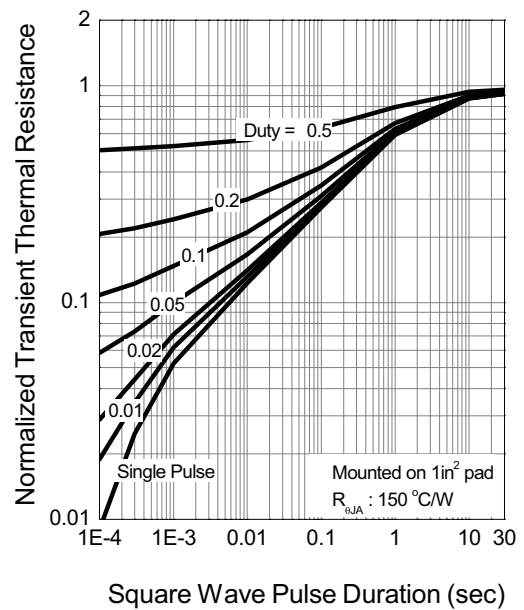

Dual MOSFET (N and P Channel)

APM2701

■ Typical Characteristics (Cont.)

Output Characteristics

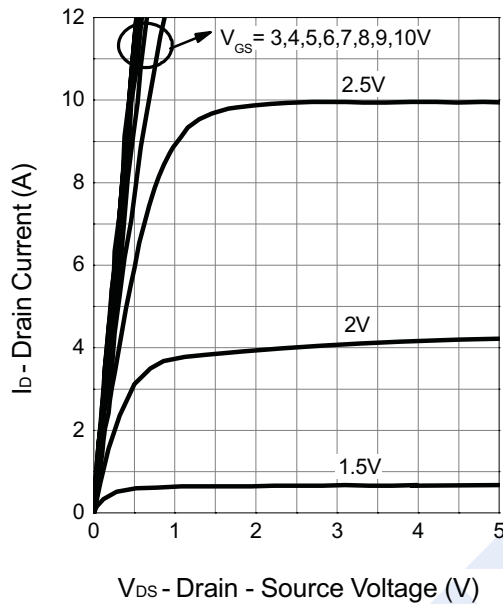

Drain-Source On Resistance

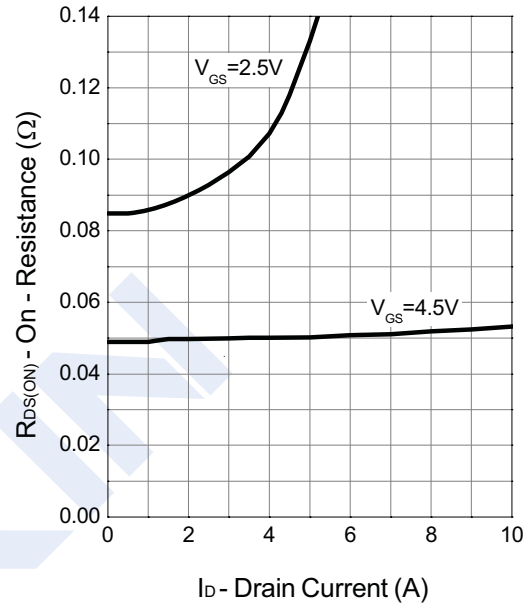

Transfer Characteristics

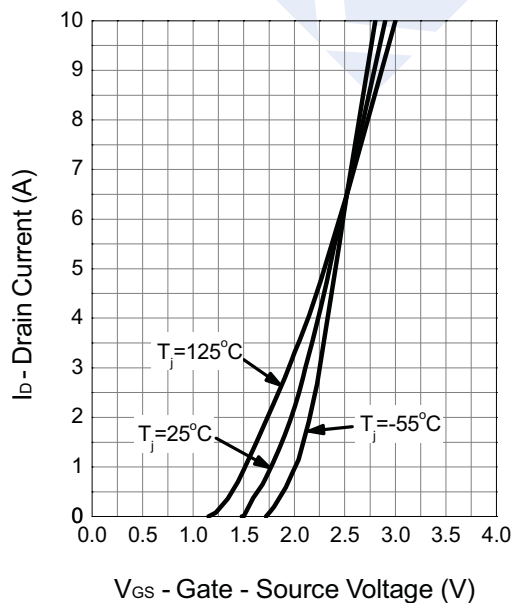

Gate Threshold Voltage

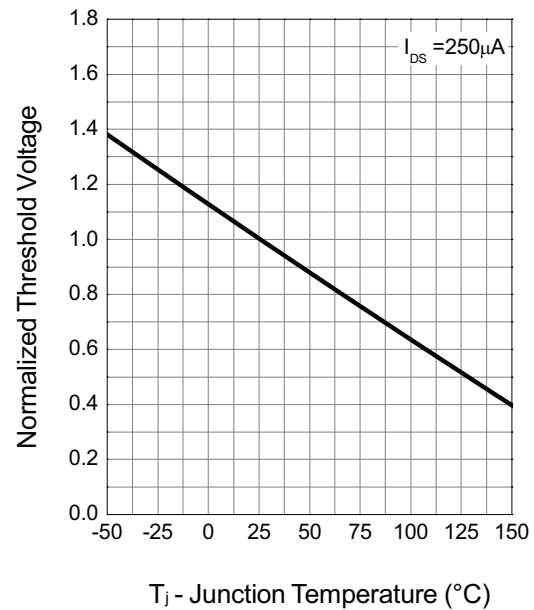

Dual MOSFET (N and P Channel)

APM2701

■ Typical Characteristics (Cont.)

Drain-Source On Resistance

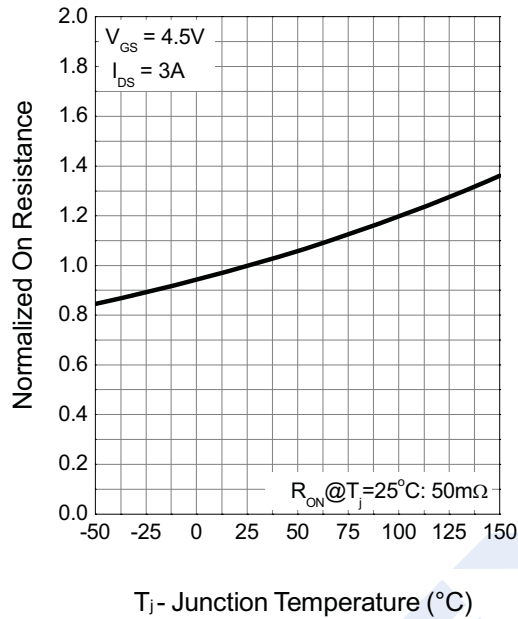

Source-Drain Diode Forward

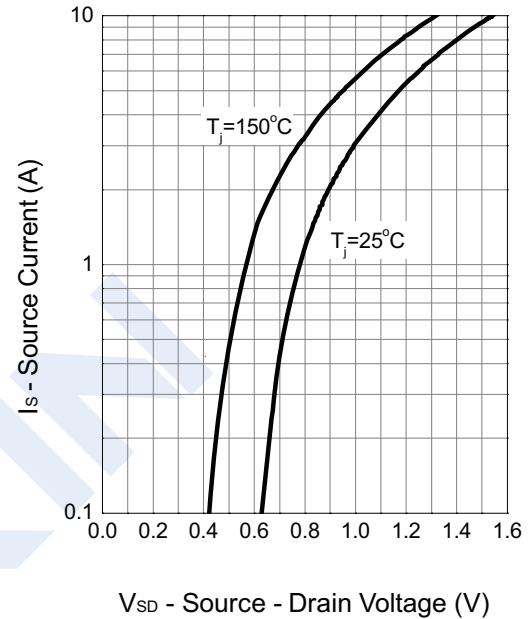

Capacitance

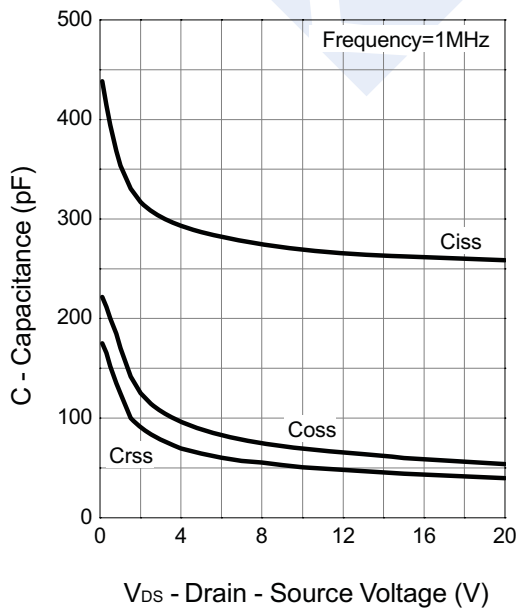

Gate Charge

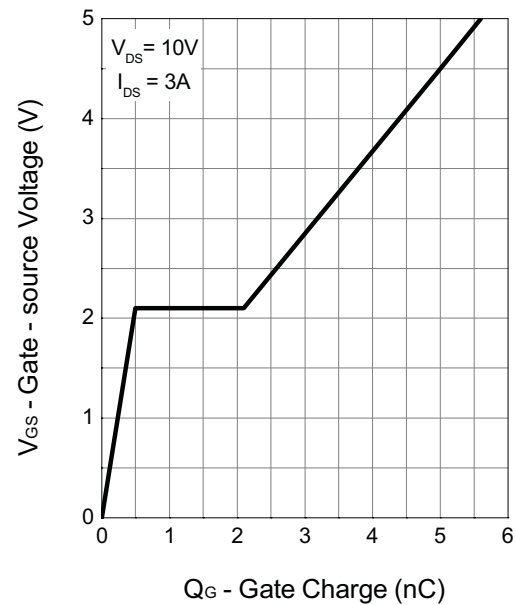

Dual MOSFET (N and P Channel)

APM2701

■ Typical Characteristics

P-Channel

Power Dissipation

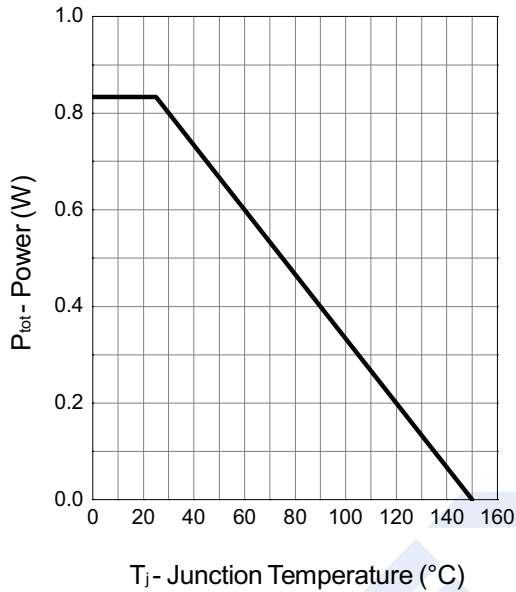

Drain Current

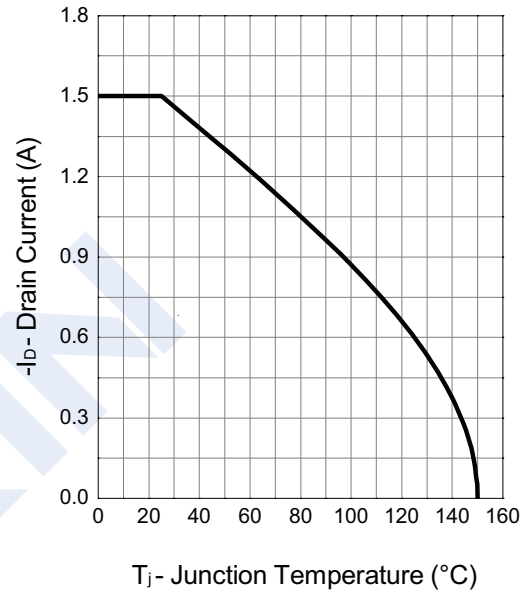

Safe Operation Area

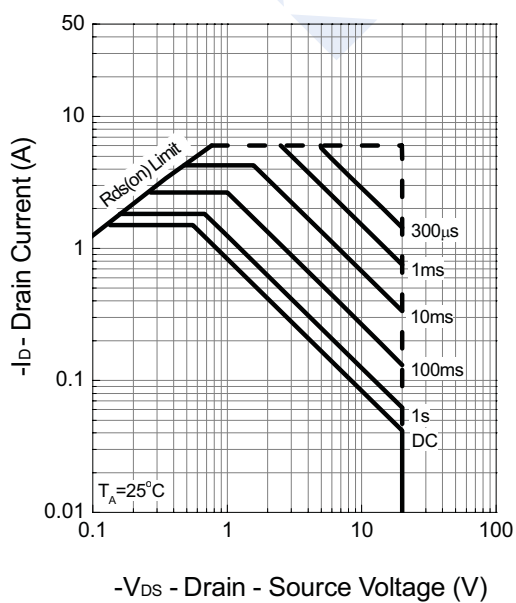

Thermal Transient Impedance

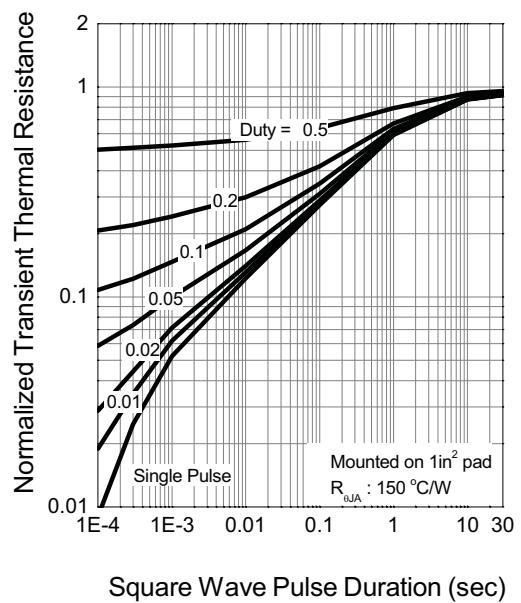

Dual MOSFET (N and P Channel)

APM2701

■ Typical Characteristics (Cont.)

Output Characteristics

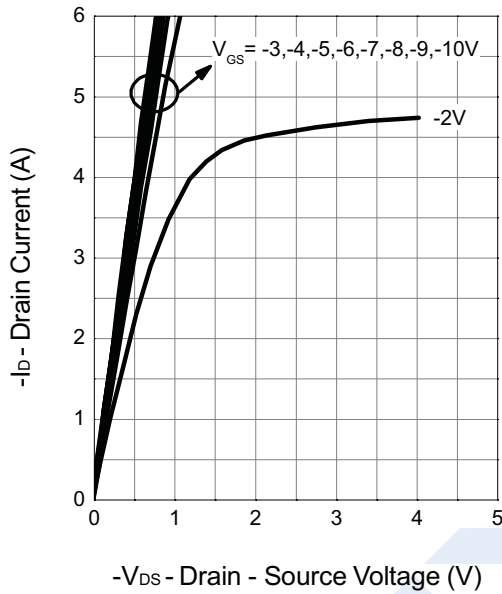

Drain-Source On Resistance

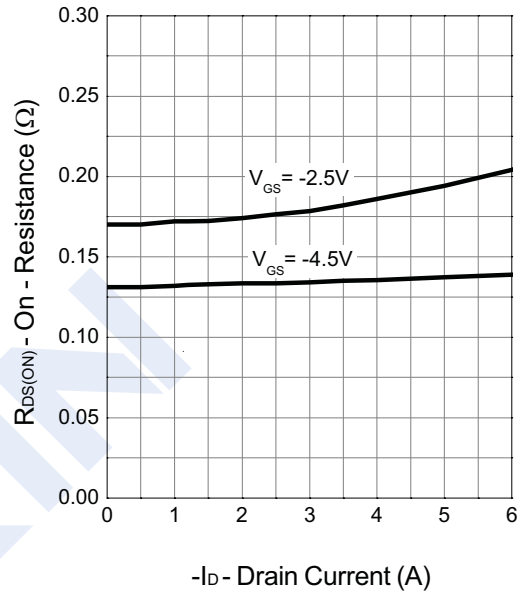

Transfer Characteristics

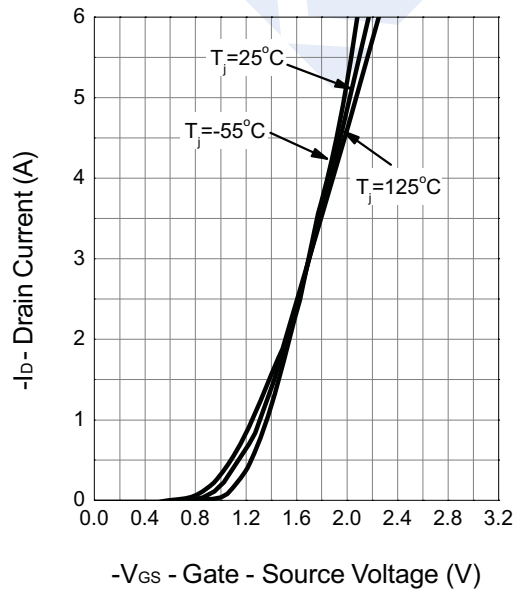

Gate Threshold Voltage

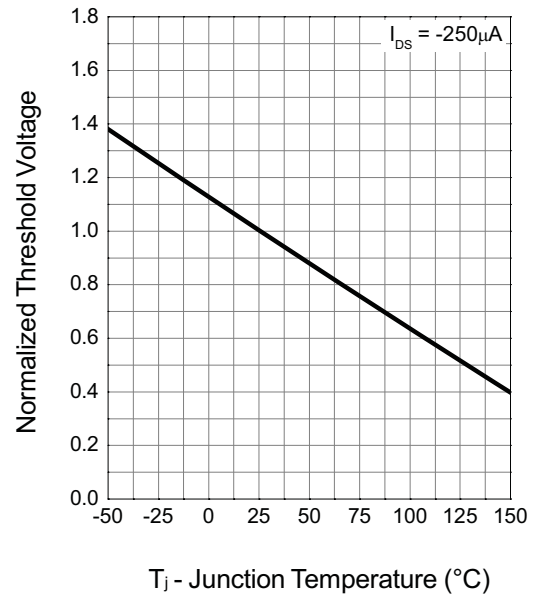

Dual MOSFET (N and P Channel)

APM2701

■ Typical Characteristics (Cont.)

Drain-Source On Resistance

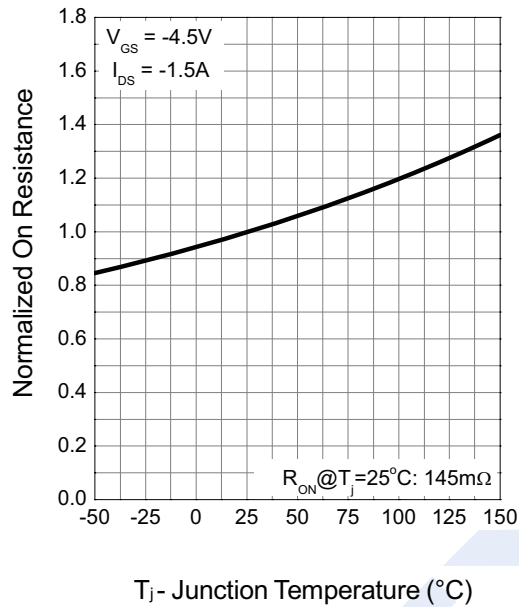

Source-Drain Diode Forward

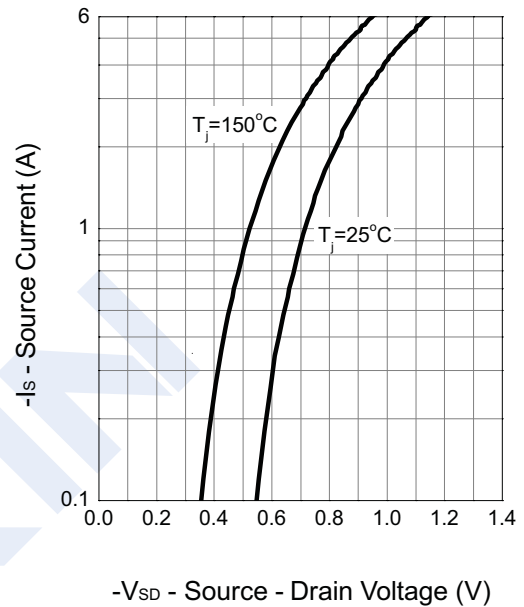

Capacitance

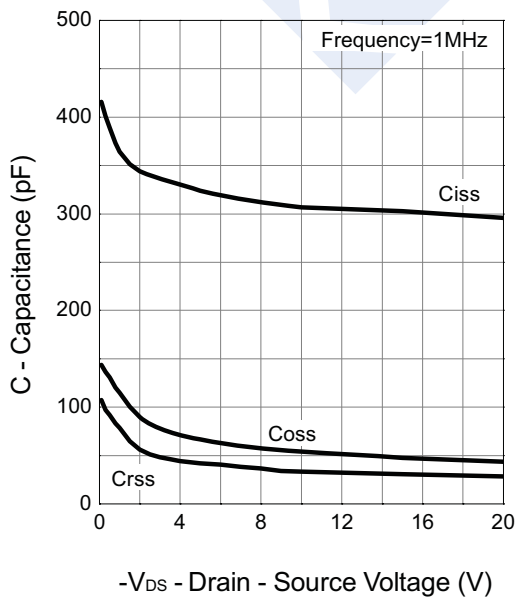

Gate Charge

