

Differential Positive ECL (DPECL) SU-A29F0 Series

Description

The **SU-A29F0 Series** of quartz crystal oscillators provide DPECL compatible signals. Systems designers may now specify space-saving, cost-effective packaged PECL oscillators to meet their timing requirements.

Features

- Wide frequency range – 280.0+MHz to 350.0MHz
- User specified tolerance available
- Space-saving alternative to discrete component oscillators
- High shock resistance, to 1000g
- 3.3 volt operation
- High Reliability - NEL HALT/HASS qualified for crystal oscillator start-up conditions
- COTS/Dual use
- Wavecrest jitter characterization available
- Overtone technology
- High Q Crystal actively tuned oscillator circuit
- No internal PLL avoids cascading PLL problems
- Power supply decoupling internal
- Metal lid electrically connected to ground to reduce EMI
- Gold plated pads

Electrical Connection

Pin Connection

- | | |
|---|-----------------|
| 1 | Enable |
| 2 | N/C |
| 3 | Ground |
| 4 | Q Output |
| 5 | /Q Output |
| 6 | V _{CC} |

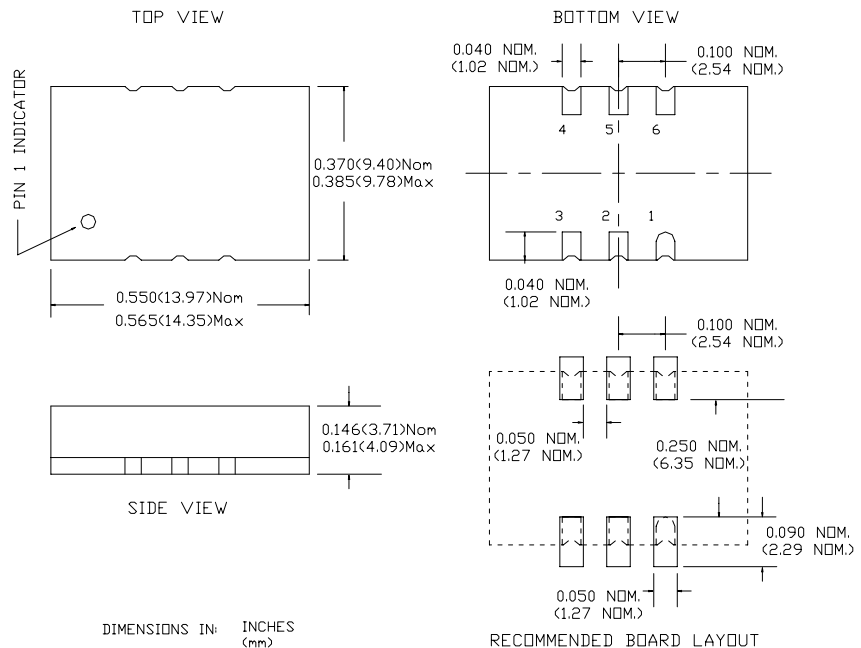

SU-A29F0 Series Continued
Differential Positive ECL (DPECL)

Rev. K

Operating Conditions and Output Characteristics (8)

Electrical Characteristics

Parameter	Symbol	Conditions	Min	Typical	Max
Frequency	-----	-----	280.0+MHz	-----	350.0MHz
Duty Cycle	-----	@ V _{CC} -1.29V	45/55%	-----	55/45%
Logic 0 ⁽²⁾⁽⁷⁾	V _{OL}	-----	-----	-----	V _{CC} -1.62V
Logic 1 ⁽²⁾⁽⁷⁾	V _{OH}	-----	V _{CC} -1.025V	-----	-----
Rise & Fall Time	tr,tf	20-80%V _O with 50 ohm load to V _{CC} -2V	-----	-----	500ps
T _{pd} ⁽⁶⁾	-----	-----	-200psec	-----	+200psec
Jitter, RMS ⁽³⁾	-----	-----	-----	-----	1 ps
Enable Voltage ⁽⁵⁾	-----	with V _{EE} = 0V	2.0V	-----	-----
Disable Voltage	-----	with V _{EE} = 0V	-----	-----	0.8V
Frequency Stability ⁽¹⁾	dF/F	Overall conditions including: voltage, calibration, temp., 10 yr aging, shock, vibration	-100ppm	-----	+100ppm

General Characteristics

Parameter	Symbol	Conditions	Min	Typical	Max
Supply Voltage ⁽⁴⁾	V _{CC}	3.3V±5%	3.135V	3.3V	3.465V
Supply Current	I _{CC}	50 ohm termination To 2.00V below V _{CC}	0.0 mA	-----	105 mA
Output current	I _O	Low level Output Current	0.0 mA	-----	±50.0 mA
Operating temperature	T _A	-----	0°C	-----	70°C
Storage temperature	T _S	-----	-55°C	-----	125°C
Power Dissipation	P _D	-----	-----	-----	364 mW
Load ⁽⁷⁾	-----	50 Ohm to V _{CC} -2V or Thevenin Equivalent, Bias Required	-----	-----	-----
Start-up time	t _s	-----	-----	2 ms	10 ms

Environmental and Mechanical Characteristics

Mechanical Shock	Per MIL-STD-202, Method 213, Condition E
Thermal Shock	Per MIL-STD-883, Method 1011, Condition A
Vibration	0.060" double amplitude 10 Hz to 55 Hz, 35g's 55Hz to 2000 Hz

Footnotes:

- Standard frequency stability (±20,±25,±50ppm & others available)
- V_{OL}, V_{OH}, referenced to ground (V_{EE}) with V_{CC} = 3.3V
- Jitter performance is frequency dependent. Please contact factory for full Wavecrest characterization.
RMS jitter bandwidth of 12kHz to 20MHz.
- Internal high frequency power source decoupling.
- Open to enable pin also enables the output.
- T_{pd} is phase shift between the falling edge of pin 4 at 2.0V and the rising edge of pin 5 at 2.01V.
- Logic levels are dependant on specified load of 50 ohms to V_{CC}-2 volts.
- All parameters, unless otherwise specified, are at nominal conditions, ie: T=25°C, Nominal Vcc & Nominal load.

Creating a Part Number	
SU - A29FX - FREQ	
Package Code	Tolerance/Performance
SU 6 pad 9x14mm SMD	0 ±100ppm 0-70°C
	1 ±50ppm 0-70°C
	7 ±25ppm 0-70°C
	9 Customer Specific
Input Voltage	A ±20ppm 0-70°C
Code Specification	B ±50ppm -40 to +85°C
A 3.3V	C ±100ppm -40 to +85°C
B 2.5V	

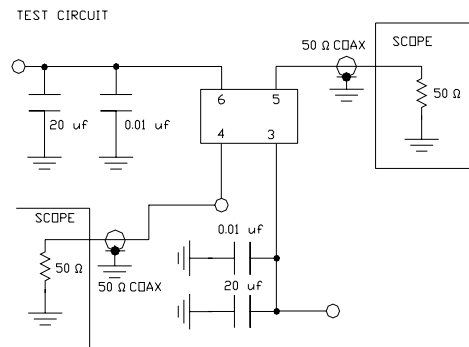

TEST CIRCUIT USES A SPLIT SUPPLY OF +2V AND -1.3V FOR EASE OF TESTING.

SU-A29F0 Series Continued

Max Reflow Profile

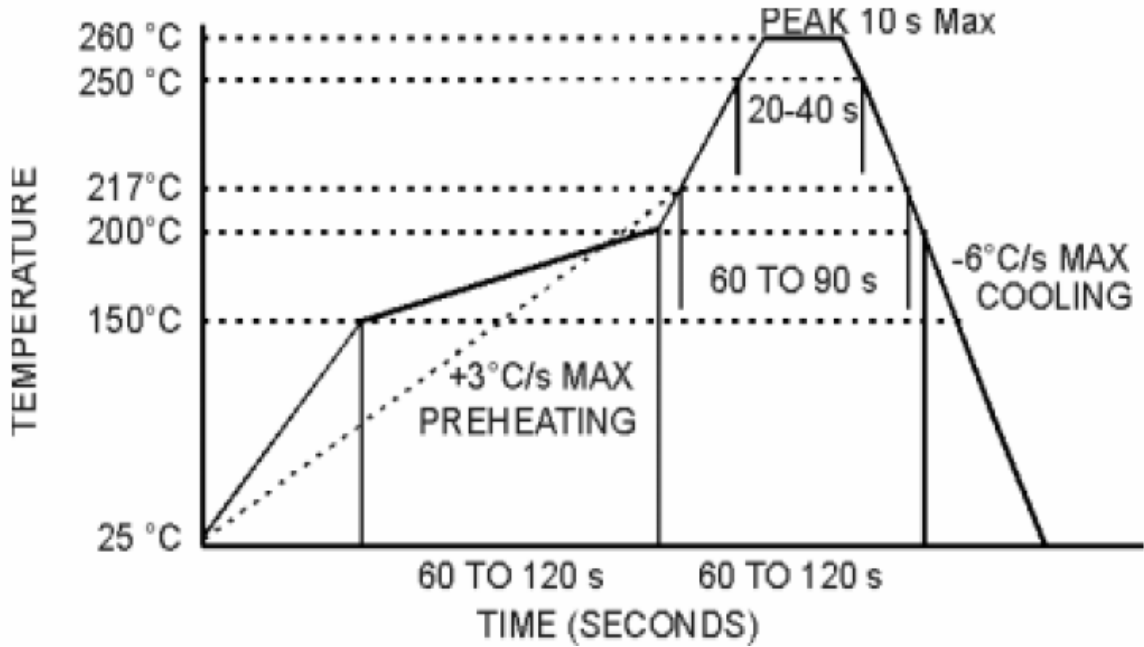

The device may be reflowed once. Reflowing upside down is not allowed. NO CLEAN assembly is recommended.