

P4C188/P4C188L ULTRA HIGH SPEED 16K x 4 STATIC CMOS RAMS



FEATURES

- Full CMOS, 6T Cell
- High Speed (Equal Access and Cycle Times)
 - 10/12/15/20/25 ns (Commercial)
 - 12/15/20/25/35 (Industrial)
 - 15/20/25/35/45 ns (Military)
- Low Power (Commercial/Military)
 - 715 mW Active - 12/15
 - 550/660 mW Active - 20/25/35/45
 - 193/220 mW Standby (TTL Input)
 - 83/110 mW Standby (CMOS Input) P4C188
 - 15 mW Standby (CMOS Input) (P4C188L Military)
- Single 5V±10% Power Supply
- Data Retention with 2.0V Supply (P4C188L Military)
- Three-State Outputs
- TTL/CMOS Compatible Outputs
- Fully TTL Compatible Inputs
- Standard Pinout (JEDEC Approved)
 - 22-Pin 300 mil DIP
 - 24-Pin 300 mil SOJ
 - 22-Pin 290 x 490 mil LCC



DESCRIPTION

The P4C188 and P4C188L are 65,536-bit ultra high speed static RAMs organized as 16K x 4. The CMOS memories require no clocks or refreshing and have equal access and cycle times. Inputs and outputs are fully TTL-compatible. The RAMs operate from a single 5V±10% tolerance power supply. With battery backup, data integrity is maintained for supply voltages down to 2.0V. Current drain is typically 10 µA from a 2.0V supply.

Access times as fast as 10 nanoseconds are available, permitting greatly enhanced system speeds. CMOS is utilized to reduce power consumption to a low 715mW active, 193mW standby and only 5mW in the P4C188L version.

The P4C188 and P4C188L are available in 22-pin 300 mil DIP, 24-pin 300 mil SOJ and 22-pin LCC packages providing excellent board level densities.



FUNCTIONAL BLOCK DIAGRAM

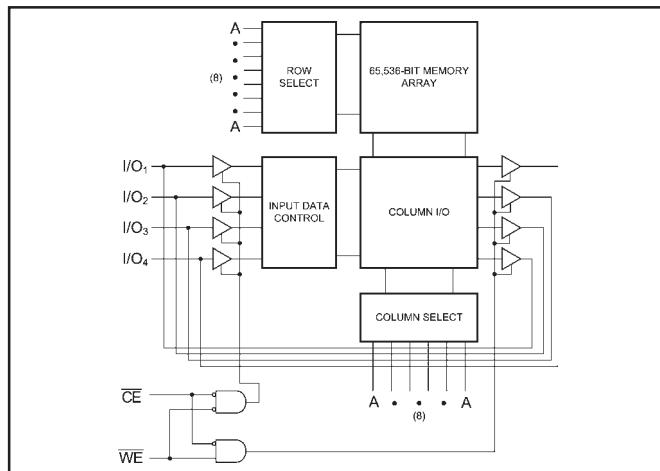

PIN CONFIGURATIONS

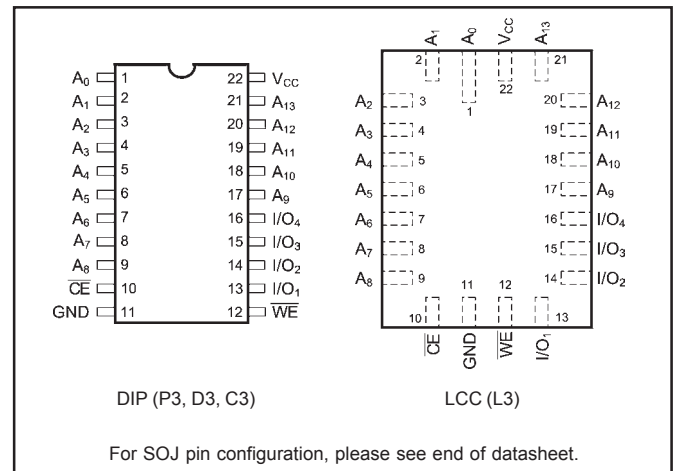

MAXIMUM RATINGS⁽¹⁾

Symbol	Parameter	Value	Unit
V _{CC}	Power Supply Pin with Respect to GND	-0.5 to +7	V
V _{TERM}	Terminal Voltage with Respect to GND (up to 7.0V)	-0.5 to V _{CC} +0.5	V
T _A	Operating Temperature	-55 to +125	°C

Symbol	Parameter	Value	Unit
T _{BIAS}	Temperature Under Bias	-55 to +125	°C
T _{STG}	Storage Temperature	-65 to +150	°C
P _T	Power Dissipation	1.0	W
I _{OUT}	DC Output Current	50	mA

RECOMMENDED OPERATING TEMPERATURE AND SUPPLY VOLTAGE

Grade(2)	Ambient Temperature	GND	V _{CC}
Military	-55°C to +125°C	0V	5.0V ± 10%
Industrial	-40°C to +85°C	0V	5.0V ± 10%
Commercial	0°C to +70°C	0V	5.0V ± 10%

CAPACITANCES⁽⁴⁾

V_{CC} = 5.0V, T_A = 25°C, f = 1.0MHz

Symbol	Parameter	Conditions	Typ.	Unit
C _{IN}	Input Capacitance	V _{IN} = 0V	5	pF
C _{OUT}	Output Capacitance	V _{OUT} = 0V	7	pF

DC ELECTRICAL CHARACTERISTICS

Over recommended operating temperature and supply voltage⁽²⁾

Symbol	Parameter	Test Conditions	P4C188		P4C188L		Unit
			Min	Max	Min	Max	
V _{IH}	Input High Voltage		2.2	V _{CC} +0.5	2.2	V _{CC} +0.5	V
V _{IL}	Input Low Voltage		-0.5 ⁽³⁾	0.8	-0.5 ⁽³⁾	0.8	V
V _{HC}	CMOS Input High Voltage		V _{CC} -0.2	V _{CC} +0.5	V _{CC} -0.2	V _{CC} +0.5	V
V _{LC}	CMOS Input Low Voltage		-0.5 ⁽³⁾	0.2	-0.5(3)	0.2	V
V _{CD}	Input Clamp Diode Voltage	V _{CC} = Min., I _{IN} = 18 mA		-1.2		-1.2	V
V _{OL}	Output Low Voltage (TTL Load)	I _{OL} = +8 mA, V _{CC} = Min.		0.4		0.4	V
V _{OH}	Output High Voltage (TTL Load)	I _{OH} = -4 mA, V _{CC} = Min.	2.4		2.4		V
I _{LI}	Input Leakage Current	V _{CC} = Max. Mil.	-10	+10	-5	+5	µA
		V _{IN} = GND to V _{CC} Com'l.	-5	+5	n/a	n/a	
I _{LO}	Output Leakage Current	V _{CC} = Max., $\overline{CE} = V_{IH}$ Mil.	-10	+10	-5	+5	µA
		V _{OUT} = GND to V _{CC} Com'l.	-5	+5	n/a	n/a	
I _{SB}	Standby Power Supply Current (TTL Input Levels)	$\overline{CE} \geq V_{IH}$ Mil.	—	40	—	40	mA
		V _{CC} = Max., Ind./Com'l. f = Max., Outputs Open	—	35	—	n/a	
I _{SB1}	Standby Power Supply Current (CMOS Input Levels)	$\overline{CE} \geq V_{HC}$ Mil.	—	20	—	2.7	mA
		V _{CC} = Max., Ind./Com'l. f = 0, Outputs Open V _{IN} ≤ V _{LC} or V _{IN} ≥ V _{HC}	—	15	—	n/a	

n/a = Not Applicable

Notes:

- Stresses greater than those listed under MAXIMUM RATINGS may cause permanent damage to the device. This is a stress rating only and functional operation of the device at these or any other conditions above those indicated in the operational sections of this specification is not implied. Exposure to MAXIMUM rating conditions for extended periods may affect reliability.
- Extended temperature operation guaranteed with 400 linear feet per minute of air flow.
- Transient inputs with V_{IL} and I_{IL} not more negative than -3.0V and -100mA, respectively, are permissible for pulse widths up to 20ns.
- This parameter is sampled and not 100% tested.

POWER DISSIPATION CHARACTERISTICS VS. SPEED

Symbol	Parameter	Temperature Range	-10	-12	-15	-20	-25	-35	-45	Unit
I_{CC}	Dynamic Operating Current*	Commercial	180	170	160	155	150	N/A	N/A	mA
		Industrial	N/A	180	170	160	155	150	N/A	mA
		Military	N/A	N/A	170	160	155	150	145	mA

* $V_{CC} = 5.5V$. Tested with outputs open. $f = \text{Max}$. Switching inputs are 0V and 3V. $\overline{CE} = V_{IL}$

DATA RETENTION CHARACTERISTICS (P4C188L Military Temperature Only)

Symbol	Parameter	Test Conditions	Min	Typ.*		Max		Unit
				$V_{CC} = 2.0V$	$V_{CC} = 3.0V$	$V_{CC} = 2.0V$	$V_{CC} = 3.0V$	
V_{DR}	V_{CC} for Data Retention		2.0					V
I_{CCDR}	Data Retention Current	$\overline{CE} \geq V_{CC} - 0.2V$, $V_{IN} \geq V_{CC} - 0.2V$ or $V_{IN} \leq 0.2V$		10	15	600	900	μA
t_{CDR}	Chip Deselect to Data Retention Time		0					ns
t_R^\dagger	Operation Recovery Time		t_{RC}^\S					ns

* $T_A = +125^\circ C$

$^\S t_{RC}$ = Read Cycle Time

† This parameter is guaranteed but not tested.

DATA RETENTION WAVEFORM

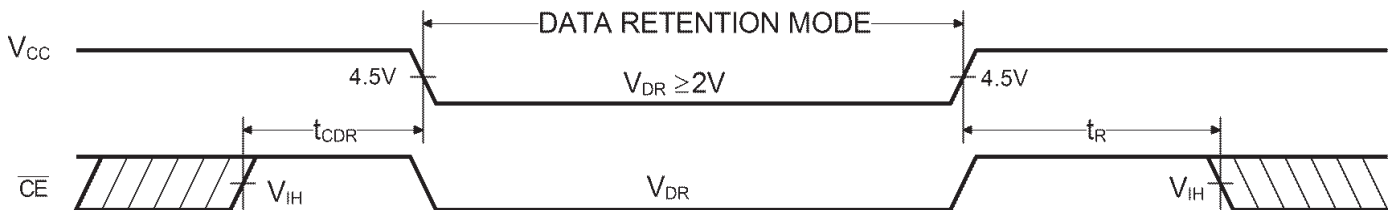

AC CHARACTERISTICS—READ CYCLE

($V_{CC} = 5V \pm 10\%$, All Temperature Ranges)⁽²⁾

Sym.	Parameter	-10		-12		-15		-20		-25		-35		-45		Unit
		Min	Max	Min	Max	Min	Max	Min	Max	Min	Max	Min	Max	Min	Max	
t_{RC}	Read Cycle Time	10		12		15		20		25		35		45		ns
t_{AA}	Address Access Time		10		12		15		20		25		35		45	ns
t_{AC}	Chip Enable Access Time		10		12		15		20		25		35		45	ns
t_{OH}	Output Hold from Address Change	2		2		2		2		2		2		2		ns
t_{LZ}	Chip Enable to Output in Low Z	2		2		2		3		3		3		3		ns
t_{HZ}	Chip Disable to Output in High Z		5		6		6		8		10		20		25	ns
t_{PU}	Chip Enable to Power Up Time	0		0		0		0		0		0		0		ns
t_{PD}	Chip Disable to Power Down Time		10		12		15		20		25		35		45	ns

TIMING WAVEFORM OF READ CYCLE NO. 1⁽⁵⁾

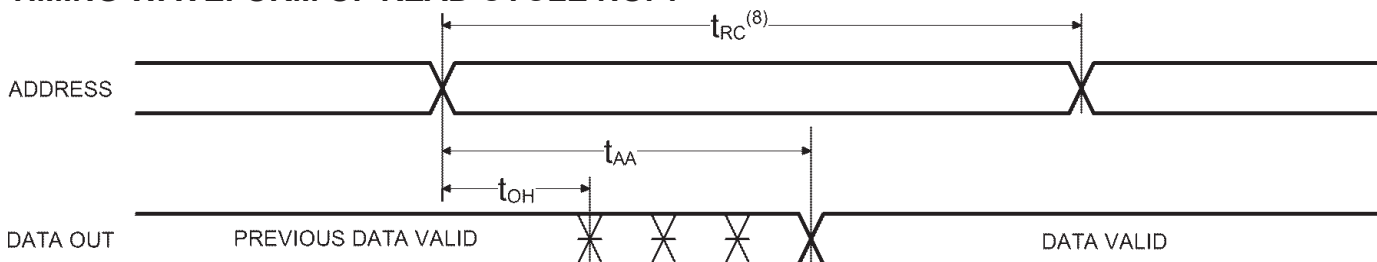

TIMING WAVEFORM OF READ CYCLE NO. 2⁽⁶⁾

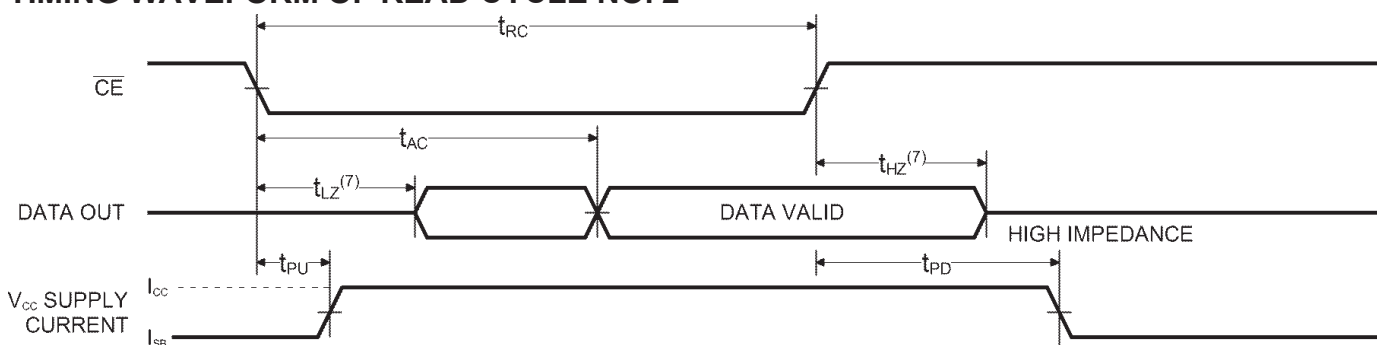

Notes:

- 5. \overline{CE} is LOW and \overline{WE} is HIGH for READ cycle.
- 6. \overline{WE} is HIGH, and address must be valid prior to or coincident with \overline{CE} transition LOW.

- 7. Transition is measured $\pm 200mV$ from steady state voltage prior to change with specified loading in Figure 1. This parameter is sampled and not 100% tested.
- 8. Read Cycle Time is measured from the last valid address to the first transitioning address.

AC CHARACTERISTICS - WRITE CYCLE

($V_{CC} = 5V \pm 10\%$, All Temperature Ranges)⁽²⁾

Sym.	Parameter	-10		-12		-15		-20		-25		-35		-45		Unit
		Min	Max	Min	Max	Min	Max	Min	Max	Min	Max	Min	Max	Min	Max	
t_{WC}	Write Cycle Time	10		12		13		20		25		35		45		ns
t_{CW}	Chip Enable Time to End of Write	7		8		10		13		15		25		35		ns
t_{AW}	Address Valid to End of Write	7		8		10		15		20		25		35		ns
t_{AS}	Address Set-up Time	0		0		0		0		0		0		0		ns
t_{WP}	Write Pulse Width	8		9		10		13		15		25		35		ns
t_{AH}	Address Hold Time from End of Write	0		0		0		0		0		0		0		ns
t_{DW}	Data Valid to End of Write	5		6		7		8		10		15		20		ns
t_{DH}	Data Hold Time	0		0		0		0		0		0		5		ns
t_{WZ}	Write Enable to Output in High Z		5		6		6		8		10		15		20	ns
t_{DW}	Output Active from End of Write	2		2		2		2		2		3		3		ns

TIMING WAVEFORM OF WRITE CYCLE NO. 1 (\overline{WE} CONTROLLED)⁽⁹⁾

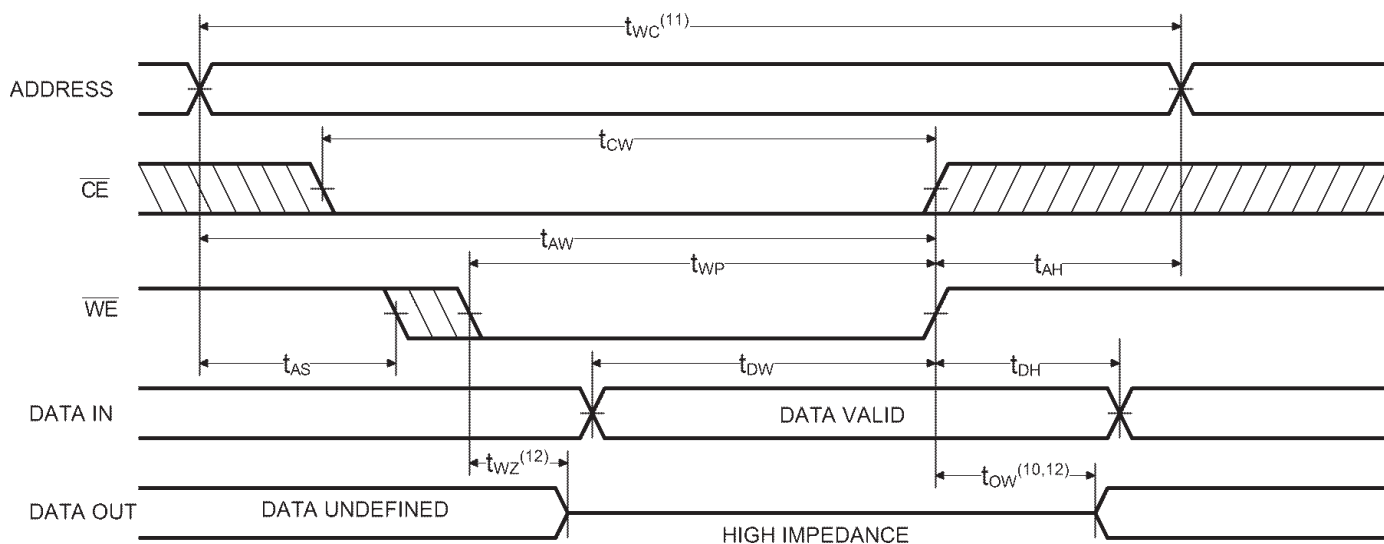

Notes:

- \overline{CE} and \overline{WE} must be LOW for WRITE cycle.
- If \overline{CE} goes HIGH simultaneously with \overline{WE} HIGH, the output remains in a high impedance state.
- Write Cycle Time is measured from the last valid address to the first transition address.

- Transition is measured $\pm 200\text{mV}$ from steady state voltage prior to change with specified loading in Figure 1. This parameter is sampled and not 100% tested.

TIMING WAVEFORM OF WRITE CYCLE NO. 2 ($\overline{\text{CE}}$ CONTROLLED)⁽⁹⁾

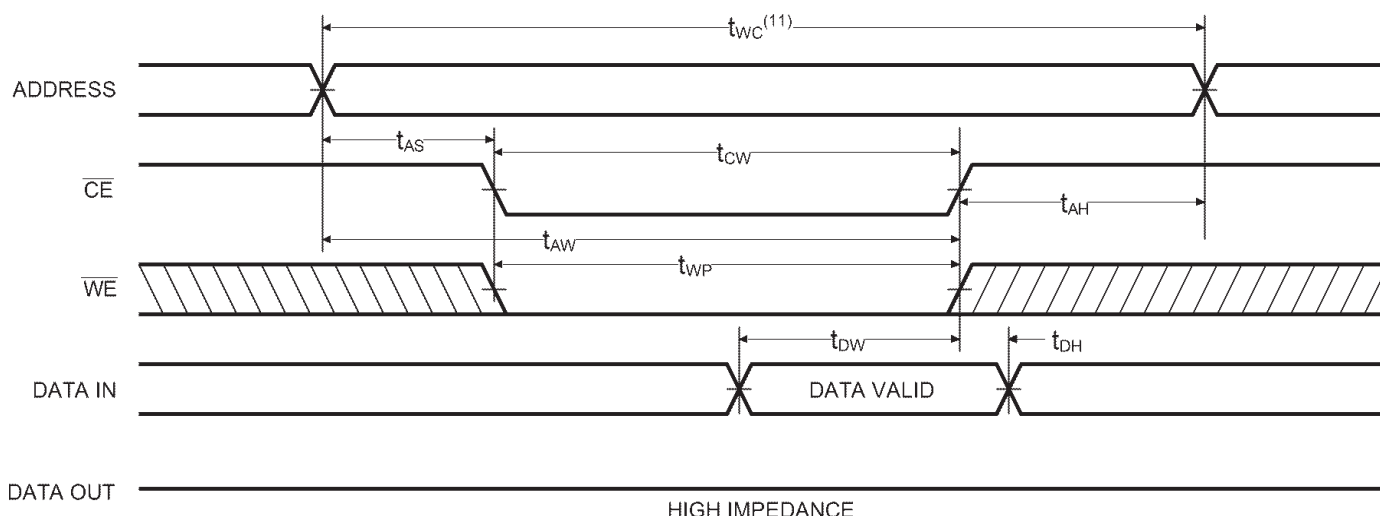

AC TEST CONDITIONS

Input Pulse Levels	GND to 3.0V
Input Rise and Fall Times	3ns
Input Timing Reference Level	1.5V
Output Timing Reference Level	1.5V
Output Load	See Figures 1 and 2

TRUTH TABLE

Mode	$\overline{\text{CE}}$	$\overline{\text{WE}}$	Output	Power
Standby	H	X	High Z	Standby
Read	L	H	D_{OUT}	Active
Write	L	L	D_{IN}	Active

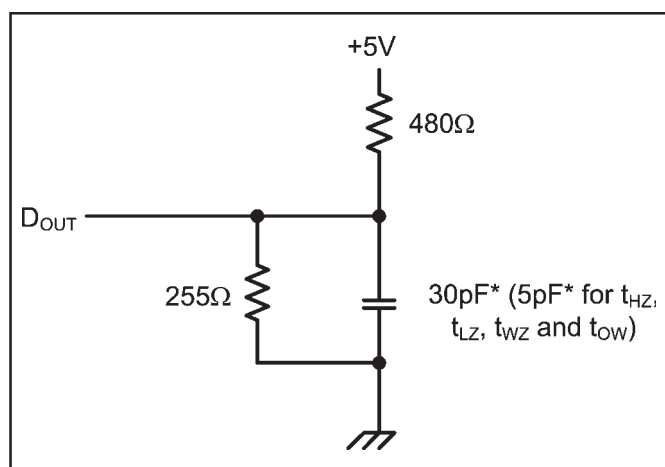

Figure 1. Output Load

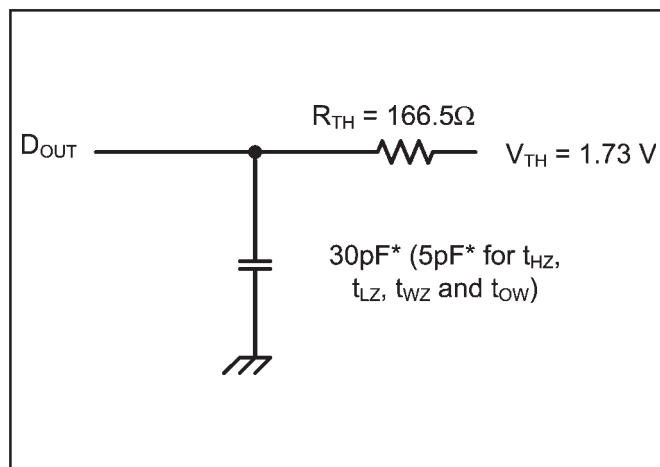

Figure 2. Thevenin Equivalent

* including scope and test fixture.

Note:

Because of the ultra-high speed of the P4C188/L, care must be taken when testing this device; an inadequate setup can cause a normal functioning part to be rejected as faulty. Long high-inductance leads that cause supply bounce must be avoided by bringing the V_{CC} and ground planes directly up to the contactor fingers. A 0.01 μF high frequency

capacitor is also required between V_{CC} and ground. To avoid signal reflections, proper termination must be used; for example, a 50 Ω test environment should be terminated into a 50 Ω load with 1.73V (Thevenin Voltage) at the comparator input, and a 116 Ω resistor must be used in series with D_{OUT} to match 166 Ω (Thevenin Resistance).

ORDERING INFORMATION

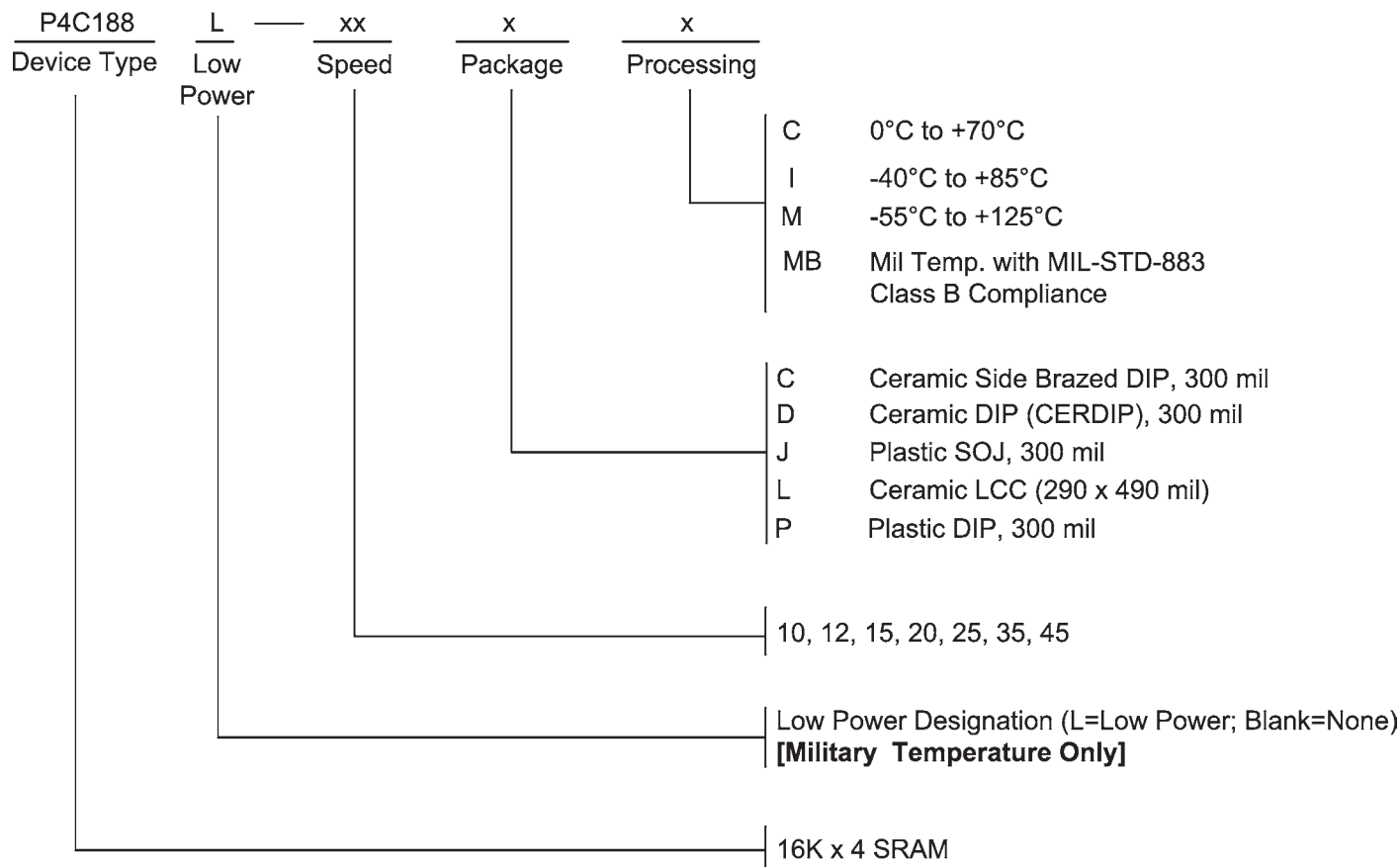

SELECTION GUIDE

The P4C188/L is available in the following temperature, speed and package options. The P4C188L is only available over the Military Temperature range.

Temperature Range	Package	Speed (ns)						
		10	12	15	20	25	35	45
Commercial	Plastic DIP	-10PC	-12PC	-15PC	-20PC	-25PC	-35PC	45PC
	Plastic SOJ	-10JC	-12JC	-15JC	-20JC	-25JC	-35JC	-45JC
Industrial	Plastic DIP	N/A	-12PI	-15PI	-20PI	-25PI	-35PI	-45PI
	Plastic SOJ	N/A	-12JI	-15JI	-20JI	-25JI	-35JI	-45JI
Military Temperature	Side Brazed DIP	N/A	N/A	-15CM	-20CM	-25CM	-35CM	-45CM
	CERDIP	N/A	N/A	-15DM	-20DM	-25DM	-35DM	-45DM
	LCC	N/A	N/A	-15LM	-20LM	-25LM	-35LM	-45LM
Military Processed*	Side Brazed DIP	N/A	N/A	-15CMB	-20CMB	-25CMB	-35CMB	-45CMB
	CERDIP	N/A	N/A	-15DMB	-20DMB	-25DMB	-35DMB	-45DMB
	LCC	N/A	N/A	-15LMB	-20LMB	-25LMB	-35LMB	-45LMB

* Military temperature range with MIL-STD-883, Class B processing.

N/A = Not Available

SOJ PIN CONFIGURATION

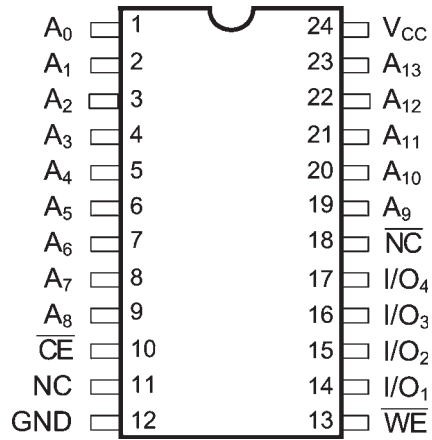

SOJ (J4)

Pkg #	C3	
# Pins	22 (300 mil)	
Symbol	Min	Max
A	0.100	0.200
b	0.014	0.023
b2	0.030	0.060
C	0.008	0.015
D	1.050	1.260
E	0.260	0.310
eA	0.300 BSC	
e	0.100 BSC	
L	0.125	0.200
Q	0.015	0.070
S1	0.005	-
S2	0.005	-

SIDE BRAZED DUAL IN-LINE PACKAGE

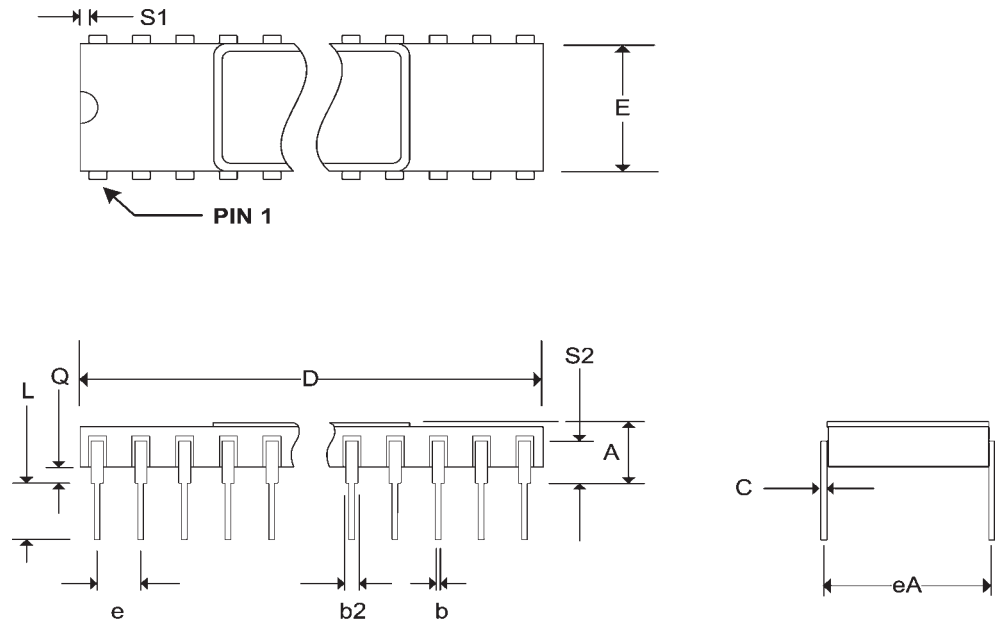

Pkg #	D3	
# Pins	22 (300 mil)	
Symbol	Min	Max
A	-	0.225
b	0.015	0.020
b2	0.045	0.065
C	0.009	0.012
D	1.060	1.110
E	0.290	0.320
eA	0.300 BSC	
e	0.100 BSC	
L	0.125	0.200
Q	0.015	0.060
S1	0.005	-
α	0°	15°

CERDIP DUAL IN-LINE PACKAGE

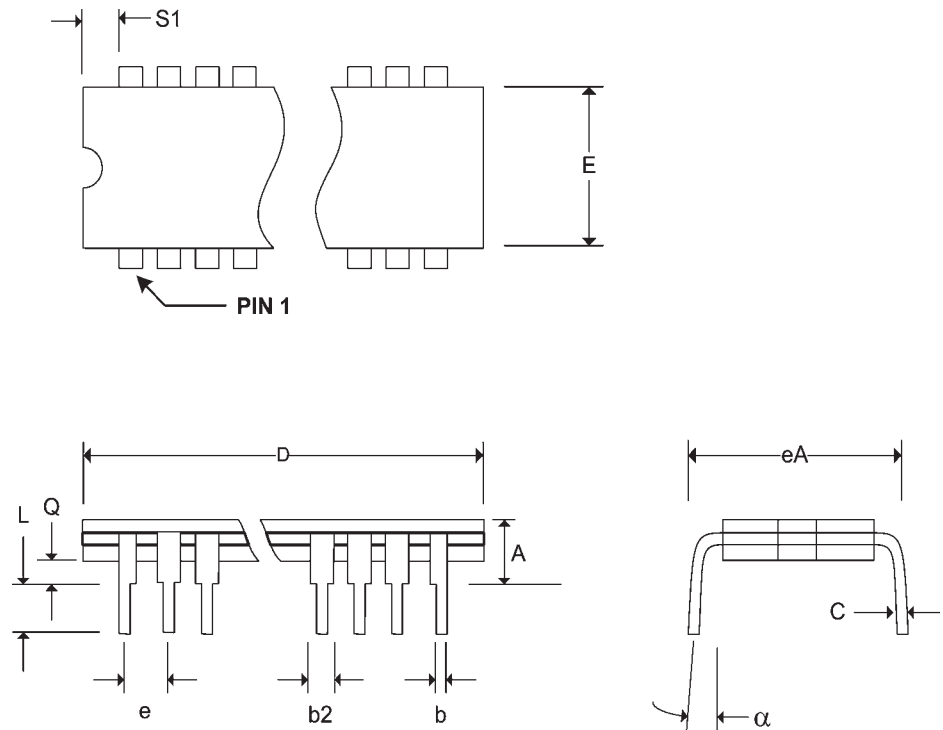

Pkg #	J4	
# Pins	24 (300 mil)	
Symbol	Min	Max
A	0.128	0.148
A1	0.082	-
b	0.016	0.020
C	0.007	0.010
D	0.620	0.630
e	0.050 BSC	
E	0.335 BSC	
E1	0.292	0.300
E2	0.267 BSC	
Q	0.025	-

SOJ SMALL OUTLINE IC PACKAGE

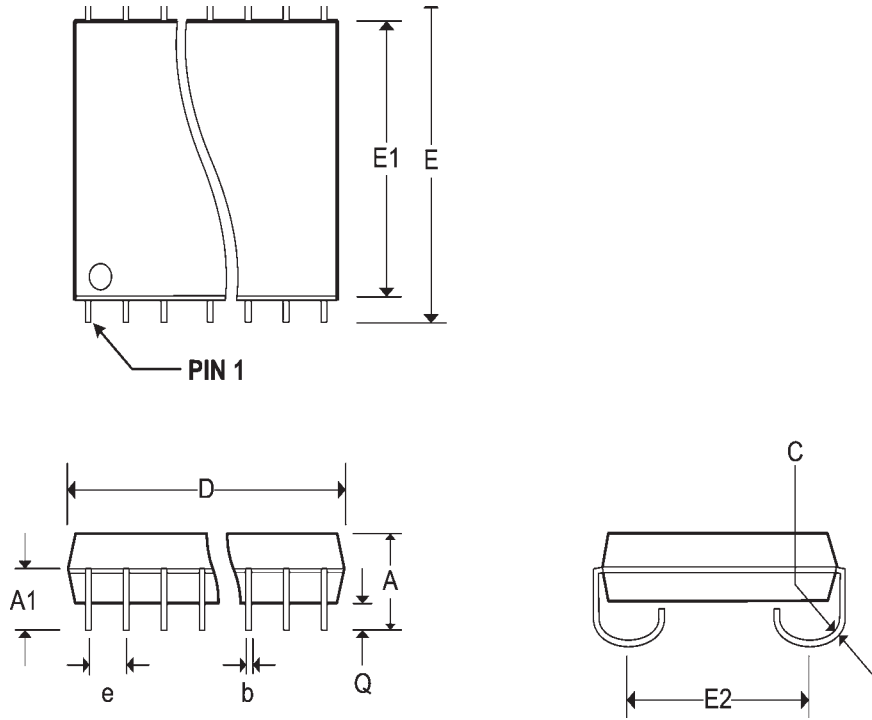

Pkg #	L3	
# Pins	22	
Symbol	Min	Max
A	0.060	0.080
A1	0.050	0.068
B1	0.022	0.028
D	0.284	0.296
D1	0.150 BSC	
D2	0.075 BSC	
D3	-	0.296
E	0.484	0.496
E1	0.300 BSC	
E2	0.150 BSC	
E3	-	0.496
e	0.050 BSC	
h	R = .012	
j	R = .012	
L	0.039	0.051
L1	0.039	0.051
L2	0.058	0.072
ND	4	
NE	7	

RECTANGULAR LEADLESS CHIP CARRIER

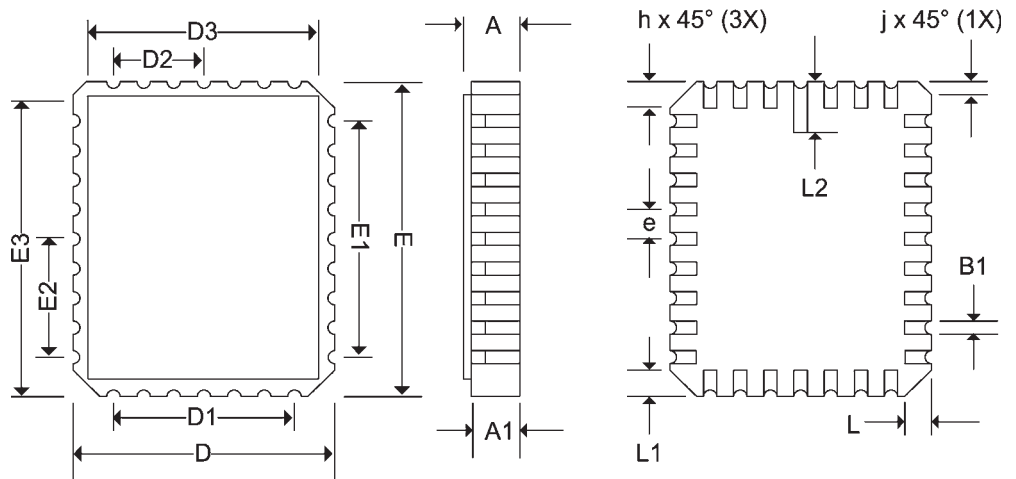

Pkg #	P3	
# Pins	22 (300 Mil)	
Symbol	Min	Max
A	-	0.210
A1	0.015	-
b	0.014	0.022
b2	0.045	0.070
C	0.008	0.014
D	1.145	1.165
E1	0.240	0.280
E	0.300	0.325
e	0.100 BSC	
eB	-	0.430
L	0.115	0.150
α	0°	15°

PLASTIC DUAL IN-LINE PACKAGE

