

NF3000A-VZF Series (RoHS Compliant)

3-phase 3-line 250VAC

Wide band & High attenuation



UL1283 (file No.E102708)
EN60939-2 (file No.R50031314)

Applications

Transmitter, Inverter. UPS, CVCF, VVVF

Specifications

Part No.	Rated Current	Weight	Dimensions [mm]																		
			A	B	C	D	E	F	G	H	J	K	L	M	N	P	Q	R	S	T	
NF3010A-VZF	10A	0.5Kg	128	118	108	63	43	42	1	4.5x6	dia.4.5	M4	M4	21	88	21	19	35	10	2	fig1
NF3020A-VZF	20A	0.5Kg	128	118	108	63	43	42	1	4.5x6	dia.4.5	M4	M4	21	88	21	19	35	10	2	
NF3030A-VZF	30A	0.7Kg	145	135	125	70	50	42	1	4.5x6	dia.4.5	M4	M4	25	103	22	20	35	10	2	
NF3040A-VZF	40A	1.3Kg	179	167	155	90	70	54	1.6	4.5x6	dia.4.5	M5	M4	32	131	25	23	45	14	3	
NF3050A-VZF	50A	1.3Kg	179	167	155	90	70	54	1.6	4.5x6	dia.4.5	M5	M4	32	131	25	23	45	14	3	
NF3060A-VZF	60A	1.5Kg	179	167	155	90	70	54	1.6	4.5x6	dia.4.5	M5	M4	32	131	25	23	45	14	3	
NF3080A-VZF	80A	3.0Kg	260	245	230	189	144.5	120	90	80	61	12	6.5	M8	M5	-	-	-	-	-	fig2
NF3100A-VZF	100A	3.0Kg	260	245	230	189	144.5	120	90	80	61	12	6.5	M8	M5	-	-	-	-	-	
NF3150A-VZF	150A	5.5Kg	285	270	255	216	171	170	100	105	89	67	6.5	M8	M8	-	-	-	-	-	fig3
Rated Voltage	250VAC																				
Leakage Current	1.5mA																				
Ambient temp.	-20 up to 50 Deg.C (TUV : -20 up to 60 Deg.C)																				

fig.1 (10-60A)

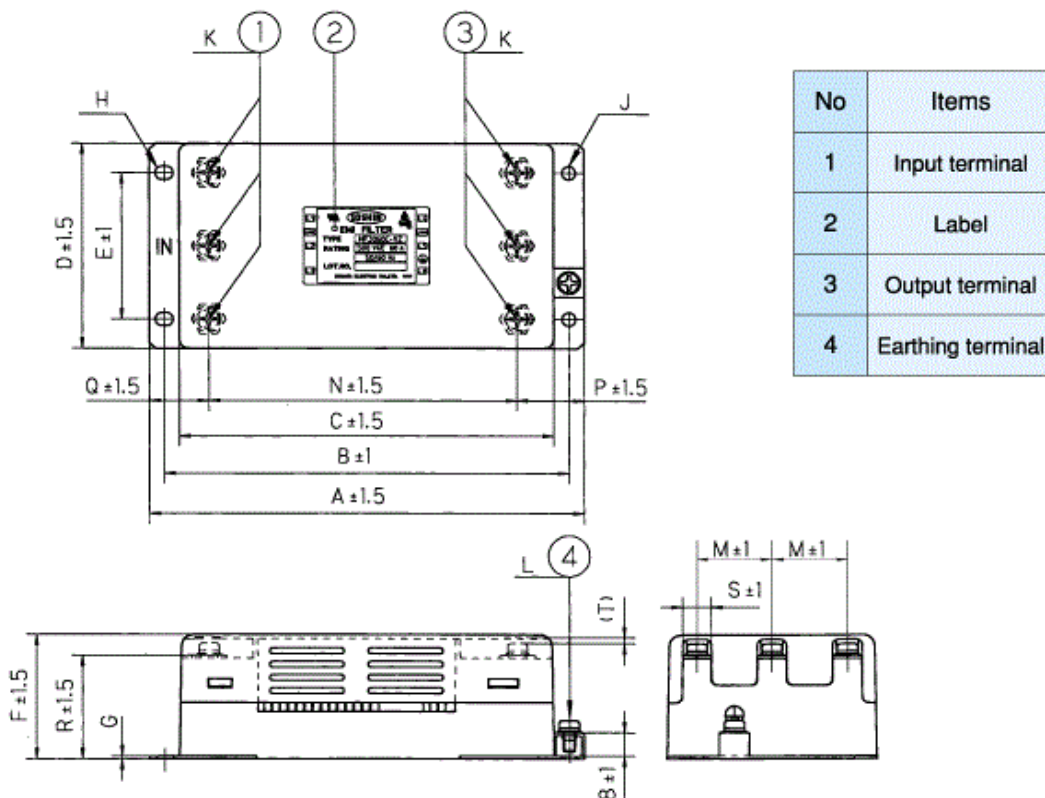
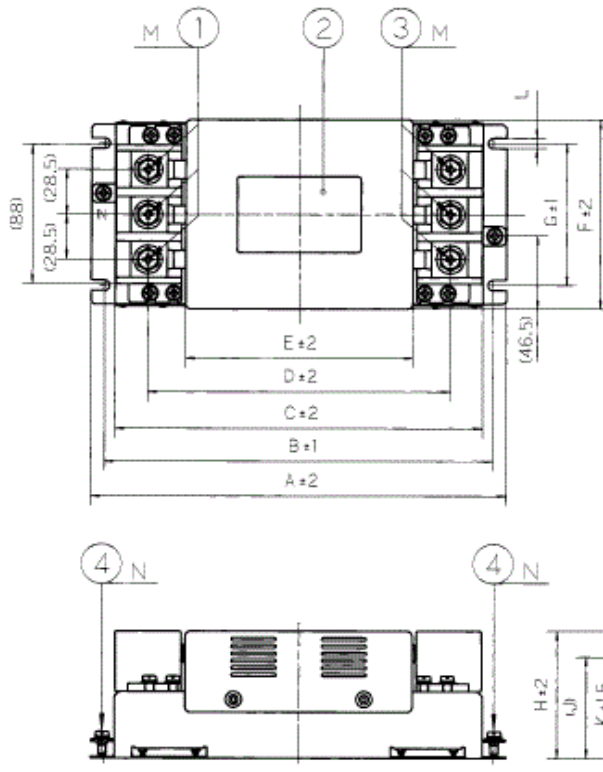
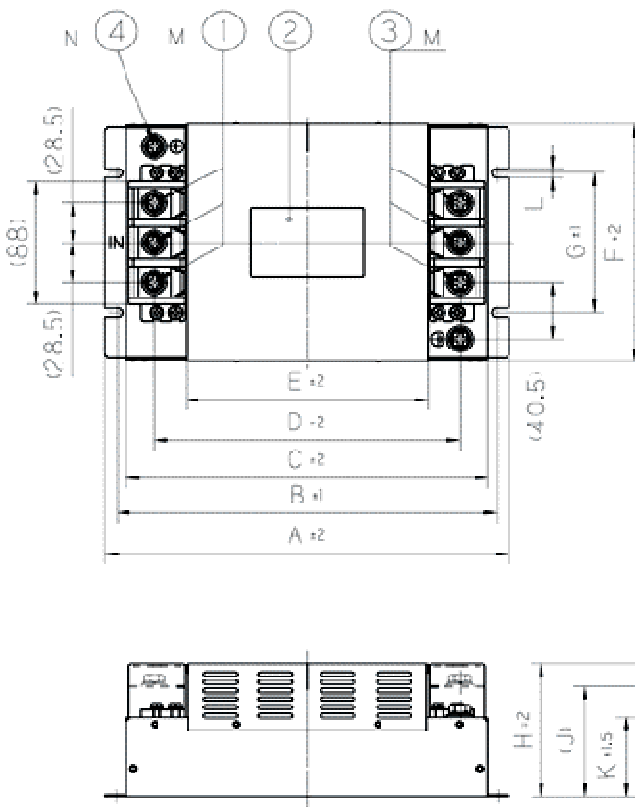

fig.2 (80, 100A)



No	Items
1	Input terminal
2	Label
3	Output terminal
4	Earthing terminal

fig.3 (150A)



No	Items
1	Input terminal
2	Label
3	Output terminal
4	Earthing terminal

Characteristics (Typical) (50A)

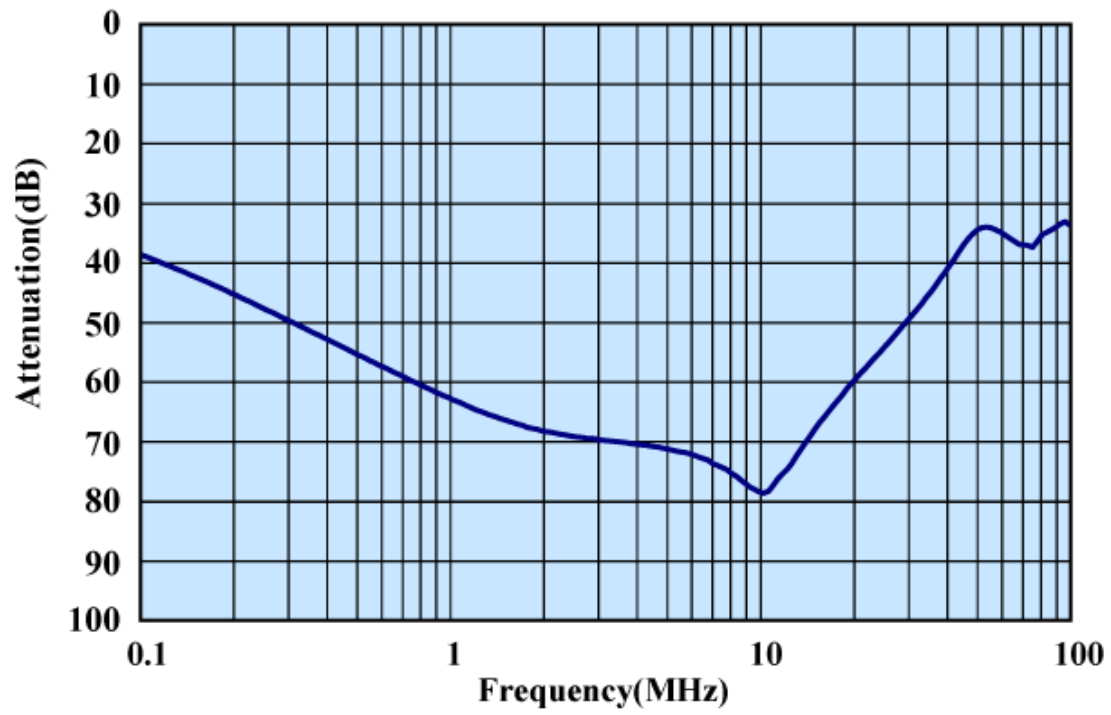

Circuit Diagram

