

**PLEASE CHECK WWW.MOLEX.COM FOR LATEST PART INFORMATION**

**Part Number:** [0190710281](#)  
**Status:** **Active**  
**Description:** InsulKrimp™ Ring Tongue Terminal for 2 AWG Wire

**Documents:**

[Drawing \(PDF\)](#) [RoHS Certificate of Compliance \(PDF\)](#)  
[Product Specification PS-19902-009 \(PDF\)](#)

**General**

Product Family	Ring and Spade Terminals
Series	<a href="#">19071</a>
Crimp Quality Equipment	Yes
Mil-Spec	N/A
Product Name	InsulKrimp™
Type	Ring

**Physical**

Barrel Type	Closed
Color - Resin	Natural
Insulation	PVC
Material - Plating Mating	Tin
Packaging Type	Bag
Stud Size	1/4" (M6)
Wire Insulation Diameter	16.50mm (.650") max.
Wire Size AWG	2

**Material Info**

Old Part Number	G-675-14X
-----------------	-----------

**Reference - Drawing Numbers**

Product Specification	PS-19902-009
Sales Drawing	SD-19071-005

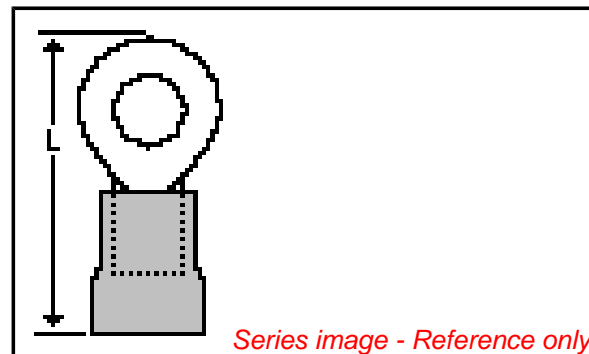

**EU RoHS**

**ELV and RoHS  
Compliant**  
**REACH SVHC**  
 Not Reviewed  
**Halogen-Free  
Status**  
**Not Reviewed**

**China RoHS**



**Need more information on product  
environmental compliance?**

Email [productcompliance@molex.com](mailto:productcompliance@molex.com)  
 For a multiple part number RoHS Certificate of  
 Compliance, [click here](#)

Please visit the [Contact Us](#) section for any  
 non-product compliance questions.

**Search Parts in this Series**

[19071Series](#)

**Application Tooling | [FAQ](#)**

*Tooling specifications and manuals are  
 found by selecting the products below.  
 Crimp Height Specifications are then  
 contained in the Application Tooling  
 Specification document.*

**Global**

Description	Product #
Manual Putt Pump Hydraulic System, Die set required	<a href="#">0192860117</a>
Die Set (large) for the HHLS Hydraulic Crimper	<a href="#">0192890010</a>
Hand Crimp Tool	<a href="#">0640013900</a>
Putt Pump Dieless Head System	<a href="#">0192860065</a>

MATERIAL: Copper  
 PLATING: Electro-Tin (.0003 Min.)  
 INSULATION: PVC COLOR CODED RED  
 STUD SIZES: ("D" ±.005)

INSULKRIMP X

\*Optional Style

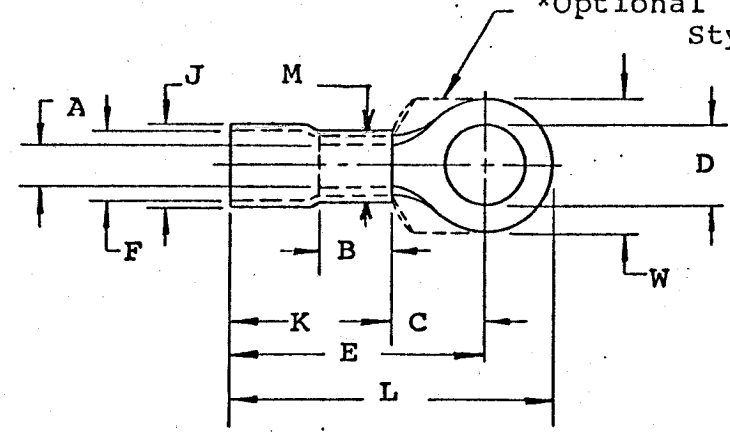

"M" = .630" Maximum

- 10 - .198
- 14 - .265
- 56 - .328
- 38 - .390
- 76 - .453
- 12 - .515
- 58 - .656
- 34 - .781

Part Number	"W"	"C" Min.	"E" Max.	"K" Max.	"L" Max.	"A" Min. Avg.	"F" (MWID)	Stock Thickness	"J" Max.	"B" Min.	Available Stud Size
G-674-X	.893 .867	.693	1.803	1.065	2.234	.355	.650	.075	.760	.490	14, 56, 38, 76 12, 58
G-675-X	.643 .617	.693	1.803	1.065	2.110	.355	.650	.075	.760	.490	10, 14, 56, 38 76
G-676-X	.893 .867	.990	2.090	1.065	2.527	.355	.650	.075	.760	.490	14, 56, 38, 76 12, 58
G-677-X	1.268 1.242	.990	2.090	1.065	2.685	.355	.650	.075	.760	.490	14, 56, 38, 76 12, 58, 34

NOTE: (MWID) denotes maximum wire insulation diameter.



TITLE: CUSTOMER DRAWING  
 #2 WIRE SIZE (G)  
 RING TONGUE TERMINAL

DIMENSIONAL TOLERANCE UNLESS OTHERWISE SPECIFIED		
FRAC.	DEC.	ANG.
±	±	±

REVISION	SCALE: _____	DATE
	DRWN. BY: JTK	1-21-70
	CHKD. BY:	
	APPRD. BY:	
	DRAWING NO.:	