



UR6511

Preliminary

LINEAR INTEGRATED CIRCUIT

2A DDR BUS TERMINATION REGULATOR

DESCRIPTION

The UR6511 is a linear regulator providing up to 2A transient current sourcing and sinking capability for DDR bus terminator applications while regulating an output voltage to within 20mV. It contains a high speed operational amplifier which provides fast load transient response and only requires 10uF of ceramic output capacitance.

The UR6511 output termination voltage tracks the reference voltage applied at V_{REF} pin. A resistor divider connected to V_{IN}, GND and V_{REF} pins is used to force the reference voltage to V_{REF} pin. Additional features include current limiting protection and thermal shutdown protection.

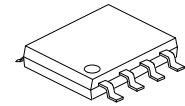

SOP-8

FEATURES

- *DDR1/ DDR2/DDR3/Low Power DDR3 termination voltage applications
- *Sink and Source Current: 2A
- *Low output voltage offset within 20mV
- *Adjustable output voltage by external resistors
- *Integrated power MOS devices
- *Suspend to RAM(STR) functionality
- *Current Limiting Protection
- *Thermal Shutdown Protection
- *Cost-effective and easy to use

ORDERING INFORMATION

Ordering Number		Package	Packing
Lead Free	Halogen Free		
UR6511L-S08-R	UR6511G-S08-R	SOP-8	Tape Reel

<p>UR6511G-S08-R</p> <ul style="list-style-type: none"> (1) Packing Type (2) Package Type (3) Green Package 	<ul style="list-style-type: none"> (1) R: Tape Reel (2) S08: SOP-8 (3) G: Halogen Free and Lead Free, L: Lead Free
--	---

MARKING

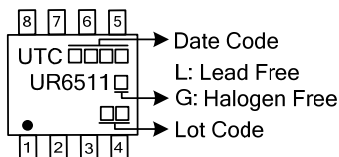

■ PIN CONFIGURATIONS

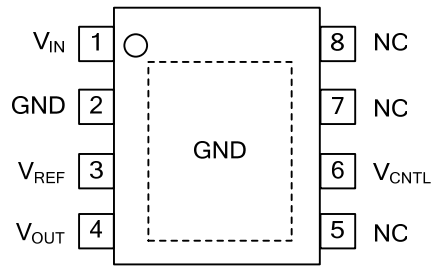

■ PIN DESCRIPTION

No.	PIN NAME	PIN TYPE	PIN DESCRIPTION
1	V_{IN}	I	Power supply pin for the V_{OUT} output
2	GND	O	Ground pin
3	V_{REF}	I	Reference voltage input and active-low shutdown control pin
4	V_{OUT}	O	Output voltage pin
5, 7, 8	NC		
6	V_{CNTRL}	I	Power supply pin for the internal control circuits

■ BLOCK DIAGRAM

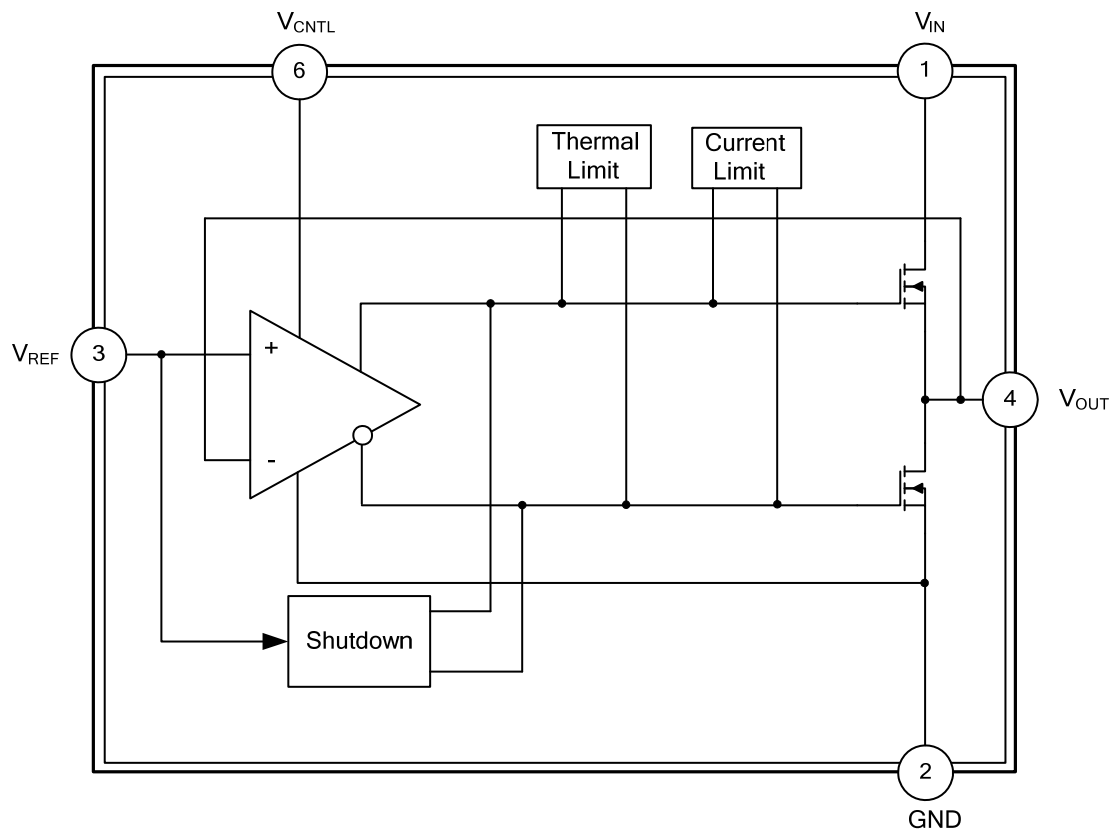

■ ABSOLUTE MAXIMUM RATING (unless otherwise specified)

PARAMETER	SYMBOL	RATINGS	UNIT
V _{CNTL} Control Voltage	V _{CNTL}	7	V
V _{IN} Supply Voltage	V _{IN}	7	V
Power Dissipation (T _A =25°C)	P _D	1.33	W
Junction Temperature	T _J	150	°C
Storage Temperature	T _{STG}	-65 ~ +150	°C

Note: Absolute maximum ratings are those values beyond which the device could be permanently damaged. Absolute maximum ratings are stress ratings only and functional device operation is not implied.

■ THERMAL DATA

PARAMETER	SYMBOL	RATINGS	UNIT
Junction to Ambient	θ _{JA}	75	°C/W
Junction to Case	θ _{JC}	20	°C/W

■ RECOMMENDED OPERATING CONDITIONS (Note 1)

PARAMETER	SYMBOL	RATINGS	UNIT
V _{CNTL} Control Voltage	V _{CNTL}	3.0 ~ 5.5	V
V _{IN} Supply Voltage	V _{IN}	1.0 ~ 5.5	V
Junction Temperature	T _J	-40 ~ +125	°C
Ambient Temperature	T _A	-40 ~ +85	°C

Note: All voltage values are with respect to the network ground terminal unless otherwise noted.

■ ELECTRICAL CHARACTERISTICS (T_A=25°C, unless otherwise specified)

(V_{IN}=2.5V/1.8V/1.5V, V_{CNTL}=3.3V/5V, V_{REF}=1.25V/0.9V/0.75V, C_{OUT} = 10μF (Ceramic))

PARAMETER	SYMBOL	TEST CONDITIONS	MIN	TYP	MAX	UNIT
INPUT CURRENT						
Operation Current of V _{CNTL}	I _{CNTL}	I _{OUT} =0A, V _{CNTL} =5V		0.7	1.5	mA
Standby Current	I _{STB}	V _{REF} <0.15V, V _{CNTL} =5V		30	50	μA
OUTPUT VOLTAGE (DDR/DDR II/DDR III)						
Output Voltage Offset (V _{REF} -V _{OUT})	V _{OS}	I _{OUT} =0A	-10		10	mV
Load Regulation	ΔV _{LOAD}	I _{OUT} =±2A	-20		20	mV
PROTECTION						
Current Limit	I _{LIMIT}		2			A
Thermal Shutdown Temperature	T _{SD}	V _{CNTL} =3.3V~5V		165		°C
Thermal Shutdown Hysteresis	ΔT _{SD}	V _{CNTL} =3.3V~5V		30		°C
V_{REF} Shutdown						
Shutdown Threshold	V _{IH}	Enable	0.4			V
	V _{IL}	Shutdown			0.15	V

■ TYPICAL APPLICATIONS CIRCUITS

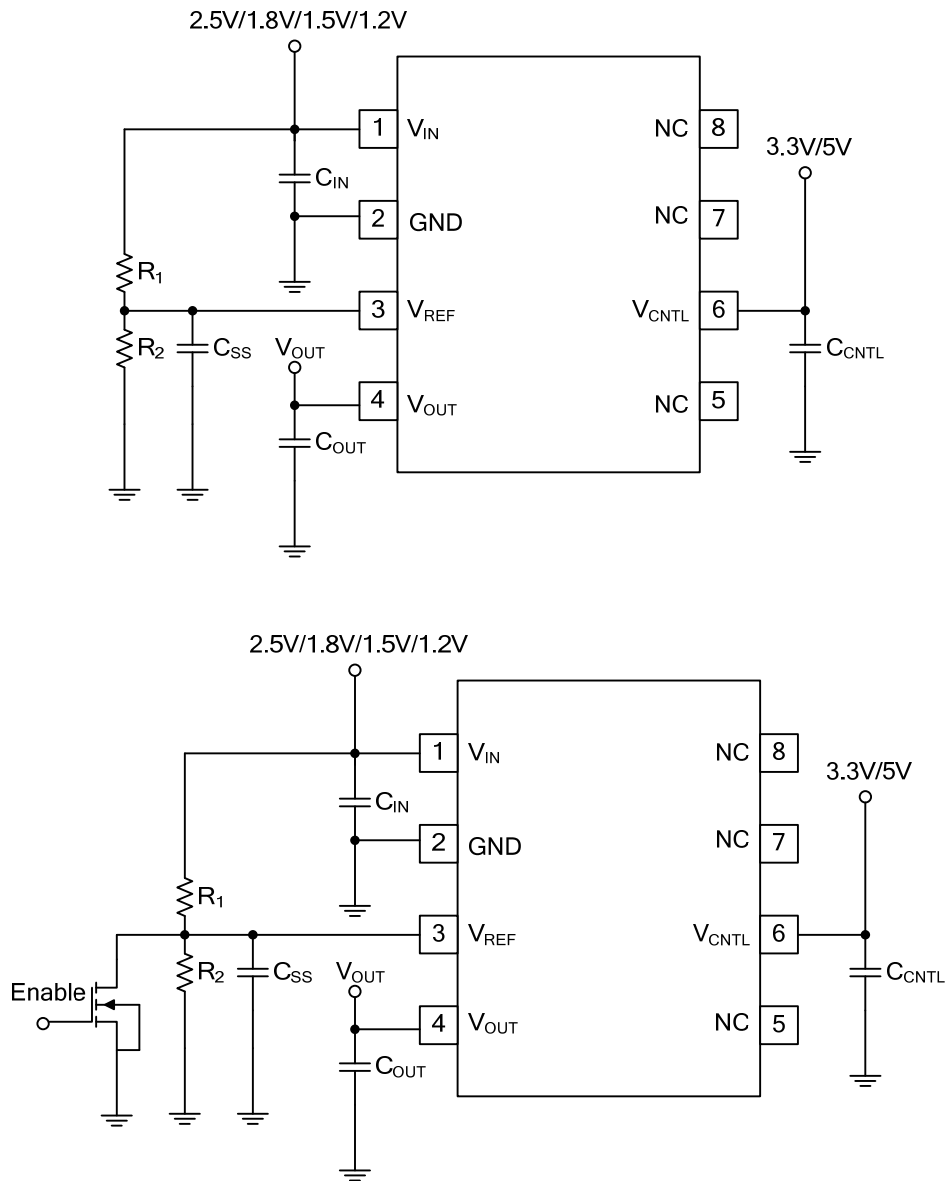

$R_1=R_2=1K\Omega\sim 5K\Omega$, $C_{OUT}=10\mu F$ (Ceramic)under the worst case testing condition

$C_{SS}=0.1\mu F$ to $1\mu F$, $C_{IN}=10\mu F$ (Low ESR), $C_{CNTRL}=0.1\mu F$

$$V_{REF} = \frac{R_2}{R_1 + R_2} V_{IN}(V), V_{OUT} \text{ track } V_{REF}$$

UTC assumes no responsibility for equipment failures that result from using products at values that exceed, even momentarily, rated values (such as maximum ratings, operating condition ranges, or other parameters) listed in products specifications of any and all UTC products described or contained herein. UTC products are not designed for use in life support appliances, devices or systems where malfunction of these products can be reasonably expected to result in personal injury. Reproduction in whole or in part is prohibited without the prior written consent of the copyright owner. UTC reserves the right to make changes to information published in this document, including without limitation specifications and product descriptions, at any time and without notice. This document supersedes and replaces all information supplied prior to the publication hereof.