

T H E R M O M E T R I C S
A C O M M I T M E N T T O E X C E L L E N C E

NTC Type KY2, KY3

Composite Thermistor



Description

Composite thermistor types KY2 and KY3 contain one PTC and two NTC thermistor elements connected inside a plastic sleeve and encapsulated in a brass probe housing. Primarily intended for automotive applications, where a constant sensor resistance is required over a "normal" range of engine temperatures to give a fixed temperature gauge reading.

Amphenol
Advanced Sensors

Type KY2, KY3 Specifications

Electrical KY2

Temperature °F (°C)	"Zero Power" Resistance
140 (60)	640Ω NOM
179.6 (82)	250Ω ± 8%
206.6 (97)	170Ω ± 8%
221 (105)	170Ω ± 8%
246.2 (119)	112Ω ± 8%

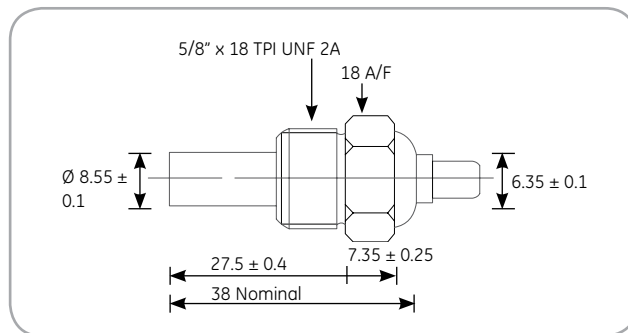

Dimensions

Electrical KY3

Temperature °F (°C)	"Power On"* Resistance
140 (60)	119Ω ± 20%
185 (85)	73.5Ω ± 12%
206.6 (97)	73.5Ω ± 12%
246.2 (119)	38.0Ω ± 8%

Options

- Other resistance-temperature characteristics
- Alternative housings

* "POWER ON" resistance values measured with the thermistor assembled in a brass probe body. The probe is immersed in circulating oil (light engine type) up to the bottom of the hexagonal head and self-heated using the following circuit:

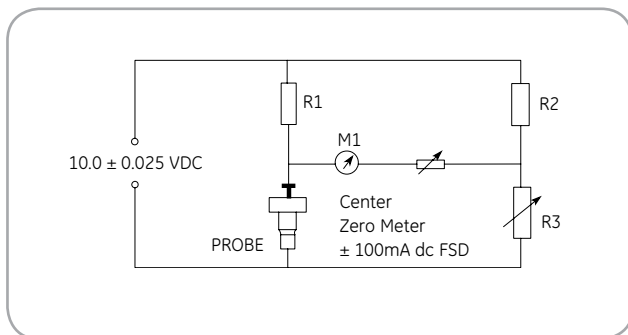

R1, R2 = 58.8Ω approximate (matched within 0.1% at room temperature)

R3 : Decade resistance box adjusted to give null reading on meter M1