



3Northway Lane North Latham, New York 12110.

Tollfree:1.800.984.5337

Phone:1.518.956.2980

Fax:1.518.785.4725

Http://www.marktechopto.com

SPECIFICATION

PART NO. : MT1195-RG-A

4.7mm CYLINDRIC LED LAMP



Description

This red lamp is made with GaP/GaP chip and red diffused epoxy resin.

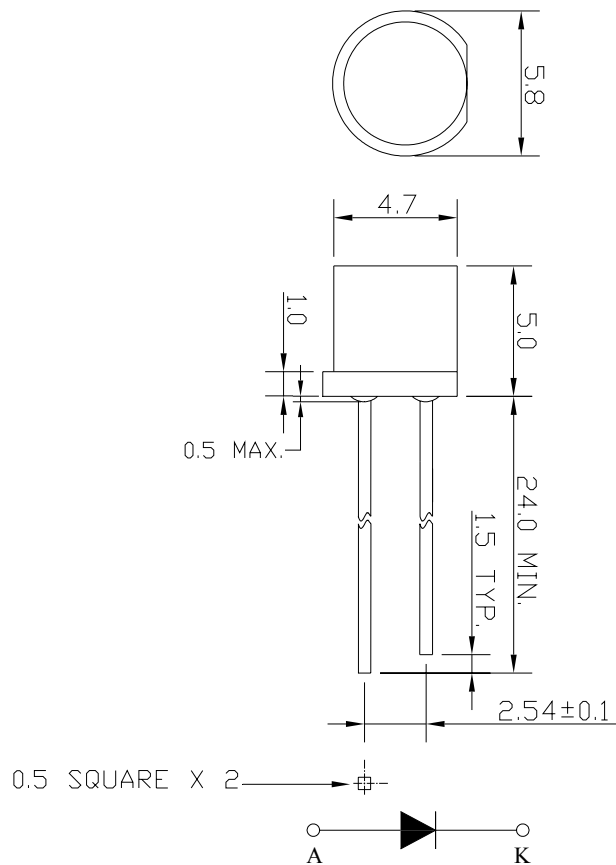

Notes:

1. All dimensions are in mm.
2. Tolerance is ± 0.25mm unless otherwise noted.

Description

Part No.	LED Chip		Lens Color
	Material	Emitting Color	
MT1195-RG-A	GaP/GaP	Red	Red diffused

Absolute Maximum Ratings at Ta=25

Parameter	Symbol	Rating	Unit
Power Dissipation	PD	90	mW
Reverse Voltage	VR	5	V
D.C. Forward Current	If	30	mA
Reverse (Leakage) Current	Ir	100	μ A
Peak Current(1/10Duty Cycle,0.1ms Pulse Width.)	If(Peak)	100	mA
Operating Temperature Range	Topr.	-40 to +95	
Storage Temperature Range	Tstg.	-40 to +100	
Soldering Temperature(1.6mm from body)	Tsol	Dip Soldering : 260 for 5 sec. Hand Soldering : 350 for 3 sec.	

Electrical and Optical Characteristics:

Parameter	Symbol	Condition	Min.	Typ.	Max.	Unit
Luminous Intensity	Iv	If=20mA	0.42	1.0	2.0	mcd
Forward Voltage	Vf	If=20mA		2.1	3.0	V
Peak Wavelength	λ_p	If=20mA		700		nm
Dominant Wavelength	λ_d	If=20mA		650		nm
Reverse (Leakage) Current	Ir	VR=5V			100	μ A
Viewing Angle	2 1/2	If=20mA		110		deg
Spectrum Line Halfwidth	$\Delta\lambda$	If=20mA		100		nm

Notes:1. The datas tested by IS tester.

2. Customer's special requirements are also welcome.

Typical Electrical / Optical Characteristics Curves :

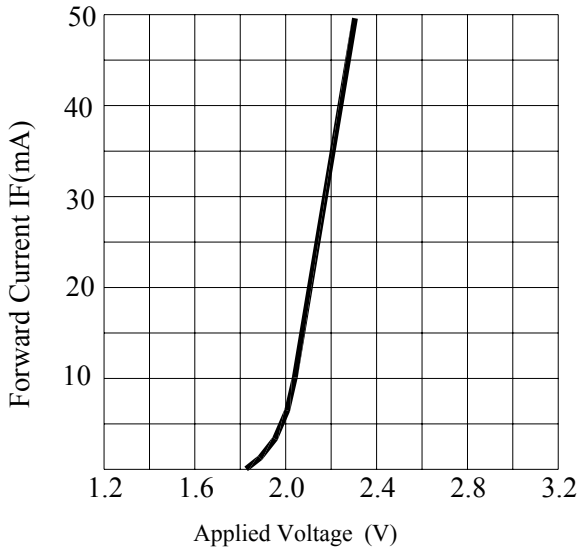

FORWARD CURRENT VS. APPLIED VOLTAGE

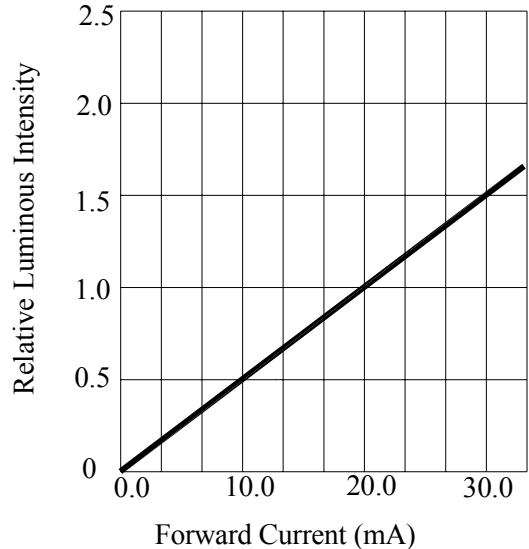

FORWARD CURRENT VS. LUMINOUS INTENSITY

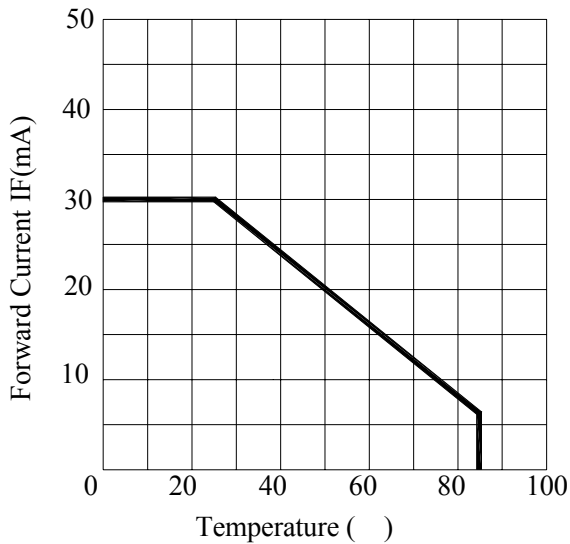

FORWARD CURRENT VS. AMBIENT TEMPERATURE

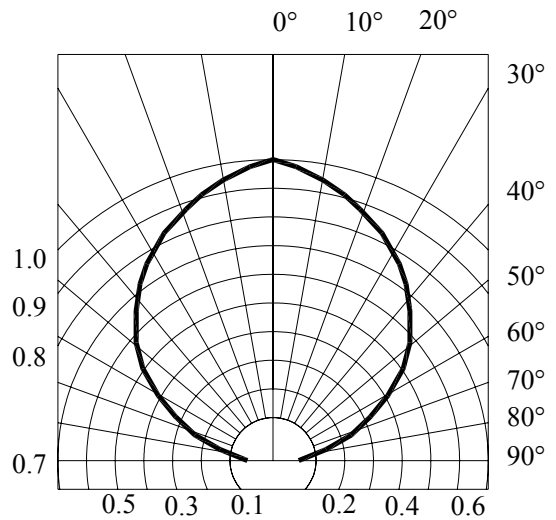

RADIATION DIAGRAM

Specifications for Bin Grading:

Iv(mcd)		
BIN	MIN.	MAX.
10	0.429	0.622
12	0.622	0.909
14	0.909	1.35
16	1.35	2.00

Specifications for Vf Group:

Vf(V)		
Group	MIN.	MAX.
V1	1.6	1.8
V2	1.8	2.0
V3	2.0	2.2
V4	2.2	2.4
V5	2.4	2.6
V6	2.6	2.8
V7	2.8	3.0

***Majority VF bins are highlighted in Yellow.**

Precautions:

TAKE NOTE OF THE FOLLOWING IN USE OF LED

1. Temperature in use

Since the light generated inside the LED needs to be emitted to outside efficiently, a resin with high light transparency is used; therefore, additives to improve the heat resistance or moisture resistance (silica gel, etc) which are used for semiconductor products such as transistors cannot be added to the resin.

Consequently, the heat resistant ability of the resin used for LED is usually low; therefore, please be careful on the following during use.

Avoid applying external force, stress, and excessive vibration to the resins and terminals at high temperature. The glass transition temperature of epoxy resin used for the LED is approximately 120-130 .

At a temperature exceeding this limit, the coefficient of linear expansion of the resin doubles or more compared to that at normal temperature and the resin is softened.

If external force or stress is applied at that time, it may cause a wire rupture.

2. Soldering

Please be careful on the following at soldering.

After soldering, avoid applying external force, stress, and excessive vibration until the products go to cooling process (normal temperature), <Same for products with terminal leads>

(1) Soldering measurements:

Distance between melted solder side to bottom of resin shall be 1.6mm or longer.

(2) Solder dip: Preheat: 90 max. (Backside of PCB), Within 60 seconds

Solder bath: 260±5 (Solder temperature), Within 5 seconds

(3) Soldering iron : 350 max. (Temperature of soldering iron tip), Within 3 seconds

3. Insertion

Pitch of the LED leads and pitch of mounting holes need to be same

4. Others

Since the heat resistant ability of the LED resin is low, SMD components are used on the same PCB, please mount the LED after adhesive baking process for SMD components. In case adhesive baking is done after LED lamp insertion due to a production process reason, make sure not to apply external force, stress, and excessive vibration to the LED and follow the conditions below.

Baking temperature: 120 max. Baking time: Within 60 seconds

If soldering is done sequentially after the adhesive baking, please perform the soldering after cooling down the LED to normal temperature.