

TMBF302 THRU TMBF310

SINGLE PHASE 3.0AMPS. GLASS PASSIVATED BRIDGE RECTIFIERS



FEATURE

- . Glass passivated junction.
- . Ideal for printed circuit board.
- . Reliable low cost construction utilizing molded plastic technique.
- . High surge current capability.
- . High temperature soldering guaranteed: 260°C/10 seconds at terminals.

MECHANICAL DATA

- . Case Material: "Green" Molding compound, UL flammability classification rating 94V-0, "Free halogen"
- . Moisture sensitivity level: level 2a, per J-STD-020
- . Polarity: Polarity as marked on the body
- . Weight: 0.204g (approximately)

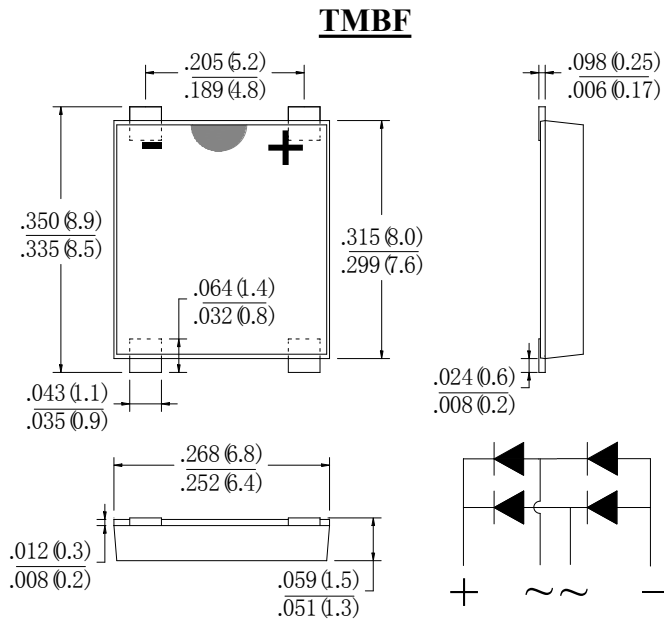

Dimensions in inches and (millimeters)

MAXIMUM RATINGS AND ELECTRICAL CHARACTERISTICS

Ratings at 25°C ambient temperature unless otherwise specified.
Single phase, half wave, 60Hz, resistive or inductive load.
For capacitive load, derate current by 20%

Type Number	SYM BOL	TMBF 302	TMBF 304	TMBF 306	TMBF 308	TMBF 310	units
Maximum Recurrent Peak Reverse Voltage	V_{RRM}	200	400	600	800	1000	V
Maximum RMS Voltage	V_{RMS}	160	320	420	560	700	V
Maximum DC blocking Voltage	V_{DC}	200	400	600	800	1000	V
Maximum Average Forward rectified Current @ $T_A=40^\circ\text{C}$	$I_{F(AV)}$	3.0					A
Peak Forward Surge Current 8.3ms single half sine-wave superimposed on rate load (JEDEC method)	I_{FSM}	100					A
Maximum Instantaneous Forward Voltage @ $I_F=1.5\text{A DC}$ @ $I_F=3.0\text{A DC}$	V_F	1.0 1.1					V
Maximum DC Reverse Current @ $T_J=25^\circ\text{C}$ at rated DC blocking voltage @ $T_J=125^\circ\text{C}$	I_R	5.0 500.0					μA
I^2t Rating for Fusing ($t < 8.3\text{ms}$)	Pt	41.5					A^2Sec
Typical Junction Capacitance Per Leg (Note1)	C_J	35					pF
Typical Thermal Resistance (Note2)	R_{JA}	15					$^\circ\text{C/W}$
	R_{JC}	7					
Storage Temperature	T_{STG}	-55 to +150					$^\circ\text{C}$
Operating Junction Temperature	T_J	-55 to +150					$^\circ\text{C}$

Note:

1. Measured at 1.0 MHz and applied reverse voltage of 4.0Vdc
2. Thermal resistance from Junction to case, lead and ambient in accordance with JESD-51.
Unit mounted on 15mm*12mm*1.6mm AL pad attach 195mm*195mm*10mm steel plate

RATING AND CHARACTERISTIC CURVES (TMBF302 THRU TMBF310)

FIG.1-TYPICAL FORWARD CURRENT DERATING CURVE

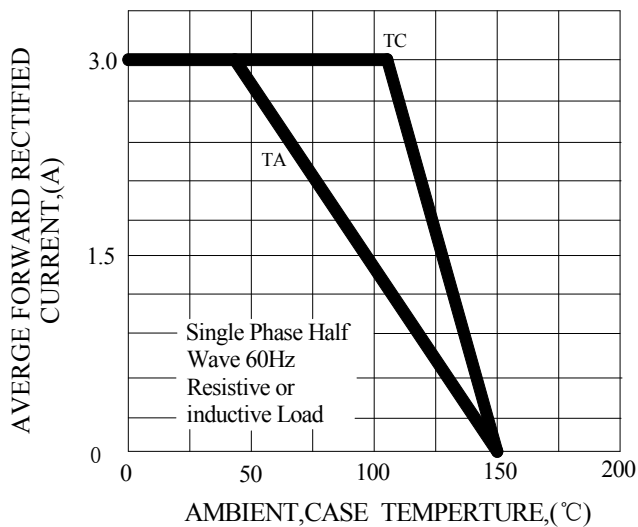

FIG.2-TYPICAL INSTANTANEOUS FORWARD CHARACTERISTICS

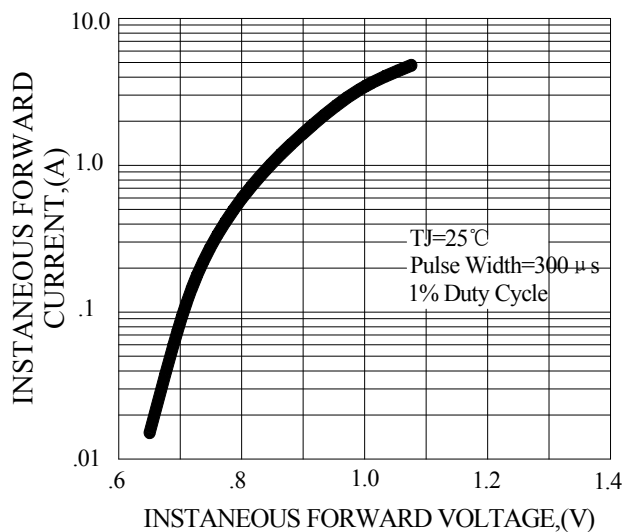

FIG.3-MAXIMUN NON-REPETITIVE FORWARD SURGE CURRENT

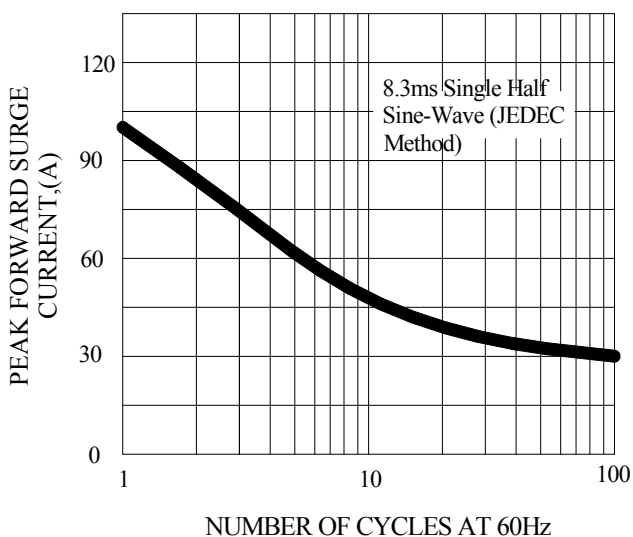

FIG.4-TYPICAL REVERSE CHARACTERISTICS

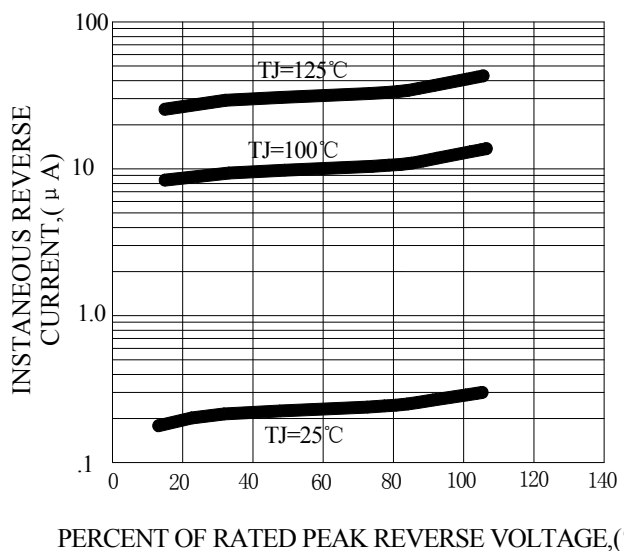

FIG.5-TYPICAL JUNCTION CAPAOTANCE

