

M-G550-PR

IMU (Inertial Measurement Unit) RS422 INTERFACE

■ GENERAL DESCRIPTION

The M-G550-PR is a small form-factor inertial measurement unit (IMU) with 6 degrees of freedom: triaxial angular rates and linear accelerations, and provides high-stability and high-precision measurement capabilities with the use of high-precision compensation technology. A variety of calibration parameters are stored in a memory of the IMU, and are automatically reflected in the measurement data being sent to the application after the power of the IMU is turned on. With a RS-422 interface supported for host communication, the M-G550-PR reduces technical barriers for users to introduce inertial measurement and minimizes design resources to implement inertial movement analysis and control applications. This unit is packaged in a water-proof and dust-proof metallic case. It is suitable to use for industrial and heavy duty applications.

The features of the IMU such as high stability, high precision, and small size make it easy to create and differentiate applications in various fields of industrial systems.

■ FEATURES

Item	Specification	Note
Sensor		
Integrated sensor	SEIKO EPSON inertial measurement sensor (M-G350-PD11) Low-Noise, High-stability Gyro Bias Instability: 6 deg/hr Angular Random Walk : 0.2 deg/√hr Initial Bias Error : 0.5 deg/s (1σ) 6 Degree Of Freedom Triple Gyroscope : ±300 deg/s Tri-Axis Accelerometer : ±3 G 16bit data resolution Calibrated Stability (Bias, Scale Factor, Axial alignment)	
Sampling rate	1000sps (Max)	Selectable
Interface		
Protocol	RS-422 (TX/RX Pair, Duplex transmission)	
Bit rate	460.8Kbps	
Cable Length	250m Max.	(Target Value)
Terminator	Included (100 ohms typ.)	
General specification		
Voltage supply	9 to 30 V	
Power consumption	TBD mA (Typ. Vin = 12V)	
Operating temperature range	-25 to +70°C	

External dimension		
Outer packaging	Overall metallic shield case	
Size	52 x 52 x 26mm (Not including projection.)	
Weight	85g	
Interface connector	M12, 8pin-male, water-proof	
Water-proof, Dust-proof:	Corresponds with IP67	
Regulation		
EU	CE marking (EN61326/RoHS Directive)	
USA	FCC part15B	

APPLICATIONS

- Motion and Vibration Measurement
- Platform Stabilization
- Attitude Detection for Unmanned Systems
- Vibration Control and Stabilization

OUTLINE DIMENSION

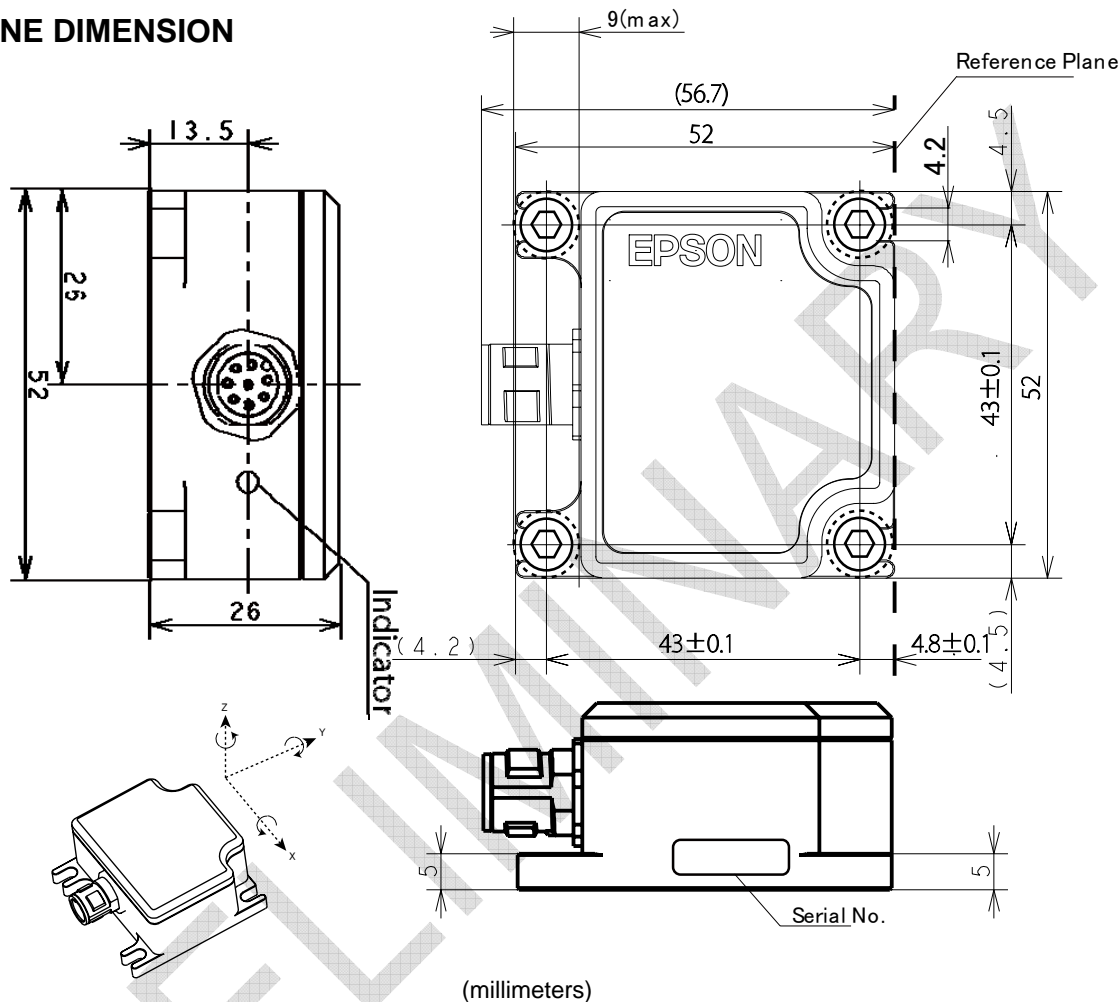

NOTICE:

No part of this material may be reproduced or duplicated in any form or by any means without the written permission of Seiko Epson. Seiko Epson reserves the right to make changes to this material without notice. Seiko Epson does not assume any liability of any kind arising out of any inaccuracies contained in this material or due to its application or use in any product or circuit and, further, there is no representation that this material is applicable to products requiring high level reliability, such as, medical products. Moreover, no license to any intellectual property rights is granted by implication or otherwise, and there is no representation or warranty that anything made in accordance with this material will be free from any patent or copyright infringement of a third party. This material or portions thereof may contain technology or the subject relating to strategic products under the control of the Foreign Exchange and Foreign Trade Law of Japan and may require an export license from the Ministry of Economy, Trade and Industry or other approval from another government agency.

All brands or product names mentioned herein are trademarks and/or registered trademarks of their respective companies.

©Seiko Epson Corporation 2013, All rights reserved

SEIKO EPSON CORPORATION

Sensing System Operations Division

421-8 Hino, Hino-shi, Tokyo 191-8501, JAPAN
 Phone: +81-42-587-8291 FAX: +81-42-587-5117

Document code: 412528600
 First issue April, 2013 in Japan
 Rev.20130425