

**Description** This ceiling mount bracket is to be used when mounting home cinema projectors to the ceiling.

<b>Specifications</b>	Vertical correction angle	+5°, -15°
	Horizontal slant correction angle	±10°
	Horizontal turn correction angle	±5°
	Dimensions (W × H × D)	306 × 89.5 × 174 mm (12-1/16" × 3-17/32" × 6-7/8")
	Weight	Approx. 1.3 kg* (2.9 lbs*)
	Applicable projectors	PT-AE8000/AT6000/AE7000/AT5000/AR100/AH1000/LZ370

\* Average value. May differ depending on models.

<b>Parts</b>	Attachment plate	..... 1	Wire rope for ceiling mount bracket	..... 1
	Projector mount bracket	..... 1	Flat wire clip for ceiling mount bracket	..... 2
	Washer-fitted screws (M4 × 10)	..... 4	Clamp tube for ceiling mount bracket	..... 2
			Projector drop-prevention kit	..... 1

**Caution:**

- All mounting work must be done by a qualified technician.
- Ensure that the mounting (ceiling) area has sufficient strength.
- Read the enclosed mounting instructions carefully before starting the mounting procedure.
- When the system is no longer to be used, have a qualified technician promptly remove and dispose of it.
- Do not use a power screwdriver or impact screwdriver to tighten screws. A torque screwdriver or similar tool should be used.

**Dimensions**

Illustration shows the ET-PKA110S attached to a projector.

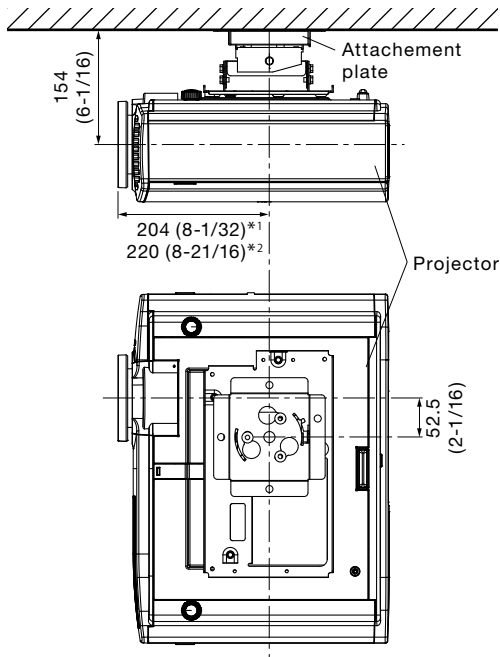

\*1 PT-AE8000/AT6000/AE7000/AT5000  
\*2 PT-AR100/AH1000/LZ370

Attachment plate

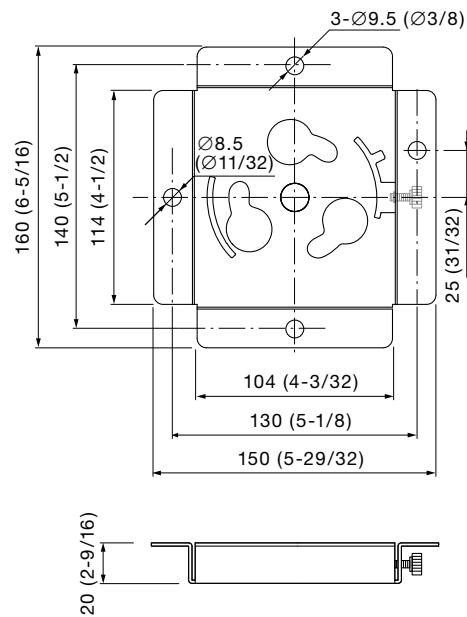

unit : mm (inch)

NOTE: This illustration is not drawn to scale.

Weights and dimensions shown are approximate. Specifications subject to change without notice.