

# CBT-QFE DIRECT MOUNT, SOLDERLESS SOCKET FOR BURN-IN AND TEST APPLICATIONS

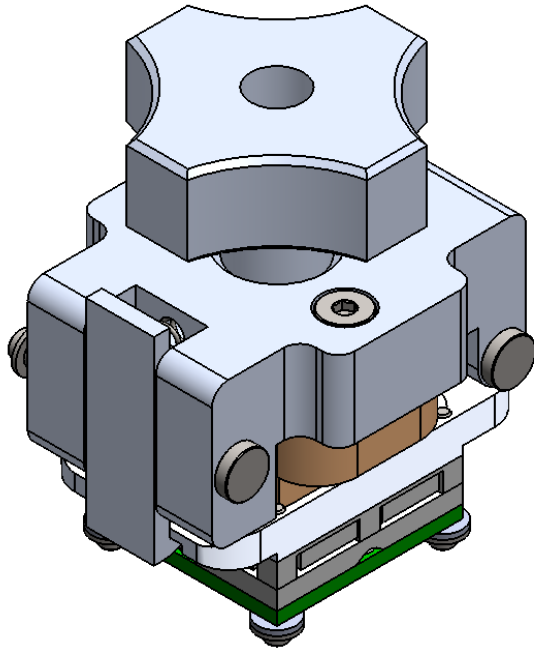

## Features

- Wide temperature range (-55C to +180C).
- High current capability (up to 8A).
- Excellent signal integrity at high frequencies.
- Low and stable contact resistance for reliable production yield.
- Highly compliant to accommodate wide co-planarity variations.
- Automated probe manufacturing enables low cost and short lead time.

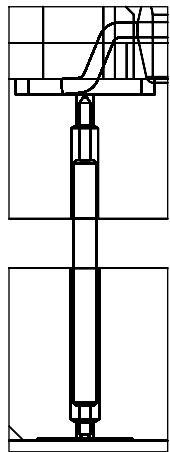

**DETAIL J**  
SCALE 10 : 1

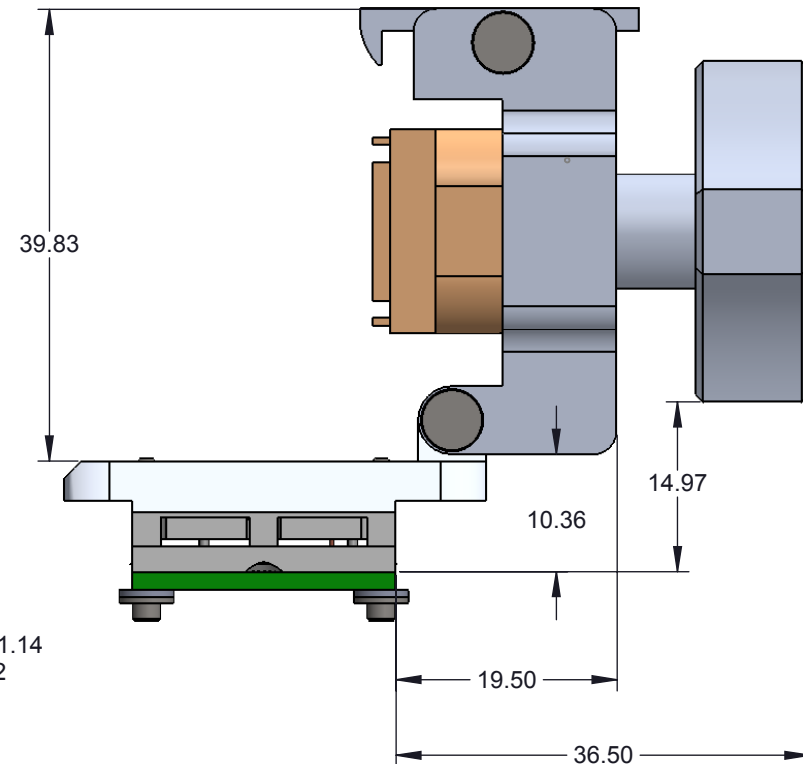
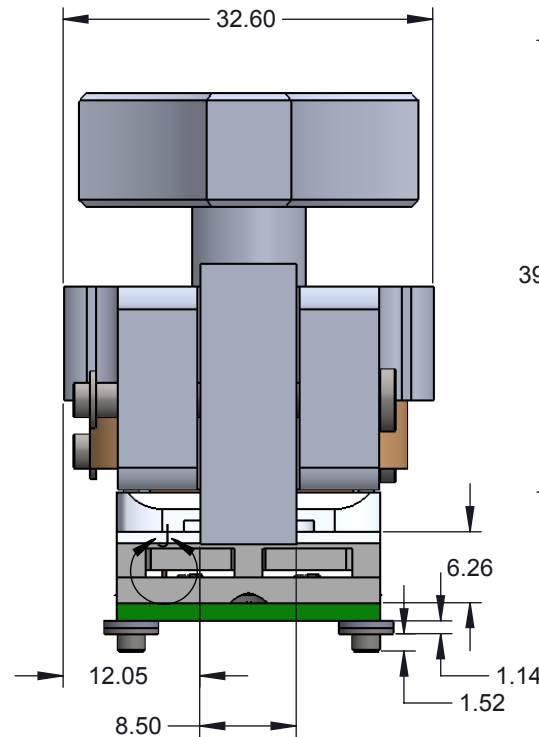

**Description: SS-QFE100SE 0.5mm Pitch (clam shell spring pin socket)**

Primary dimension units are millimeters, Secondary dimension units are [inches].

Tolerances: Hole diameters  $\pm 0.03\text{mm}$  [ $\pm 0.001''$ ], Pitches (from true position)  $\pm 0.025\text{mm}$  [ $\pm 0.001''$ ], substrate thickness tolerance  $\pm 10\%$ , all other tolerances  $\pm 0.13\text{mm}$  [ $\pm 0.005''$ ] unless stated otherwise. Materials and specifications are subject to change without notice.

### SS-QFE100SE-02 Specification



Ironwood Electronics, Inc.  
Tele: (800) 404-0204  
www.ironwoodelectronics.com

Material:  
Finish:  
Weight: 66.95

STATUS: Released

DRAWN BY: V. Panavala

FILE: SS-QFE100SE-02

SHEET: 1 OF 5

SCALE: 3:2

DATE: 7/25/2012

REV. A

**\*Note: QFE pattern is not symmetrical with respect to the mounting holes.**

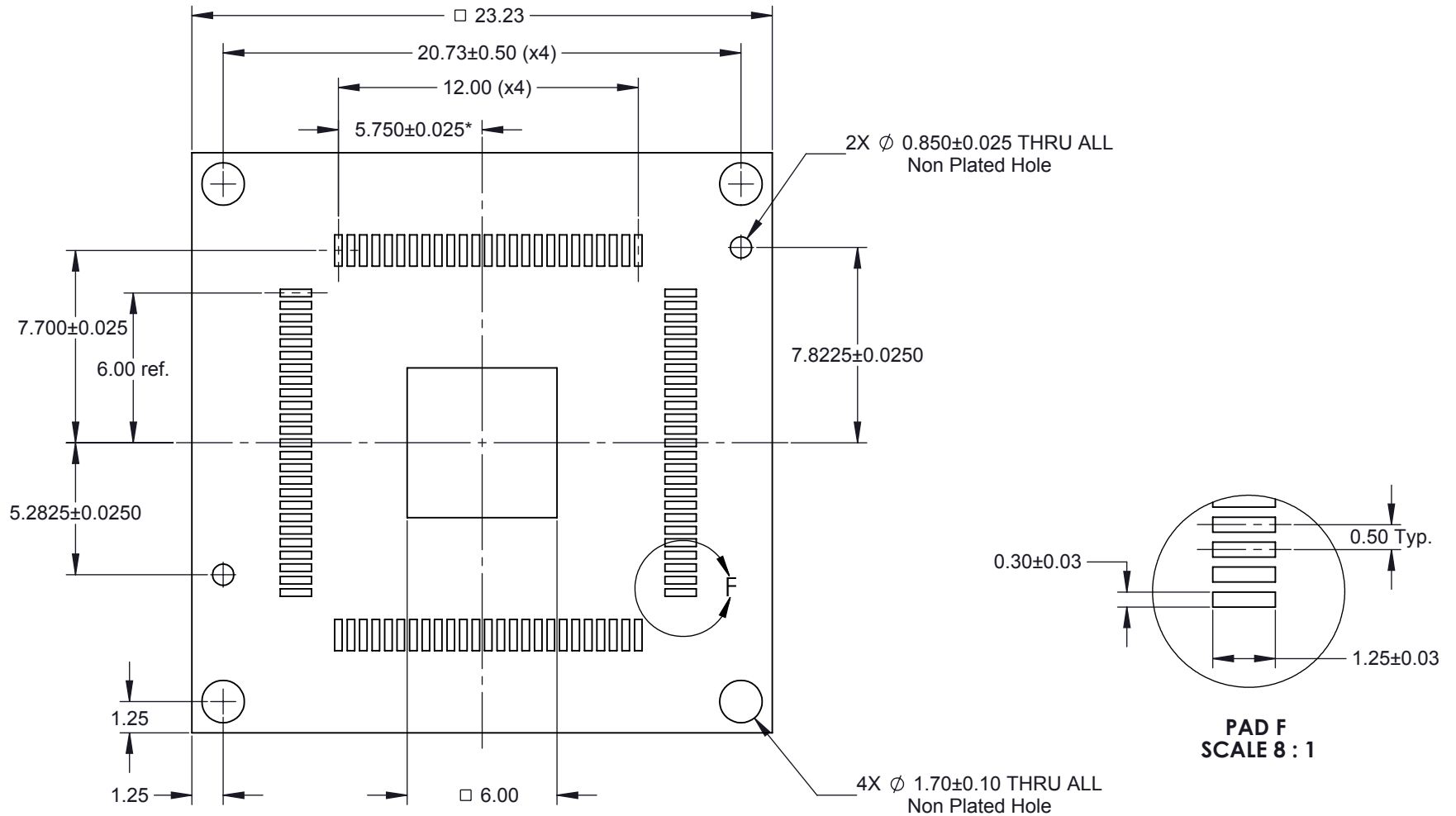

Target PCB Recommendations

Total thickness: 1.6mm min.

Plating: Gold or Solder finish

PCB Pad height: same or higher than solder mask

**Description: Recommended PCB layout**

Primary dimension units are millimeters, Secondary dimension units are [inches], Weight is in grams.

Tolerances: Hole diameters  $\pm 0.03\text{mm}$  [ $\pm 0.001''$ ], Pitches (from true position)  $\pm 0.025\text{mm}$  [ $\pm 0.001''$ ], substrate thickness tolerance  $\pm 10\%$ , all other tolerances  $\pm 0.13\text{mm}$  [ $\pm 0.005''$ ] unless stated otherwise. Materials and specifications are subject to change without notice.

 <p><b>SS-QFE100SE-02 Specification</b> Ironwood Electronics, Inc. Tele: (800) 404-0204 www.ironwoodelectronics.com</p>	Material:	STATUS: Released	SHEET: 2 OF 5	REV. A
	Finish:	DRAWN BY: V. Panavala	SCALE: 4:1	
	Weight: 66.95	FILE: SS-QFE100SE-02	DATE: 7/25/2012	

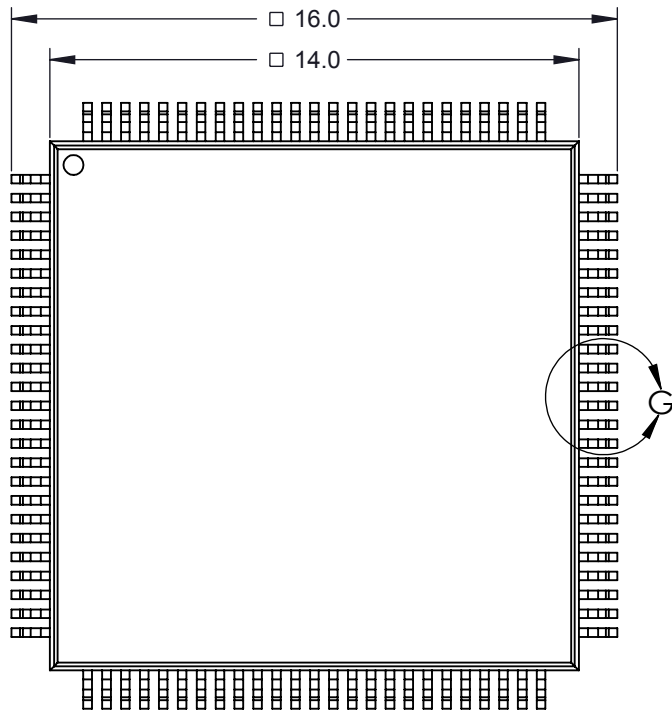

Top view

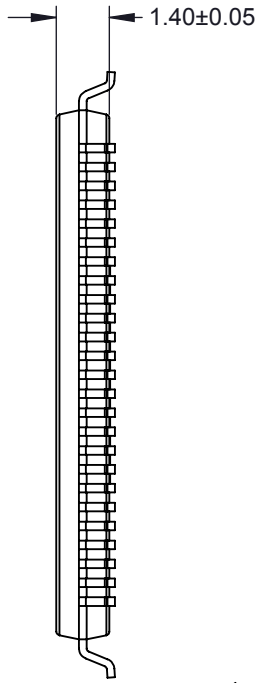

Side view

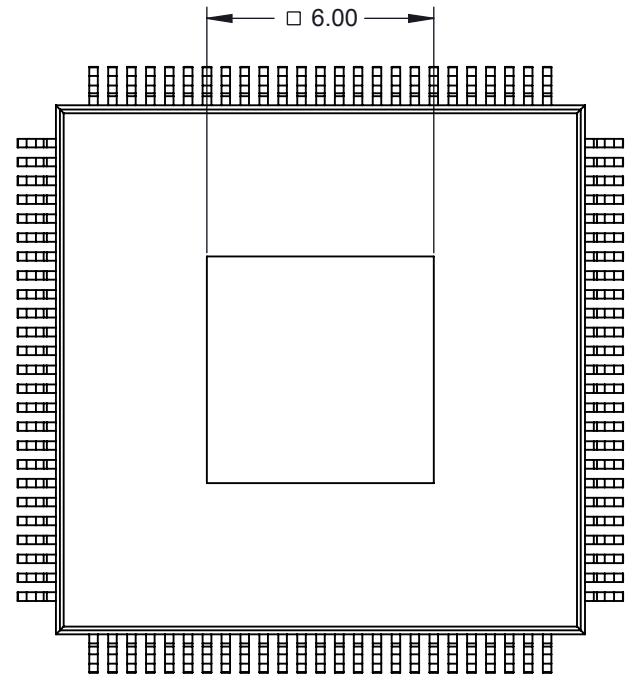

Bottom View

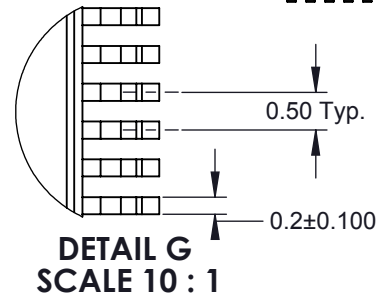
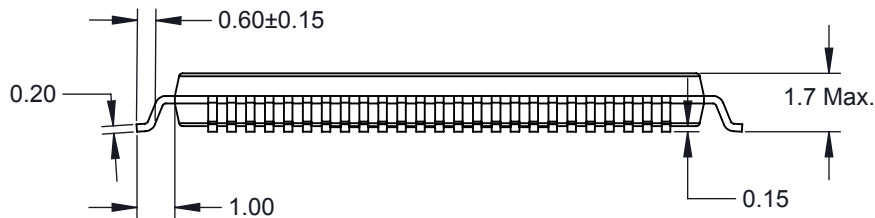

**Ironwood Package codes accommodated**

Pkg. Code	Pins	Pitch	Body Size	Tip to tip	foot length
QFE100SE	100	0.5mm	14mm x 14mm	16mm x 16mm	0.6mm

**Description: QFE100 IC**

Primary dimension units are millimeters, Secondary dimension units are [inches], Weight is in grams.

Tolerances: Hole diameters  $\pm 0.03\text{mm}$  [ $\pm 0.001"$ ], Pitches (from true position)  $\pm 0.025\text{mm}$  [ $\pm 0.001"$ ], substrate thickness tolerance  $\pm 10\%$ , all other tolerances  $\pm 0.13\text{mm}$  [ $\pm 0.005"$ ] unless stated otherwise. Materials and specifications are subject to change without notice.

**SS-QFE100SE-02 Specification**



Ironwood Electronics, Inc.  
 Tele: (800) 404-0204  
 www.ironwoodelectronics.com

Material:  
 Finish:  
 Weight: 66.95

STATUS: Released

DRAWN BY: V. Panavala

FILE: SS-QFE100SE-02

SHEET: 3 OF 5

SCALE: 5:1

DATE: 7/25/2012

REV. A

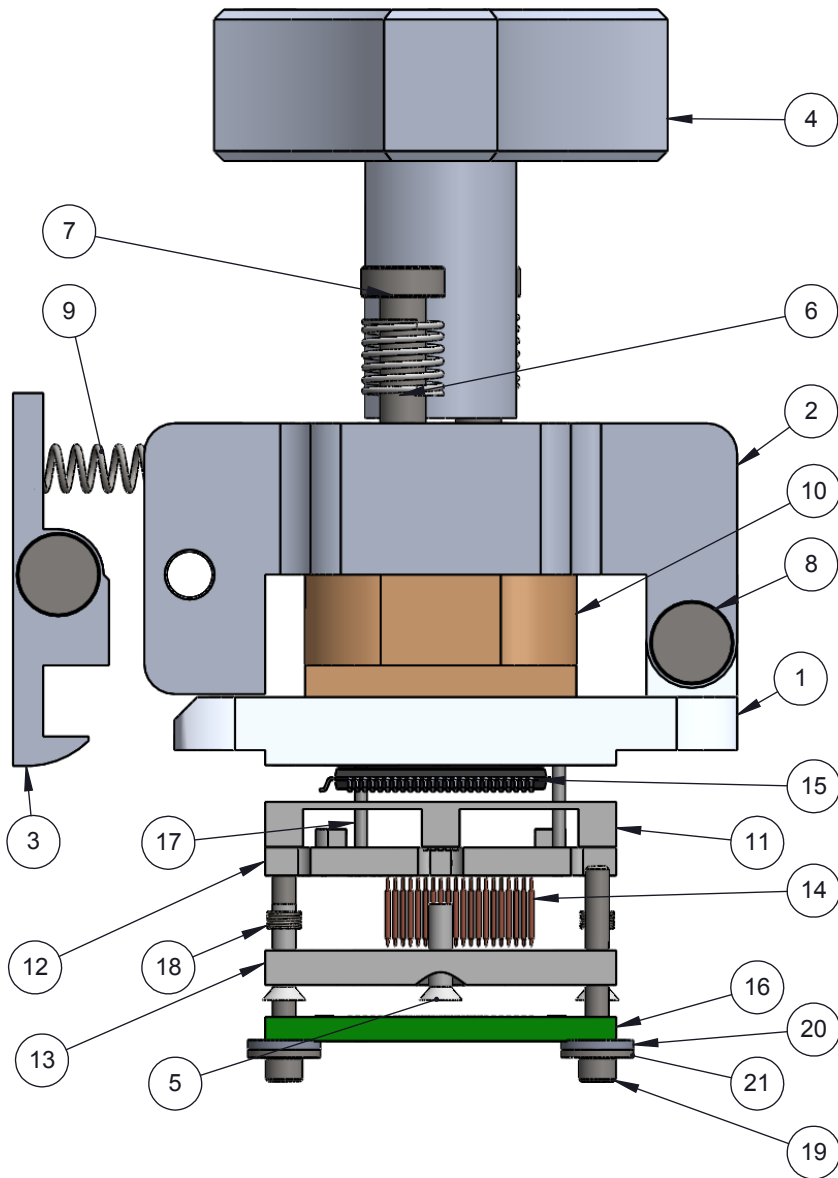

ITEM NO.	Description	Material
1	CBT Socket Base 18mm	7075-T6 Aluminum Alloy
2	Clam shell lid for 17mm IC	7075-T6 Aluminum Alloy
3	Clamshell Latch	7075-T6 Aluminum Alloy
4	M10 Compression Screw with hole	7075-T6 Aluminum Alloy
5	#0-80 x .25 LG, Flat Head Machine Screw	Stainless Steel (18-8)
6	Spring Clamshell lid assembly	Steel Music Wire
7	Screw, M3 x 12mm, Low Head Cap, SS	18-8 Stainless Steel
8	Hinge Pin and Snap Ring, 3mm OD, 25mm long, SS	Stainless Steel (ferritic)
9	Precision Compression Spring, Zinc-Plated Music Wire, 1/2" Length, .12" OD, .016" Wire	Zinc Plated Music Wire
10	QFE100 clashell socket compression Plate; 18mm	Ultem
11	IC guide QFE100SE clm skt	PEEK Ceramic filled
12	SS-QFE100SE top spring pin guide	PEEK Ceramic filled
13	SS-QFE100SE btm spring pin guide	PEEK Ceramic filled
14	Pogo pin 0.5mm QFE	Beryllium Copper, UNS C17300
15	QFE100SE chip	
16	QFE100SE PCB	Material <not specified>
17	Dowel pin, 1/32" x 5/16", SS	Chrome Stainless Steel
18	Floating Guide Spring	Alloy Steel (SS)
19	#0-80 x 0.5, SH Cap Screw	Material <not specified>
20	Washer, #0 x .025", Nylon	Nylon 6/6
21	316 SS General Purpose Flat Washer NO. 0 Screw Size, 3/16" OD, .01"-.03" Thick	AISI 316 Stainless Steel Sheet (SS)

#### Instructions:

- Drop the QFE package in the socket and make sure the QFE leads are sitting inside the guide slots of the top guide(item13)
- Turn the fluted knob screw(item 4) until it contacts the QFE chip.
- From that point screw needs four turns to get the desired compression. Or Turn the fluted knob( item 4) screw until the top guide( item 13) bottoms out on the bottom guide(item 14)

#### Description: Socket Spec

Primary dimension units are millimeters, Secondary dimension units are [inches], Weight is in grams.

Tolerances: Hole diameters  $\pm 0.03\text{mm}$  [ $\pm 0.001"$ ], Pitches (from true position)  $\pm 0.025\text{mm}$  [ $\pm 0.001"$ ], substrate thickness tolerance  $\pm 10\%$ , all other tolerances  $\pm 0.13\text{mm}$  [ $\pm 0.005"$ ] unless stated otherwise. Materials and specifications are subject to change without notice.

#### SS-QFE100SE-02 Specification



Ironwood Electronics, Inc.  
Tele: (800) 404-0204  
www.ironwoodelectronics.com

Material:  
Finish:  
Weight: 66.95

STATUS: Released

DRAWN BY: V. Panavala

FILE: SS-QFE100SE-02

SHEET: 4 OF 5

SCALE: 5:1

DATE: 7/25/2012

REV. A

Rev	Date	Initials	Description
A	7/25/12	VP	Original
B	8/14/2012	VP	Redesigned socket with new pogo pin

### Description:

Primary dimension units are millimeters, Secondary dimension units are [inches].

Tolerances: diameters  $\pm 0.03\text{mm}$  [ $\pm 0.001"$ ], PCB perimeters  $\pm 0.13\text{mm}$  [ $\pm 0.005"$ ], PCB thicknesses  $\pm 0.18\text{mm}$  [ $\pm 0.007"$ ], pitches (from true position)  $\pm 0.08\text{mm}$  [ $\pm 0.003"$ ], all other tolerances  $\pm 0.13\text{mm}$  [ $\pm 0.005"$ ] unless stated otherwise. Materials and specifications are subject to change without notice.

### SS-QFE100SE-02 Drawing

STATUS: Released

SHEET 5 OF 5

REV. A



Ironwood Electronics, Inc.  
 Tele: (800) 404-0204  
[www.ironwoodelectronics.com](http://www.ironwoodelectronics.com)

WEIGHT:  
 MATERIAL:  
 FINISH:

DRAWN BY: V. Panavala

SCALE: 5:1

File: SS-QFE100SE-02

DATE: 7/25/2012