

Ultra-Low Phase Noise 245.760 MHz SAW Clock

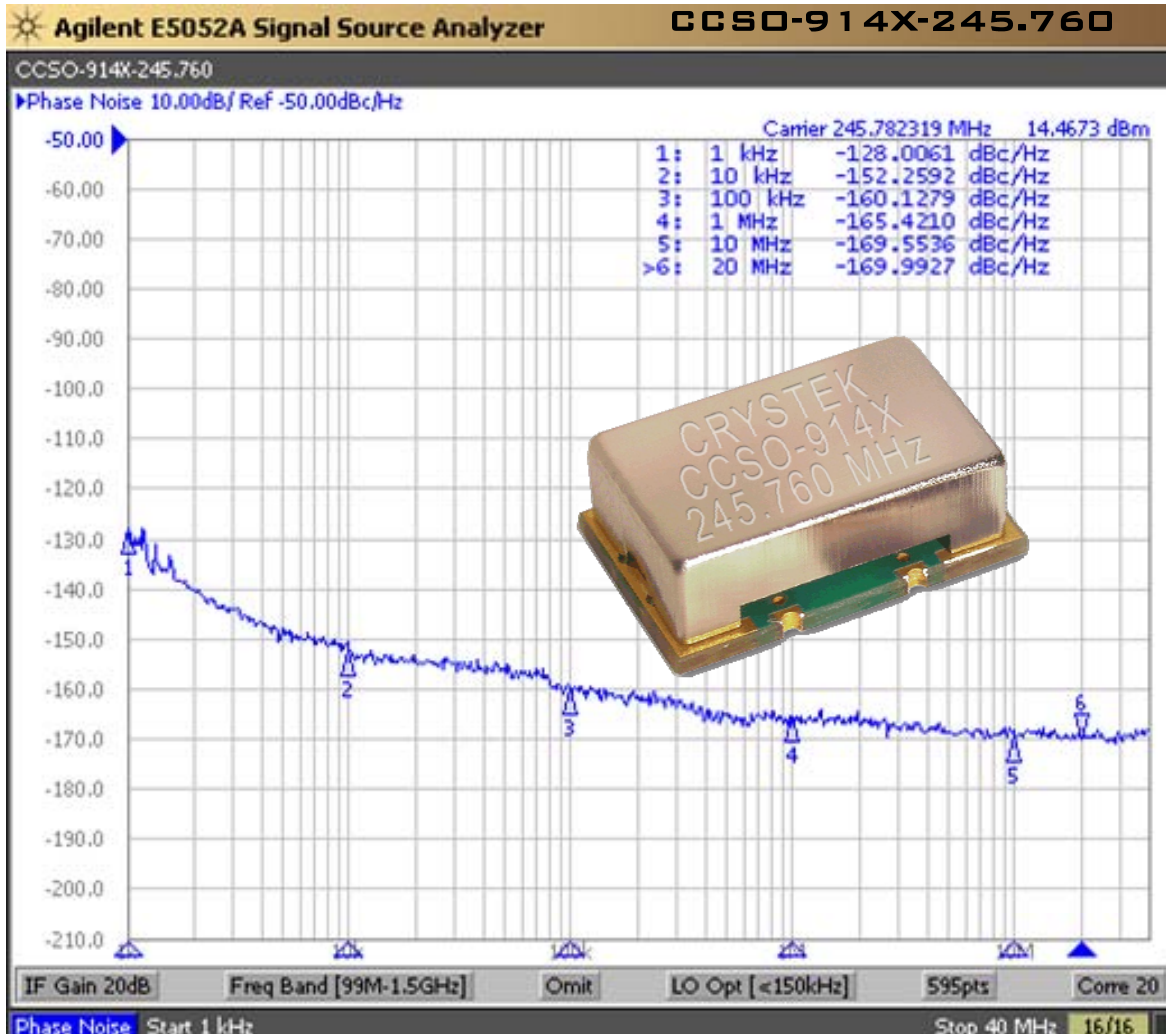

Model CCSO-914X-245.760 is a 245.760 MHz SAW (surface acoustic wave) Clock Oscillator (CCSO). SAW crystal technology provides low-noise and low-jitter performance with true sinewave output. Features include -150 dBc/Hz phase noise at 10kHz offset, 5V input voltage, -40°C to +85°C operating temperature, FR5 PCB and 9×14 mm SMT package. The oscillator has no sub-harmonic and the second harmonic is typically -20dBc.

Applications include:

System Clock for Network Clock Generator/Synchronizer, Clock for DDS, Test and Measurement, Avionics, Point-to-Point Radios, and Multi-point Radios.

Rev: B
Date: 04-Sep-2015
Page 1 of 3

CCSO-914X-245.760
True SineWave
SAW Based Clock Oscillator
9×14mm SMD
5 Volt



Frequency: 245.760 MHz
Temperature Range: -40°C to +85°C
Storage: -45°C to 90°C
Input Voltage: 5.0V ± 0.25V

Frequency vs Temperature: ±150ppm Typical
Input Current: 25mA Typical, 35mA Max
Output: True SineWave
Output Power: +8dBm Min into 50 Ω Load
Start-Up Time: 2mSec Typical, 10mSec Max
2nd Harmonic: -20dBc Typical, -15dBc Max
Sub-Harmonics: None



Jitter:
SONET OC-48(12kHz~80MHz) 17fS RMS Typical

Phase Noise Typical:

1kHz	-120 dBc/Hz
10kHz	-150 dBc/Hz
100kHz	-160 dBc/Hz
1MHz	-165 dBc/Hz
10MHz	-170 dBc/Hz

G-sensitivity: 0.9×10⁻⁹ per g

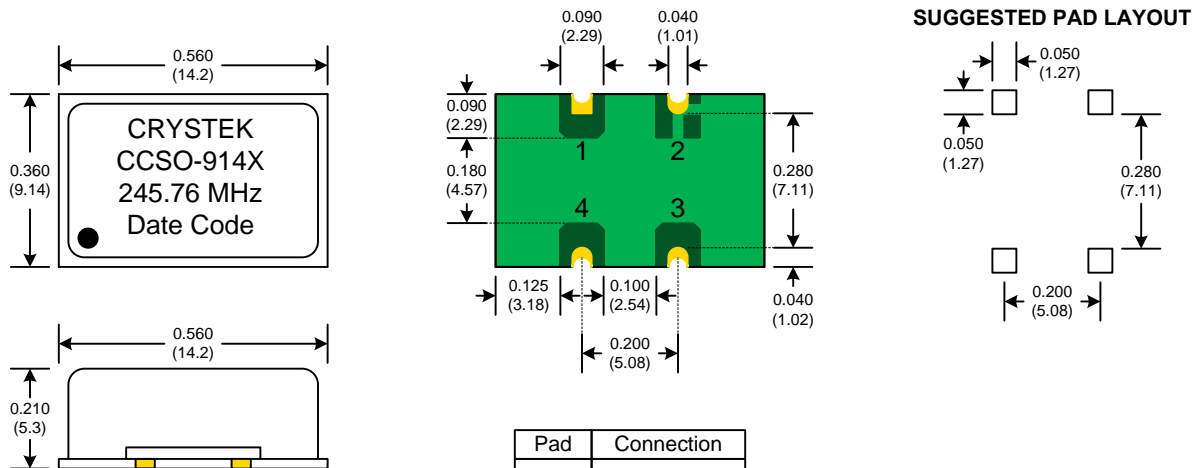

Pad	Connection
1	N/C
2	GND
3	Output
4	Vdd

Rev: B
Date: 04-Sep-2015
Page 2 of 3

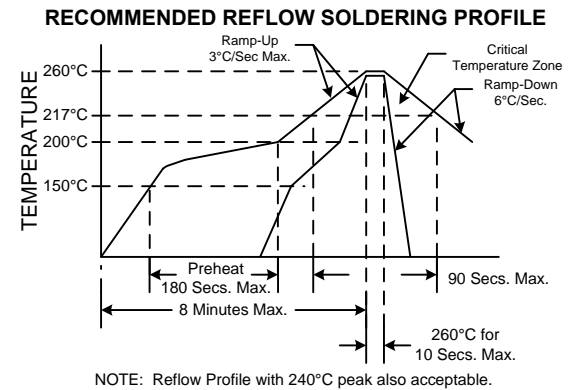
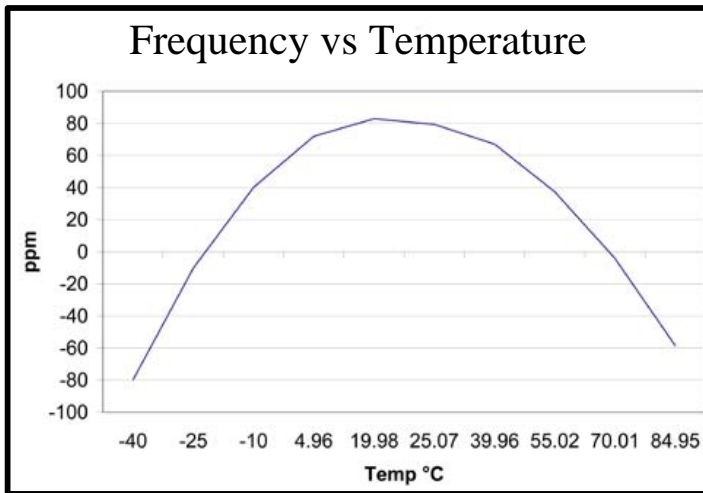
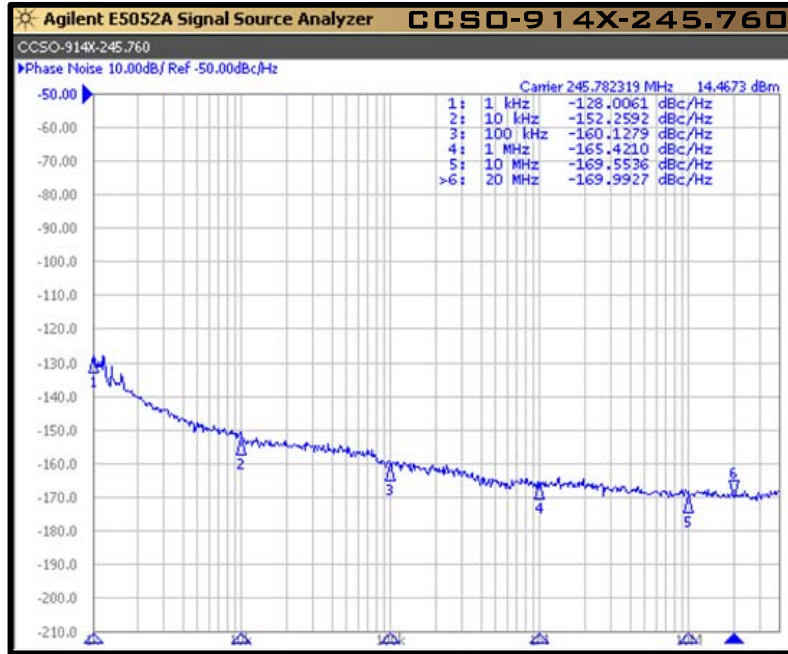

Parameter	Conditions
Mechanical Shock	MIL-STD-883, Method 2002, Condition B
Mechanical Vibration	MIL-STD-883, Method 2007, Condition A
Solderability	MIL-STD-883, Method 2003
Solvent Resistance	MIL-STD-202, Method 215
Resistance to Soldering Heat	MIL-STD-202, Method 210, Condition I or J
Thermal Shock	MIL-STD-883, Method 1011, Condition A
Moisture Resistance	MIL-STD-883, Method 1004

Rev: B
Date: 04-Sep-2015
Page 3 of 3