

**SURFACE MOUNT SCHOTTKY BARRIER RECTIFIER**

**VOLTAGE 100 Volts CURRENT 8.0 Amperes**

**FEATURES**

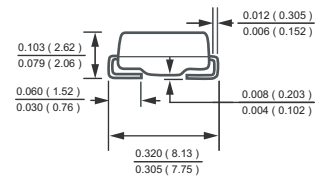
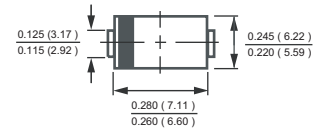
- \* Ideal for surface mounted applications
- \* Low leakage current
- \* Metallurgically bonded construction

**MECHANICAL DATA**

- \* Epoxy: Device has UL flammability classification 94V-O
- \* Mounting position: Any



**DO-214AB**



Dimensions in inches and (millimeters)

**MAXIMUM RATINGS AND ELECTRICAL CHARACTERISTICS**

Ratings at 25 °C ambient temperature unless otherwise specified.  
Single phase, half wave, 60 Hz, resistive or inductive load.  
For capacitive load, derate current by 20%.

**MAXIMUM RATINGS**\*(@ TA=25 °C unless otherwise noted)

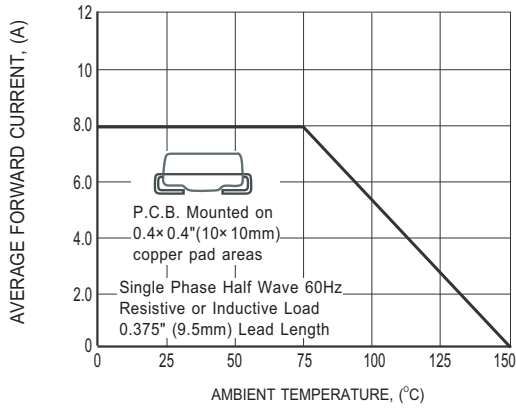
RATINGS	SYMBOL	FM8100C	UNITS
Maximum Recurrent Peak Reverse Voltage	$V_{RRM}$	100	Volts
Maximum RMS Voltage	$V_{RMS}$	70	Volts
Maximum DC Blocking Voltage	$V_{DC}$	100	Volts
Maximum Average Forward Rectified Current at Ambient Temperature	$I_O$	8.0	Amps
Peak Forward Surge Current 8.3 ms single half sine-wave superimposed on rated load (JEDEC method)	$I_{FSM}$	150	Amps
Typical Current Squared Time	$I^2T$	93.37	A <sup>2</sup> S
Typical Junction Capacitance (Note 1)	$C_J$	700	pF
Operating Temperature Range	$T_J$	-55 to + 150	°C
Storage Temperature Range	$T_{STG}$	-55 to + 150	°C

**ELECTRICAL CHARACTERISTICS**(@TA=25 °C unless otherwise noted)

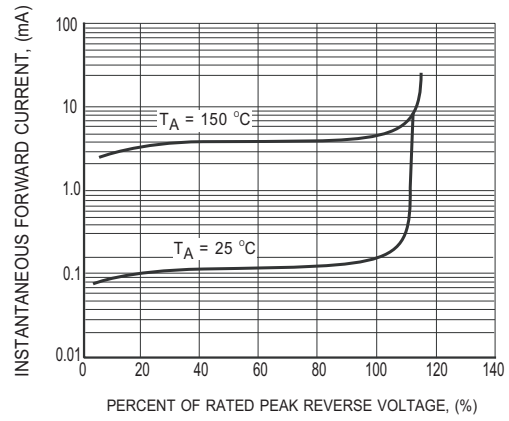
CHARACTERISTICS	SYMBOL	FM8100C	UNITS
Maximum Instantaneous Forward Voltage at 8.0A DC	$V_F$	.80	Volts
Maximum Average Reverse Current at Rated DC Blocking Voltage	@ $T_A = 25^\circ\text{C}$	0.2	mA
	@ $T_A = 150^\circ\text{C}$	5	mA

NOTES : 1. Measured at 1 MHz and applied reverse voltage of 4.0 volts.  
2. \* ROHS compliant\*.

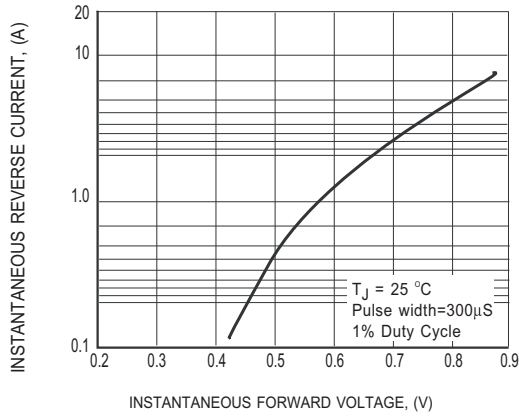
# RATING AND CHARACTERISTICS CURVES ( FM8100C )



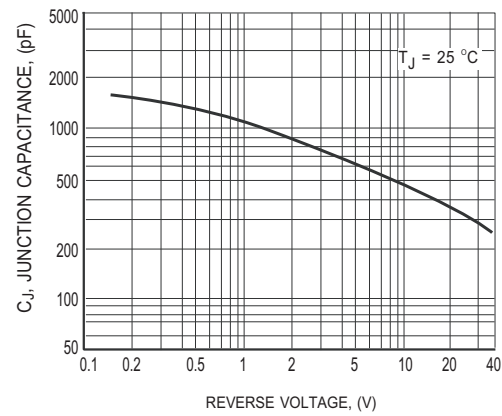
**FIG.1 TYPICAL FORWARD CURRENT DERATING CURVE**



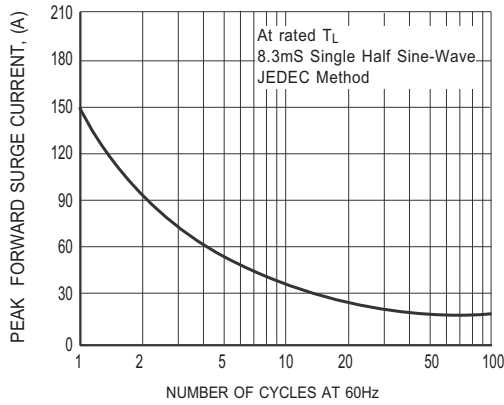
**FIG.2 MAXIMUM REVERSE CHARACTERISTICS**



**FIG.3 MAXIMUM INSTANTANEOUS FORWARD CHARACTERISTICS**

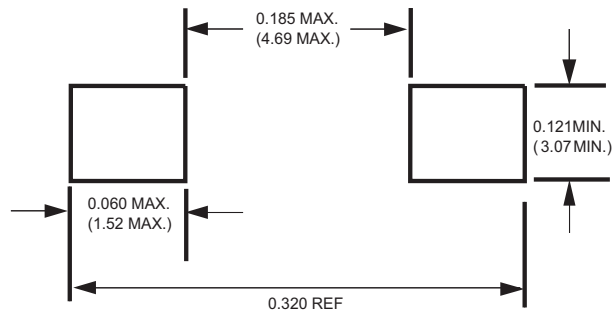


**FIG.4 TYPICAL JUNCTION CAPACITANCE**



**FIG.5 MAXIMUM NON-REPETITIVE FORWARD SURGE CURRENT**

## Mounting Pad Layout



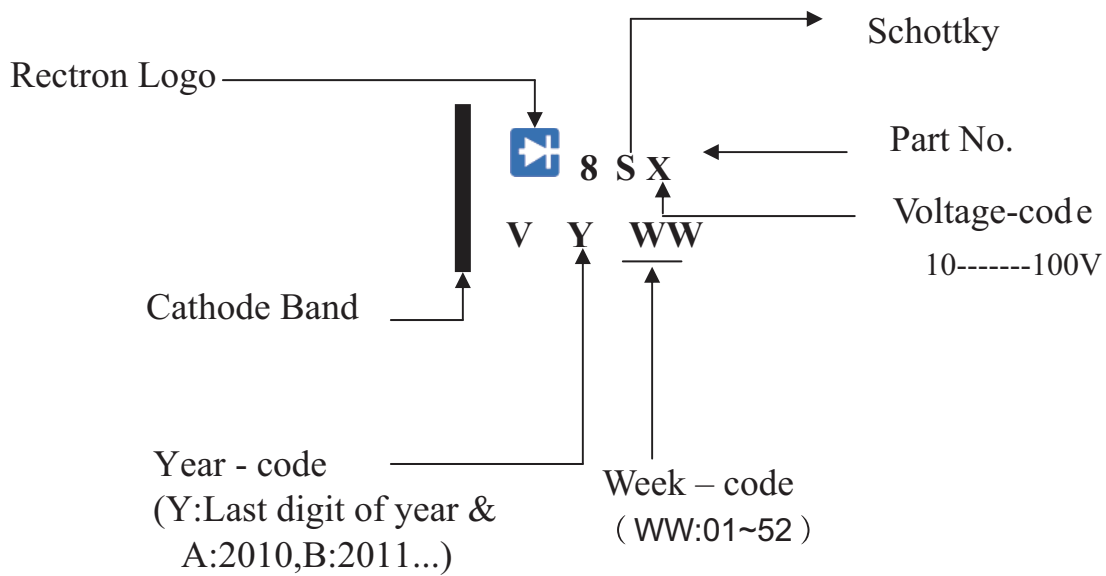
Dimensions in inches and (millimeters)

## PACKAGING OF DIODE AND BRIDGE RECTIFIERS

### REEL PACK

PACKAGE	PACKING CODE	EA PER REEL	EA PER INNER BOX	COMPONENT SPACE (mm)	TAPE SPACE (mm)	REEL DIA (mm)	CARTON SIZE (mm)	EA PER CARTON	GROSS WEIGHT(Kg)
SMC	-W/-T	3,000	3,000	---	---	330	360*355*360	24,000	11.50

## Marking Description



## DISCLAIMER NOTICE

Rectron Inc reserves the right to make changes without notice to any product specification herein, to make corrections, modifications, enhancements or other changes. Rectron Inc or anyone on its behalf assumes no responsibility or liability for any errors or inaccuracies. Data sheet specifications and its information contained are intended to provide a product description only. "Typical" parameters which may be included on RECTRON data sheets and/ or specifications can and do vary in different applications and actual performance may vary over time. Rectron Inc does not assume any liability arising out of the application or use of any product or circuit.

Rectron products are not designed, intended or authorized for use in medical, life-saving implant or other applications intended for life-sustaining or other related applications where a failure or malfunction of component or circuitry may directly or indirectly cause injury or threaten a life without expressed written approval of Rectron Inc. Customers using or selling Rectron components for use in such applications do so at their own risk and shall agree to fully indemnify Rectron Inc and its subsidiaries harmless against all claims, damages and expenditures.