

Rack-mounted DCS Signal Conditioners 18-RACK

RTD ALARM

Functions & Features

- Providing relay contact closures at preset input levels
- Direct input from an RTD
- Burnout protection
- Single or dual (Hi/Lo) trip
- Front-accessed screwdriver setpoint adjustments
- Enclosed relays

Typical Applications

- Annunciator
- Various alarm applications

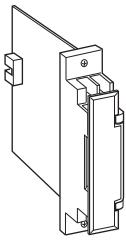

MODEL: 18AR-[1][2]-R[3]

ORDERING INFORMATION

- Code number: 18AR-[1][2]-R[3]
- Specify a code from below for each of [1] through [3].
(e.g. 18AR-45-R/BL)
- Temperature range (e.g. 0 - 250°C)
- Use Ordering Information Sheet (No. ESU-1033) to specify alarm output code 0 specifications.

[1] INPUT RTD (2- or 3-wire)

- 1:** JPt 100 (JIS'89)
(Usable range: -200 to +500°C, -328 to +932°F; min.span: 30°C, 54°F)
- 3:** Pt 100 (JIS'89)
(Usable range: -200 to +650°C, -328 to +1202°F; min.span: 30°C, 54°F)
- 4:** Pt 100 (JIS'97, IEC)
(Usable range: -200 to +650°C, -328 to +1202°F; min.span: 30°C, 54°F)
- 5:** Pt 50 Ω (JIS'81)
(Usable range: -200 to +500°C, -328 to +932°F; min.span: 60°C, 108°F)
- 6:** Ni 508.4 Ω
(Usable range: -50 to +200°C, -58 to +392°F; min.span: 20°C, 36°F)
- 0:** Specify
- Note: Consult M-System for 2-wire RTD

[2] ALARM OUTPUT

- 1:** Hi (coil energized at alarm)
- 2:** Hi (coil de-energized at alarm)

- 3:** Lo (coil energized at alarm)
- 4:** Lo (coil de-energized at alarm)
- 5:** Hi/Lo; N.O., OFF in power failure
(connector output not available)
- 6:** Hi/Lo; N.C., OFF in power failure
(connector output not available)
- 0:** Specify

POWER INPUT

DC Power

R: 24 V DC
(Operational voltage range 24 V ±10 %, ripple 10 %p-p max.)

[3] OPTIONS

Burnout

blank: Upscale burnout
/BL: Downscale burnout

GENERAL SPECIFICATIONS

Construction: Rack-mounted; terminal access via screw terminals on the front and connector on the rear; terminal cover provided

Connection

Input: M3.5 screw terminals (torque 0.8 N·m)
Alarm output: M3.5 screw terminals (torque 0.8 N·m) and connector

Power input: Supplied from connector

Screw terminal: Nickel-plated steel

Isolation: Input to output to power

Relay: Enclosed

Setpoint adjustments: Multi-turn screwdriver adjustments (front); -5 - +105 % independently

Hysteresis (deadband): Approx. 1 %

Front LEDs: Red LED turns on when the coil is energized.

INPUT SPECIFICATIONS

Maximum leadwire resistance: 20 Ω per wire (3-wire)

Sensing current: 2 mA (Pt)

OUTPUT SPECIFICATIONS

Output: Enclosed SPST and SPDT relays

Rating: 120 V AC @ 1 A (cos $\theta = 1$)

30 V DC @ 1 A (resistive load)

0.2 A maximum for the connector output

Maximum switching voltage: 120 V AC or 30 V DC

Max. switching power: 120 VA or 30 W (24 VA or 6 W for the connector output)

Minimum load: 5 V DC @ 10m A

Mechanical life: 5×10^7 cycles

• **Single Alarm**

Front terminals

	5 – 6	5 – 7
Energized	ON	OFF
De-energized (or power OFF)	OFF	ON

Rear connector

ALARM OUTPUT CODE	POWER ON		POWER OFF
	IN < SET	IN > SET	
1	OFF	ON	OFF
2	OFF	ON	ON
3	ON	OFF	OFF
4	ON	OFF	ON

• **Dual Alarm (front terminals)**

ALARM OUTPUT CODE	POWER ON				POWER OFF	
	IN < SET		IN > SET		5 – 6	7 – 8
	5 – 6	7 – 8	5 – 6	7 – 8		
5	ON	OFF	OFF	ON	OFF	OFF
6	OFF	ON	ON	OFF	OFF	OFF

Shades indicates that the relay is energized.

INSTALLATION

Current consumption: Approx. 80 mA

Operating temperature: -5 to +55°C (23 to 131°F)

Operating humidity: 30 to 90 %RH (non-condensing)

Mounting: Standard Rack 18BXx or 18KBXx

Weight: 150 g (0.33 lb)

PERFORMANCE in percentage of span

Trip point repeatability: ± 0.1 %

Temp. coefficient: ± 0.015 %/°C (± 0.008 %/°F)

Response time: ≤ 0.5 sec. (0 – 100 % at 90 % setpoint)

Burnout response: ≤ 10 sec.

Line voltage effect: ± 0.1 % over voltage range

Insulation resistance: ≥ 100 M Ω with 500 V DC

Dielectric strength: 1500 V AC @ 1 minute

(input to output or power)

500 V AC @ 1 minute (output to power)

1500 V AC @ 1 minute (input or output or power to ground)

EXTERNAL VIEW

■ SINGLE ALARM

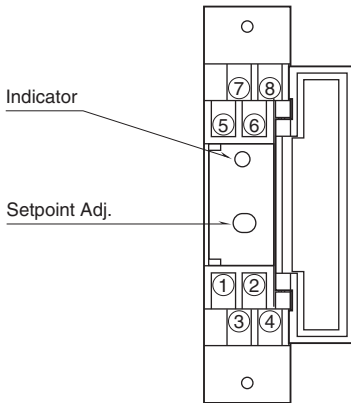

■ DUAL ALARM

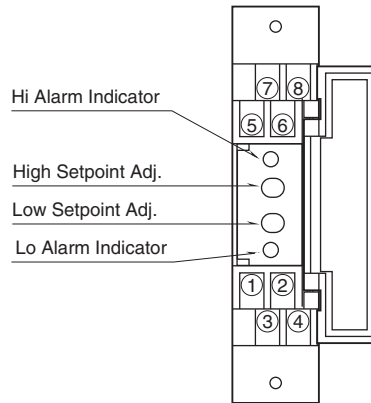

EXTERNAL DIMENSIONS unit: mm (inch)

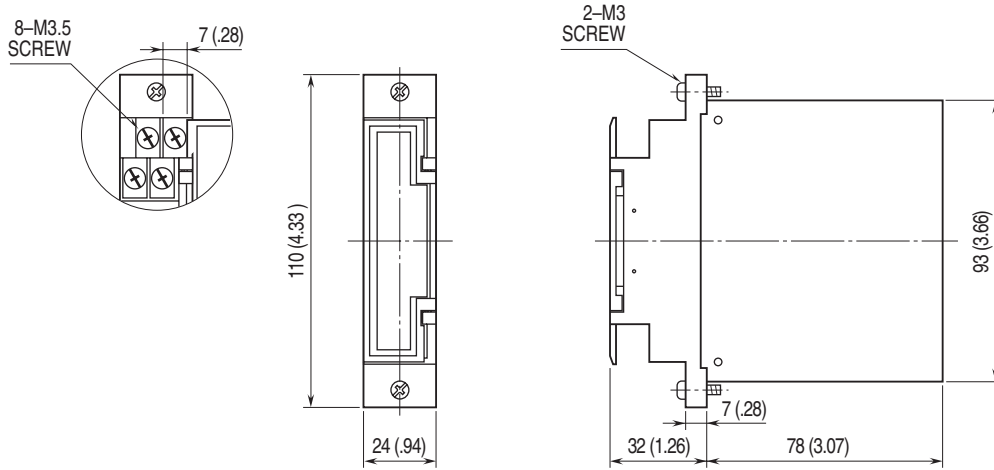

TERMINAL ASSIGNMENTS

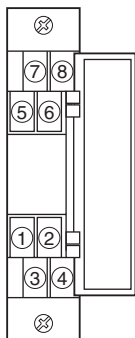

SCHEMATIC CIRCUITRY & CONNECTION DIAGRAM

■ SINGLE ALARM

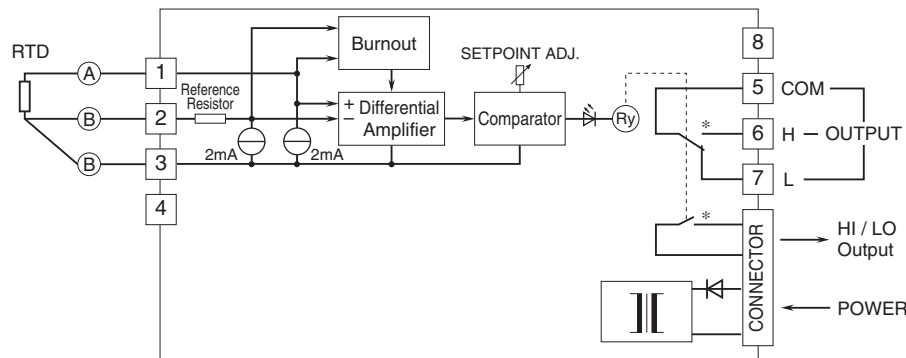

■ Relay Protection

•AC Powered

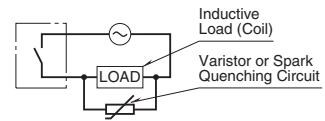

•DC Powered

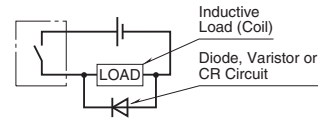

■ DUAL ALARM

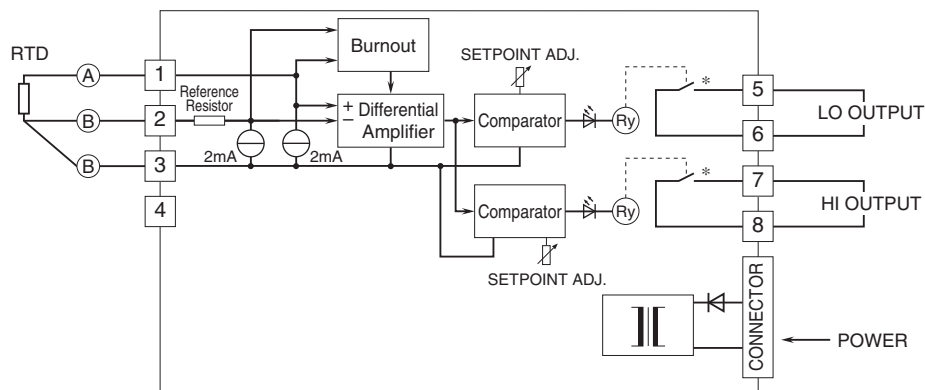

*Relay status is determined by output codes.



Specifications are subject to change without notice.