

LOW VOLTAGE DIFFERENTIAL (LVD) SCSI 9-LINE TERMINATOR

FEATURES

- First LVD only Active Terminator
- Meets SCSI SPI-2 Ultra2 (Fast-40), SPI-3 Ultra3 / Ultra160 (Fast-80) and SPI-4 (Fast-160) Ultra320 Standards
- 2.7-V to 5.25-V Operation
- Differential Failsafe Bias

DESCRIPTION

The UCC5640 is an active terminator for low voltage differential (LVD) SCSI networks. This LVD only design allows the user to reach peak bus performance while reducing system cost. The device is designed as an active Y-terminator to improve the frequency response of the LVD bus. Designed with a 1.5-pF channel capacitance, the UCC5640 allows for minimal bus loading for a maximum number of peripherals. With the UCC5640, the designer will be able to comply with the Fast-40 SPI-2, Fast-80 SPI-3 and Fast-160 SPI-4 specifications. The UCC5640 also provides a much needed system migration path for ever improving SCSI system standards. This device is available in the 24-pin TSSOP and 28-pin TSSOP for ease of layout use.

The UCC5640 is not designed for use in single ended (SE) or high voltage differential (HVD) systems.

BLOCK DIAGRAM

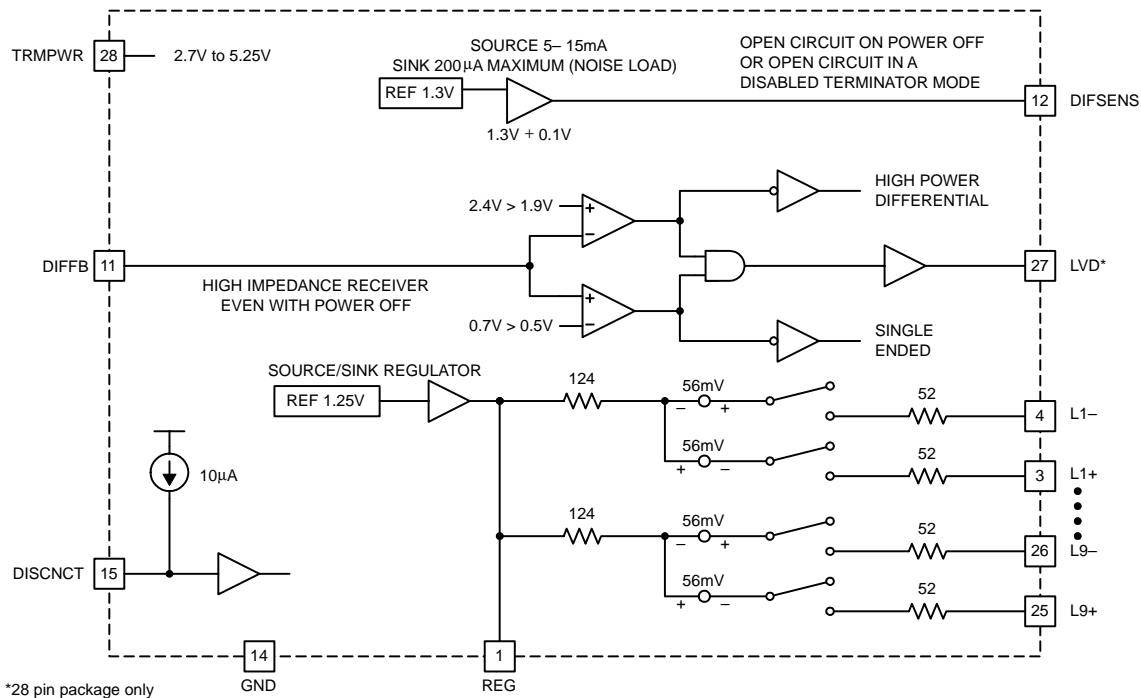

UDG-98181



These devices have limited built-in ESD protection. The leads should be shorted together or the device placed in conductive foam during storage or handling to prevent electrostatic damage to the MOS gates.

ORDERING INFORMATION

T _A	PACKAGED DEVICE†	
	TSSOP-24 (PW)	TSSOP-28 (PW)
0°C to 70°C	UCC5640PW24	UCC5640PW28

† The TSSOP packages are available taped and reeled. Add TR suffix to device type (e.g. UCC5640PW24TR) to order quantities of 2,000 devices per reel.

CONNECTION DIAGRAM

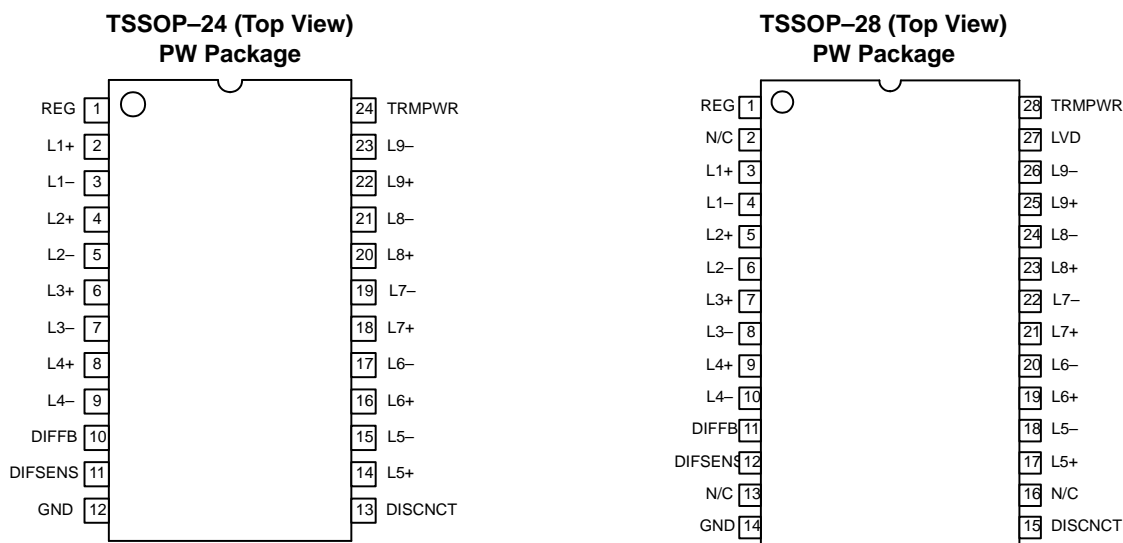

RECOMMENDED OPERATING CONDITIONS

	MIN	NOM	MAX	UNIT
TRMPWR voltage	2.7		5.25	V
Signal line voltage	0		3.6	
Disconnect input voltage	0		TRMPWR	°C

ABSOLUTE MAXIMUM RATINGS

over operating free-air temperature range unless otherwise noted†‡

	UCC5640	UNIT
TRMPWR voltage	6	V
Signal line voltage	0 to 3.6	
Package dissipation	1	W
Storage temperature, T _{stg}	-65 to 150	°C
Operating junction temperature, T _J	-55 to 150	
Lead temperature (soldering, 10 sec.)	300	

† Stresses beyond those listed under “absolute maximum ratings” may cause permanent damage to the device. These are stress ratings only, and functional operation of the device at these or any other conditions beyond those indicated under “recommended operating conditions” is not implied. Exposure to absolute-maximum-rated conditions for extended periods may affect device reliability. All voltages are with respect to GND. Currents are positive into and negative out of, the specified terminal.

‡ Currents are positive into, negative out of the specified terminal. Consult Packaging Section of Databook for thermal limitations and considerations of packages. All voltages are referenced to GND.

ELECTRICAL CHARACTERISTICST_A = 0°C to 70°C, TRMPWR = 3.3 V, T_A = T_J, (unless otherwise noted)

PARAMETER	TEST CONDITIONS	MIN	TYP	MAX	UNITS
TRMPWR Supply Current Section					
TRMPWR supply current	No load			25	mA
	Disabled terminator			400	μA
TRMPWR voltage		2.7		5.25	V
Regulator Section					
1.25V regulator	DIFSENS connected to DIFFB	1.15	1.25	1.35	V
1.25V regulator source current	DIFSENS connected to DIFFB		-100	-80	mA
1.25V regulator sink current	DIFSENS connected to DIFFB	80	100		
1.3V regulator	DIFFB connected to GND	1.2	1.3	1.4	V
1.3V regulator source current	DIFSENS to GND	-15		-5	mA
1.3V sink current	DIFSENS to 3.3 V	50		200	μA
Differential Termination Section					
Differential impedance	-2.5 mA to 4.5 mA	100	105	110	Ω
Common mode impedance	L+ connected to L-	110	150	165	
Differential bias voltage	No load, L+ or L-	100		125	mV
Common mode bias		1.15	1.25	1.35	V
Output leakage, disconnect	DISCNCT, TRMPWR = 0 V to 5.25 V, V _{LINE} = 0.2 V to 5.25 V		10	400	nA
Output capacitance	Single ended measurement to ground (1)			3	pF
Low Voltage Differential (LVD) Status Bit Section					
I _{SOURCE}	V _{LOAD} = 2.4 V		-6	-4	mA
I _{SINK}	V _{LOAD} = 0.4 V	2	5		
Disconnect & Differential Sense Input Section					
DISCNCT threshold		0.8		2	V
Input current	At 0 V and 3.3 V	-30	-10		μA
Differential sense SE to LVD threshold		0.5		0.7	V
Differential sense LVD to HPD threshold		1.9		2.4	

NOTE: (1) Ensured by design. Not production tested.

TERMINAL FUNCTIONS

TERMINAL(1)		I/O	DESCRIPTION
NAME	NO.		
DIFFB	10		Differential sense filter pin should be connected to a 4.7-μF capacitor and 50-kΩ resistor to diff sense.
DIFSENS	11		The SCSI bus differential sense line to detect what type of devices are connected to the SCSI bus.
DISCNCT	13		Disconnect pin shuts down the terminator when it is not at the end of the bus.
GND	12	I	Ground reference for the device.
Ln-		I	Negative line in differential applications for the SCSI bus.
Ln+		I	Positive line in differential applications for the SCSI bus.
LVD		I	Indicates that the bus is in LVD mode (28-pin package only).
REG	1	I	Regulator bypass; must be connected to a 4.7-μF capacitor to ground.
TRMPWR	24	I	V _{IN} 2.7-V to 5.25-V power supply.

NOTE: (1) 24-pin package.

APPLICATION INFORMATION

All SCSI buses require a termination network at each end to function properly. Specific termination requirements differ, depending on which types of SCSI driver devices are present on the bus. The UCC5640 is a low-voltage differential only device. It senses which types of drivers are present on the bus. If it detects the presence of a single-ended or high-voltage differential driver, the UCC5640 will place itself in a high-impedance input state, effectively disconnecting the chip from the bus.

The UCC5640 senses what drivers are present on the bus by the voltage on SCSI bus control line DIFFSENS, which is monitored by the DIFFB input pin. The DIFSENS output pin on the UCC5640 attempts to drive a DIFFSENS control line to 1.3 V. If only LVD devices are present, the DIFFSENS line will be successfully driven to that voltage. If HVD drivers are present, they will pull the DIFFSENS line high. If any single-ended drivers are present, they pull the DIFSENS line to ground (even if HVD drivers are also present on the bus). If the voltage on the DIFFB is below 0.5 V or above 2.4 V, the UCC5640 enters the high-impedance SE/HVD state. If it is between 0.7 V and 1.9 V, the UCC5640 enters the LVD mode. These thresholds accommodate differences in ground potential that can occur between the ends of long bus lines.

Three UCC5640 devices are required at each end of the SCSI bus to terminate 27 lines (18 data, 9 control). Every UCC5640 contains a DIFSENS driver, but only one should be used to drive the line at each end. The DIFSENS pin on the other devices should be left unconnected.

On power up, the voltage on the TRMPWR pin rising above 2.7 V, the UCC5640 assumes the SE/HVD mode.

The DIFFB inputs on all three chips at each end of the bus should be connected together. Properly filtered, noise on DIFFB will not cause a false mode change. There should be a shared 50-Hz noise filter implemented on DIFFB at each end of the bus as close as possible to the DIFFB pins. This is implemented with a 50-k Ω resistor between the DIFFB and DIFSENS pins, and a 4.7- μ F capacitor from DIFFB to ground. See Figure 1, the typical application diagram on page 6.

In LVD mode, the regulated voltage is switched to 1.25 V and a resistor network is presented to each line pair that provides common-mode impedance of 150 Ω and differential impedance of 105 Ω . The lines in each differential pair are biased so that when not driven, Line(n)+ and Line(n)- are driven 56 mV below and above the common-mode bias voltage of 1.25 V respectively.

In SE/HVD mode, all the terminating resistors are switched off the bus. The 1.25 V and 1.3 V (DIFSENS) regulators are left on.

When the disconnect input (DISCNCT) is active (high), the terminating resistors are switched off the bus and both voltage regulators are turned off to save power. The mode change filter/delay function is still active and the LVD pin in the 28-pin package continues to indicate the correct bus mode.

APPLICATION INFORMATION

The UCC5640 operates down to a TRMPWR voltage of 2.7 V. This accommodates a 3.3-V system with allowance for supply tolerance of +10%, a unidirectional fusing device and cable drop. The UCC3912 or UCC3918 is recommended on a 3.3-V systems and the UCC3916 is recommended on 5-V systems in place of a fuse and diode implementation, as its lower voltage drop provides additional voltage margin for the system.

Layout is important in all SCSI implementations and critical in SPI-3 and SPI-4 systems, which have stringent requirements on both the absolute value of capacitance on differential signal lines and the balancing of capacitance between paired lines and from pair-to-pair.

Feedthroughs, through-hole connections, and etch lengths need to be carefully balanced. Standard multilayer power and ground plane spacing adds about 1 pF to each plane. Each feed-through will add 2.5 pF to 3.5 pF. Enlarging the clearance holes on both power and ground planes reduces capacitance. Opening up the power and ground planes under a through-hole connector reduces added capacitance in those applications. Capacitance is also affected by components in close proximity on both sides of the board.

Table 1. Maximum Capacitance

SCSI CLASS	TRACE TO GND: REQ, ACK, DATA, PARITY, P_CRCA	TRACE TO TRACE: REQ, ACK, DATA, PARITY, P_CRCAALS	TRACE TO GND: OTHER SIGNALS	TRACE TO TRACE: OTHER SIGNALS
Ultra1	25 pF	N/A	25 pF	N/A
Ultra2	20 pF	10 pF	25 pF	13 pF
Ultra3/Ultra160	15 pF	8 pF	25 pF	13 pF
Ultra320	13 pF	6.5 pF	21 pF (est.)	10 pF (est.)

TI terminators are designed with very tightly controlled capacitance on their signal lines. Between the positive and negative lines in a differential pair the difference is typically no more than 0.1 pF, and only 0.3 pF between pairs.

Multilayer boards need to adhere to the 120-Ω impedance standard, including the connector and feedthroughs. Bus traces are normally run on the outer layers of the board with 4-mil etch and 4-mil spacing between the two lines in each differential pair, and a minimum of 8-mil spacing to adjacent pairs to minimize crosstalk. Microstrip technology is too low in impedance and should not be used, they are designed for 50-Ω rather than 120-Ω differential systems.

Decoupling capacitors should be installed as close as possible to the following input pins of the UCC5640:

1. TRMPWR: 4.7-μF capacitor to ground, 0.01-μF capacitor to ground (high frequency, low ESR)
2. REG: 4.7-μF capacitor to ground, 0.01-μF capacitor to ground (high frequency, low ESR)

APPLICATION INFORMATION

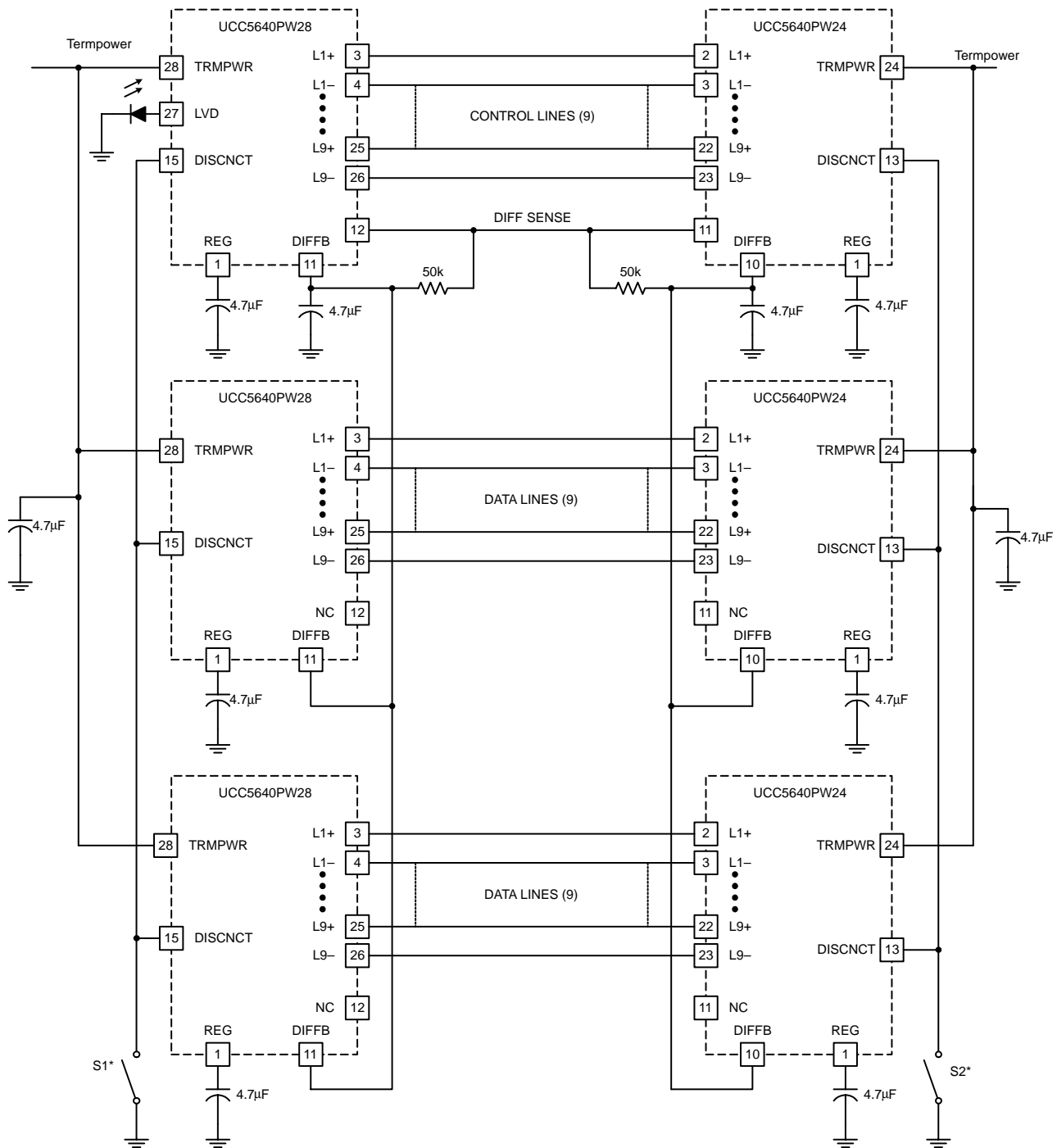

* CLOSE S1 AND S2 TO CONNECT TERMINATORS

UDG-98100

Figure 1. Application Diagram

MECHANICAL DATA

PWP (R-PDSO-G**)

PowerPAD™ PLASTIC SMALL-OUTLINE

20 PINS SHOWN

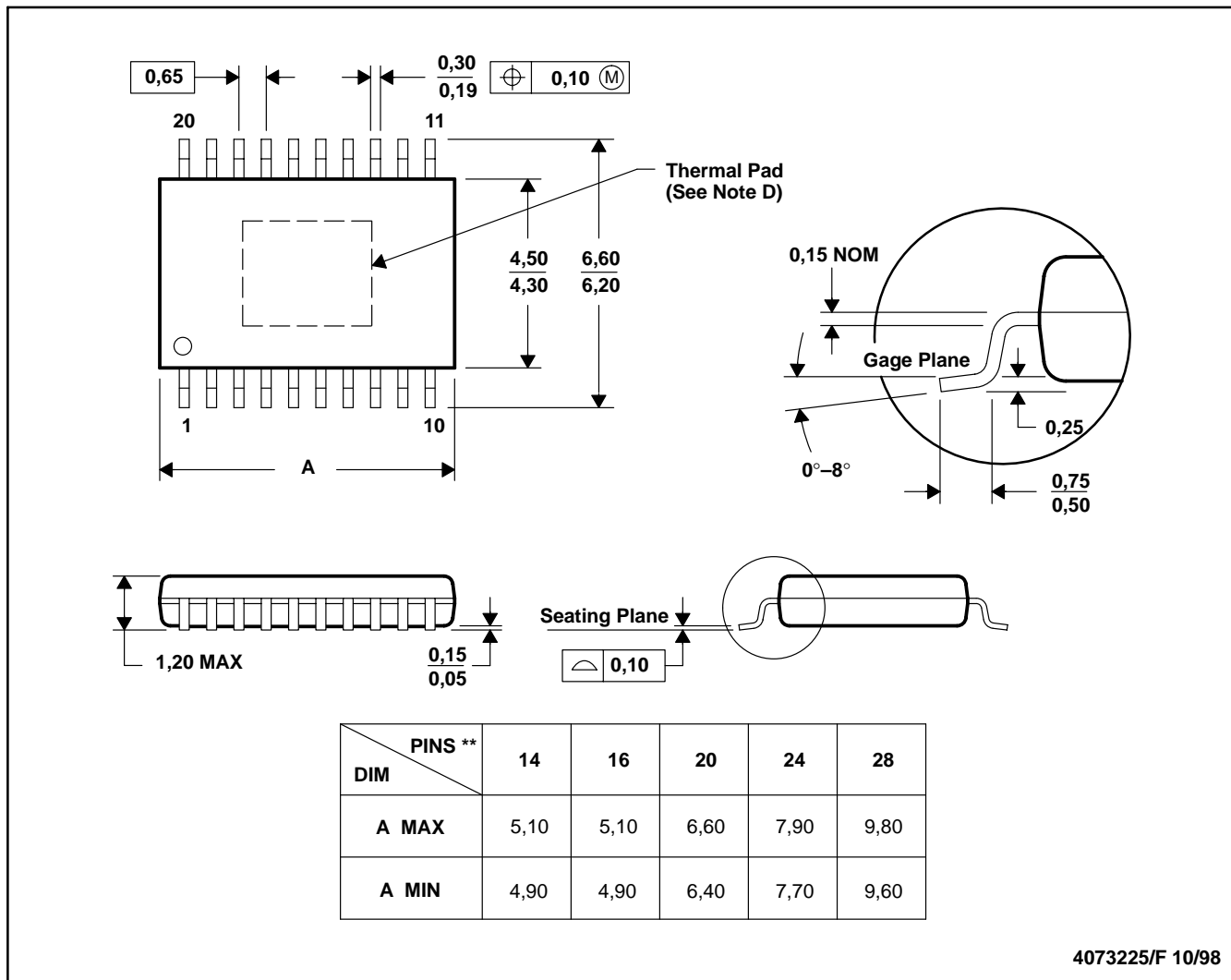

- NOTES:
- A. All linear dimensions are in millimeters.
 - B. This drawing is subject to change without notice.
 - C. Body dimensions do not include mold flash or protrusions.
 - D. The package thermal performance may be enhanced by bonding the thermal pad to an external thermal plane. This pad is electrically and thermally connected to the backside of the die and possibly selected leads.
 - E. Falls within JEDEC MO-153

PACKAGING INFORMATION

Orderable Device	Status ⁽¹⁾	Package Type	Package Drawing	Pins	Package Qty	Eco Plan ⁽²⁾	Lead/Ball Finish	MSL Peak Temp ⁽³⁾
UCC5640PW24	ACTIVE	TSSOP	PW	24	60	None	CU SNPB	Level-2-220C-1 YEAR
UCC5640PW24TR	ACTIVE	TSSOP	PW	24	2000	None	CU SNPB	Level-2-220C-1 YEAR
UCC5640PW28	ACTIVE	TSSOP	PW	28	50	None	CU SNPB	Level-2-220C-1 YEAR
UCC5640PW28TR	ACTIVE	TSSOP	PW	28	2000	None	CU SNPB	Level-2-220C-1 YEAR

⁽¹⁾ The marketing status values are defined as follows:

ACTIVE: Product device recommended for new designs.

LIFEBUY: TI has announced that the device will be discontinued, and a lifetime-buy period is in effect.

NRND: Not recommended for new designs. Device is in production to support existing customers, but TI does not recommend using this part in a new design.

PREVIEW: Device has been announced but is not in production. Samples may or may not be available.

OBSOLETE: TI has discontinued the production of the device.

⁽²⁾ Eco Plan - May not be currently available - please check <http://www.ti.com/productcontent> for the latest availability information and additional product content details.

None: Not yet available Lead (Pb-Free).

Pb-Free (RoHS): TI's terms "Lead-Free" or "Pb-Free" mean semiconductor products that are compatible with the current RoHS requirements for all 6 substances, including the requirement that lead not exceed 0.1% by weight in homogeneous materials. Where designed to be soldered at high temperatures, TI Pb-Free products are suitable for use in specified lead-free processes.

Green (RoHS & no Sb/Br): TI defines "Green" to mean "Pb-Free" and in addition, uses package materials that do not contain halogens, including bromine (Br) or antimony (Sb) above 0.1% of total product weight.

⁽³⁾ MSL, Peak Temp. -- The Moisture Sensitivity Level rating according to the JEDEC industry standard classifications, and peak solder temperature.

Important Information and Disclaimer:The information provided on this page represents TI's knowledge and belief as of the date that it is provided. TI bases its knowledge and belief on information provided by third parties, and makes no representation or warranty as to the accuracy of such information. Efforts are underway to better integrate information from third parties. TI has taken and continues to take reasonable steps to provide representative and accurate information but may not have conducted destructive testing or chemical analysis on incoming materials and chemicals. TI and TI suppliers consider certain information to be proprietary, and thus CAS numbers and other limited information may not be available for release.

In no event shall TI's liability arising out of such information exceed the total purchase price of the TI part(s) at issue in this document sold by TI to Customer on an annual basis.

PW (R-PDSO-G**)

PLASTIC SMALL-OUTLINE PACKAGE

14 PINS SHOWN



4040064/F 01/97

- NOTES: A. All linear dimensions are in millimeters.
 B. This drawing is subject to change without notice.
 C. Body dimensions do not include mold flash or protrusion not to exceed 0,15.
 D. Falls within JEDEC MO-153

IMPORTANT NOTICE

Texas Instruments Incorporated and its subsidiaries (TI) reserve the right to make corrections, modifications, enhancements, improvements, and other changes to its products and services at any time and to discontinue any product or service without notice. Customers should obtain the latest relevant information before placing orders and should verify that such information is current and complete. All products are sold subject to TI's terms and conditions of sale supplied at the time of order acknowledgment.

TI warrants performance of its hardware products to the specifications applicable at the time of sale in accordance with TI's standard warranty. Testing and other quality control techniques are used to the extent TI deems necessary to support this warranty. Except where mandated by government requirements, testing of all parameters of each product is not necessarily performed.

TI assumes no liability for applications assistance or customer product design. Customers are responsible for their products and applications using TI components. To minimize the risks associated with customer products and applications, customers should provide adequate design and operating safeguards.

TI does not warrant or represent that any license, either express or implied, is granted under any TI patent right, copyright, mask work right, or other TI intellectual property right relating to any combination, machine, or process in which TI products or services are used. Information published by TI regarding third-party products or services does not constitute a license from TI to use such products or services or a warranty or endorsement thereof. Use of such information may require a license from a third party under the patents or other intellectual property of the third party, or a license from TI under the patents or other intellectual property of TI.

Reproduction of information in TI data books or data sheets is permissible only if reproduction is without alteration and is accompanied by all associated warranties, conditions, limitations, and notices. Reproduction of this information with alteration is an unfair and deceptive business practice. TI is not responsible or liable for such altered documentation.

Resale of TI products or services with statements different from or beyond the parameters stated by TI for that product or service voids all express and any implied warranties for the associated TI product or service and is an unfair and deceptive business practice. TI is not responsible or liable for any such statements.

Following are URLs where you can obtain information on other Texas Instruments products and application solutions:

Products		Applications	
Amplifiers	amplifier.ti.com	Audio	www.ti.com/audio
Data Converters	dataconverter.ti.com	Automotive	www.ti.com/automotive
DSP	dsp.ti.com	Broadband	www.ti.com/broadband
Interface	interface.ti.com	Digital Control	www.ti.com/digitalcontrol
Logic	logic.ti.com	Military	www.ti.com/military
Power Mgmt	power.ti.com	Optical Networking	www.ti.com/opticalnetwork
Microcontrollers	microcontroller.ti.com	Security	www.ti.com/security
		Telephony	www.ti.com/telephony
		Video & Imaging	www.ti.com/video
		Wireless	www.ti.com/wireless

Mailing Address: Texas Instruments
Post Office Box 655303 Dallas, Texas 75265