

Rev	AWO #	Description	Date	Appr
-		RELEASED	6/16/11	

APPROVED: _____
 DATE: _____ TITLE: _____

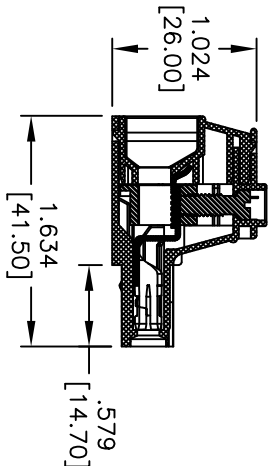
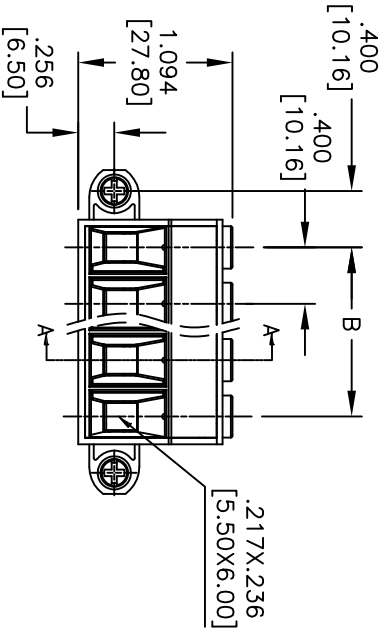
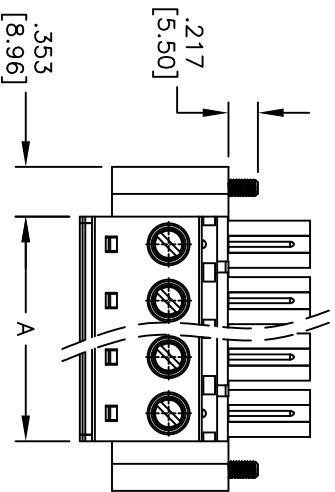

SECTION A-A

Poles: 2 thru 12
 A = .400 [10.16] X No. of Spaces + .394 [10.00]
 B = .400 [10.16] X No. of Spaces

SPECIFICATIONS:

- Material:**
 Insulator: Thermoplastic, rated UL 94V-0
 Insulator color: Green
 Clamp: Brass, Nickel plated
 Screw: M4.5, Steel, Zn plated
 Wire guard: Stainless Steel
 Flange screw: M3, Steel, Zn plated
 Contact: Copper Alloy, Tin plated.
- Electrical:**
 Operation voltage: 300 VAC
 Current rating: 55 Amps
- Mechanical:**
 Wire strip length: 13-14mm
 Torque (Lb-In): 10.4
 Withstanding Voltage: 1.6KV
- Environmental:**
 Operating temperature: -40°C to +115°C
 Lead free, RoHS compliant.
 Recommended soldering temp: 235°C for 5 sec.



UNLESS OTHERWISE SPECIFIED	
ALL DIMENSIONS ARE MM [INCHES]	
TOLERANCES: EXCEPT AS NOTED	
INCHES	HOLDS
.X ± .10	± .10
.XX ± .020	± .015
.XXX ± .015	± .010
APPROVALS	DATE
DRAWN	DY
CHECKED	
APPROVED	

ADAM TECH
 909 Rahway Avenue, Union, NJ 07083
 Phone: 908-687-5000 Fax: 908-687-5710

TITLE: EURO BLOCK, .400 [10.16] PITCH

SIZE	PART NO.	REV.
X	EB45-XX-J-E	-
REF: S00007T	SCALE: NTS	SHEET 1 OF 1